

EPSON®
DFX-8000

User's Manual

FCC COMPLIANCE STATEMENT FOR AMERICAN USERS

This **equipment** has been tested and found to **comply with the** limits for a class **B** digital **device**, pursuant to Part **15** of the **FCC Rules**. **These limits are** designed to provide reasonable protection against harmful interference in a residential installation. This equipment generates, uses and can radiate radio frequency energy and, if not installed and used in accordance with the instructions, may **cause harmful interference to radio communications**. However, there is no guarantee that **interference will not occur in a particular installation**. If this equipment does cause **harmful interference to radio or television reception, which can** be determined by **turning** the equipment off and on, the user is encouraged to try to correct the interference by one or more of the following measures:

- Reorient or relocate the receiving antenna.
- Increase the separation between the **equipment** and receiver.
- Connect the **equipment** into an outlet on a circuit different from that to which the receiver is connected.
- Consult the dealer or an experienced radio/TV technician for help.

WARNING

The connection of a non-shielded printer interface cable to this printer will invalidate the FCC Certification of this device and may cause **interference** levels which exceed the **limits established** by the **FCC** for this **equipment**. If this **equipment** has more than one interface connector, do not leave cables connected to unused interfaces.

Seiko Epson Corporation shall not be liable against any damages or problems **arising** from the use of any options or any consumable products other than those designated as **Original** Epson Products or Epson Approved Products by Seiko Epson Corporation.

All rights reserved. No part of this publication may be reproduced, stored in a retrieval system, or transmitted, in any form **or** by any means, mechanical, photocopying, recording, or otherwise, without the prior written **permission** of Epson America, Inc. No patent liability is assumed with respect to the use of the information contained herein. While every precaution has been taken in the preparation of this book, Epson America, Inc. assumes no responsibility for errors or omissions. Neither is any liability assumed for damages **resulting** from the use of the information contained herein.

FOR CANADIAN USERS

This digital apparatus does not exceed the Class **B** limits for radio noise emissions from digital apparatus as set out in the radio interference regulations of the Canadian Department of Communications.

Le présent appareil numérique n'émet pas de bruits radioélectriques dépassant les limites applicables aux appareils numériques de Classe B prescrites dans le règlement sur le brouillage radioélectrique édicté par le Ministère des Communications du Canada.

Epson and Epson **ESC/P** are registered trademarks of Seiko Epson Corporation.
IBM is a registered trademark of **International** Business Machines Corporation.

Graphics created with **UniPaint** by Unison World Inc. and Epson **3D-Graph**.

Copyright © **1989** by Epson America Inc.
Torrance, California

IMPORTANT SAFETY INSTRUCTIONS

1. **Read all** of these instructions and save them for later reference.
2. Follow all **warnings** and instructions marked on the product.
3. **Unplug** this product from the wall outlet before cleaning. Do not use **liquid** cleaners or aerosol cleaners. Use a damp cloth for cleaning.
4. Do not use this product near water.
5. Do not **place this** product on an unstable cart, stand, or table. The product may **fall**, causing serious damage to the product.
6. Slots and openings in the cabinet and the back or bottom are **provided** for ventilation; to ensure reliable operation of the product and to protect it from overheating, these openings must not be blocked or covered. The openings should never be blocked by placing the product **on a** bed, sofa, rug, or other similar surface. This product should never be placed near or over a radiator or heat register. **This product should** not be placed in a **built-in installation** unless proper ventilation is provided.
7. This product should be operated from the type of power source indicated on the marking label. If you are not sure of the type of power available, consult your dealer or local power company.
8. This product is equipped with a **3-wire** grounding-type plug, a plug having a third (grounding) prong. This plug will only fit into a grounding-type power outlet. **This** is a safety feature. **If** you are unable to insert the plug into the outlet, contact your electrician to replace your obsolete outlet. Do not defeat the purpose of the grounding-type **plug**.
9. Do not locate this product where the cord will be walked on.

10. If an **extension cord** is used **with this** product, make sure that the total of the ampere ratings on the products **plugged** into the extension cord does not **exceed the** extension cord ampere rating. Also, make sure that the total **of** all products plugged into the wall outlet does not exceed **15** amperes.
11. Never **push** objects of any kind into this product through cabinet slots as they may touch dangerous voltage points or short out parts that could result in a risk of fire or electric shock. Never spill liquid of any kind on the product.
12. Except as specifically explained in the User's Manual, do not attempt to service this product yourself. Opening or removing those covers that are marked 'Do Not **Remove**' may expose you to dangerous voltage points or other risks. Refer all servicing **in** those compartments to service personnel.
13. Unplug this product from the wall outlet and refer servicing to qualified service personnel under the following conditions:
 - A. When the power cord or **plug** is damaged or frayed.
 - B. If liquid has been spilled into the product.
 - C. If the product has been exposed to rain or water.
 - D. If the **product does** not operate normally when the operating instructions are followed. Adjust only those controls that are covered by the operating instructions since improper adjustment of other controls may result in damage and will often require extensive work by a qualified technician to restore the product to normal operation.
 - E. If the product has been dropped or the **cabinet** has been damaged.
 - F. If the product exhibits a distinct change in performance, indicating a need for service.

Contents

About This Manual	1
Introduction	3
Chapter 1 Setting Up the Printer	1-1
Unpacking the Printer	1-2
Choosing a Place for the Printer	1-7
Assembling the Printer	1-9
Testing the Printer	1-13
Connecting the Printer to Your Computer	1-26
Setting Up Your Application Software	1-36
Chapter 2 Paper Handling	2-1
Using the Two-Tractor System	2-2
Switching between Front and Rear Tractors	2-20
Changing the Paper	2-24
Printing on Special Paper	2-29
Chapter 3 Using the Printer	3-1
Operating the Control Panel	3-2
Setting the DIP Switches	3-7
Page Length	3-17
Skip Over Perforation	3-18
Using the Paper Memory Feature	3-20
Adjusting the Top of Form Position	3-33
Adjusting the Printing Position	3-37
Using Short Tear-Off	3-40
Selecting Typestyles	3-43

Selecting an International Character Set	3-47
Choosing a Character Table	3-49
Data Dump Mode	3-51
Chapter 4 Software and Graphics	4-1
Enhancing Your Printing	4-2
Graphics	4-10
User-defined Characters	4-22
Chapter 5 Using the Printer Options	5-1
Pull Tractor	5-2
Paper Cutter	5-19
Interface Boards	5-32
Chapter 6 Maintenance	6-1
Cleaning the Printer	6-2
Replacing the Ribbon	6-4
Transporting the Printer	6-9
Chapter 7 Troubleshooting	7-1
Problems and Solutions	7-2
Power Supply	7-3
Printing	7-4
Paper Handling	7-13
Options	7-18
Chapter 8 Technical Specifications	8-1
Printer Specifications	8-2
Interface Specifications	8-11
Initialization	8-17

Chapter 9 Command Summary	9-1
Using the Command Summary	9-2
Commands in Numerical Order	9-5
Epson ESC/P Commands Arranged by Topic	9-9
IBM Emulation Mode Commands Arranged by Topic..	9-41
Appendix	A-1
Proportional Width Table	A-2
Character Tables	A-6
Glossary	GL-1
Index	IN-1

About This Manual

This user's manual provides fully-illustrated, step-by-step instructions for setting up and operating the Epson DFX-8000 printer. It also includes information that you will need for your daily use of the printer.

- Chapter **1** shows you how to unpack, set up, test, and connect the printer. Be sure to read and follow the instructions in this chapter first. Inside the back cover of this manual **are** illustrations that identify the parts of the printer. You may want to unfold the cover and refer to these illustrations as you set up and operate the printer.
- Chapters **2** and **3** describe loading paper and using the printer. This information is necessary for the day-to-day operation of your printer.
- Chapter **4** provides information on enhancing your printing, using software commands and graphics, and creating your own user-defined characters. Chapter **9** contains a summary of printer commands.
- Chapter **7** contains troubleshooting information. If the printer does not operate properly or the printed results are not what you expect, see Chapter **7** for a list of possible problems and recommended solutions.
- Other chapters contain information on printer options, general maintenance, and specifications. You will also find an appendix with reference tables, a glossary of printer terms, and an index.
- At the back of this manual is a handy Quick Reference card that lists DIP switch settings and printer commands.

Conventions used in this manual



WARNINGS must be followed carefully to avoid damage to your printer and computer.



CAUTIONS must be followed to ensure that your printer operates correctly.

Notes **contain important** information and useful tips on the operation of your printer.

Where to Get Help

Customer support and service for Epson products are provided by a network of authorized Epson dealers and Customer Care Centers throughout the United States. Epson **America** provides product **information and support to its dealers and Customer Care Centers.**

Therefore, we ask that you contact the business where you purchased your Epson product to request assistance. If the people there do not have the answer to your question, they can obtain it through our dealer support program.

Epson is confident that this policy will provide you with the assistance you need. Call the Epson Consumer Information Center at **1-800-922-8911** for the following:

- The location of the nearest Epson dealer
- The location of the nearest Customer Care Center
- Information on Epson User Groups.

Introduction

The Epson DFX-8000 printer is an advanced dot matrix printer designed for business applications. The printer combines high performance and reliability with a wide range of **features**, including high speed printing and automatic paper handling.

Features

In addition to the high-quality printing and ease of operation you expect from Epson printers, the DFX-8000 offers the following:

- Extra-fast printing speeds of up to **1066** characters per second at **10 cpi** (**characters** per inch) or **960** characters per second at **12 cpi**.
- Two built-in push tractors (front and rear) for convenient paper handling. This dual system lets you switch between types of continuous paper quickly **and easily**. The printer remembers separate top of form positions for each tractor,
- An automatic paper back-out feature that allows you to switch between paper loaded on the front or rear tractor without removing either paper supply.
- A short tear-off feature that saves paper. When a sheet of continuous paper is torn off at the end of a printout, the printer reverse-feeds the remaining paper so that printing can begin at the top of the next sheet.
- A paper memory feature that produces high quality printing on your multi-part forms by using stored paper format and thickness information to adjust the print head.
- A width detection feature that automatically adjusts the printing to match the width of the paper loaded in the printer. This prevents the printer from printing directly on the platen, which damages the print head.

Introduction

- A micro-adjustment feature that allows you to feed the paper forward or backward to finely adjust the top of form, loading, and short tear-off positions.
- An improved control panel design that lets you select almost any feature with a single button.
- Compatibility with the **Epson ESC/P® commands used by FX-850/1050 and DFX-5000 printers.**
- An **IBM®** emulation mode that provides compatibility with application programs written specifically for IBM printers.

Options

The following **options are available for use** with your DFX-8000 printer. For detailed **information on installing and** using these options, see Chapter 5.

- **Pull Tractor (#8309)**

This option improves the handling of **heavy** multi-part forms and labels. It also enhances printing alignment on preprinted forms.

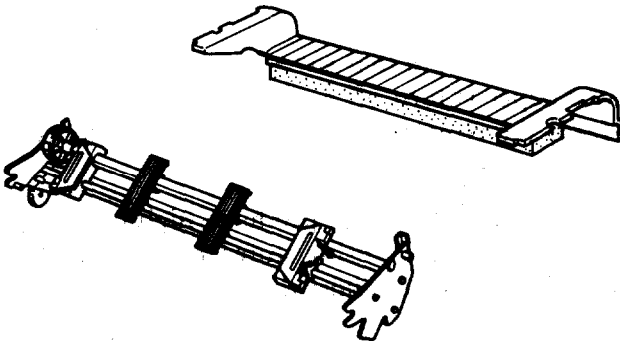

- **Paper Cutter (C815001)**

This option allows you to handle continuous paper more easily by cutting off printed documents for you.

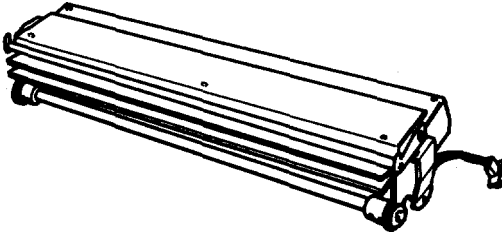

- **Interface Boards**

You can use several optional interface boards to supplement the printer's built-in parallel and serial interfaces. Chapter 5 provides guidelines for choosing the right interface and instructions for installing an interface board.

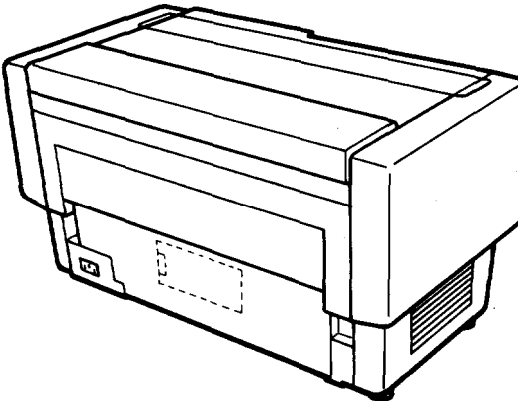

Coax and **Twinax** interface boards

Two **interface** boards (Coax and **Twinax**) let you use the **DFX-8000** as a local printer **for** an IBM mainframe or minicomputer. These boards connect directly to the printer and allow it to function as a local IBM printer without the addition of any other circuitry or components.

Chapter 1

Setting Up the Printer

Unpacking the Printer	1-2
Checking the parts	1-3
Removing the protective materials	1-4
Choosing a Place for the Printer	1-7
Assembling the Printer	1-9
Installing the ribbon cartridge	1-9
Testing the Printer	1-13
Plugging in the printer	1-13
Running the self test	1-15
Solving any self test problems	1-24
Connecting the Printer to Your Computer	1-26
The parallel interface	1-27
The serial interface	1-31
Setting Up Your Application Software	1-36

Unpacking the Printer

Because the printer weighs approximately **64 lbs. (29 kg)**, you should not lift or carry it alone. Two people should carry it by the bottom, as shown here:

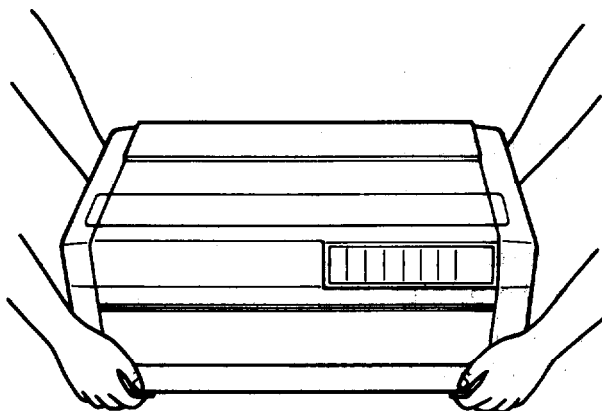

Unpacking the Printer

Checking the parts

When you unpack the printer, make sure that you **have** all the parts shown below and that none **have been damaged** during transportation.

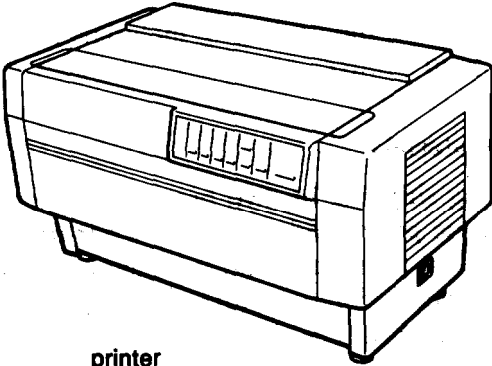

printer

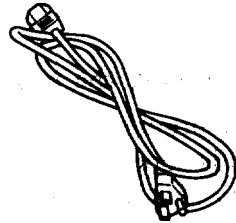

power cable

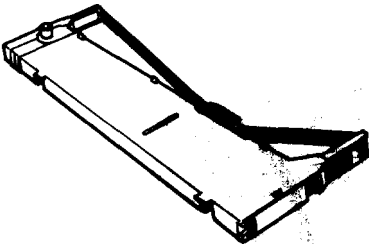

ribbon cartridge



optional connector lock nuts

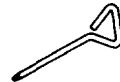

cross-head screwdriver

In some locations, the power cable may be attached to the printer.

Unpacking the Printer



WARNING: There are several different versions of the printer designed for different electrical standards. The power **supply** voltage is shown on the label on the back of the printer. If the voltage shown is not correct for your country, contact your dealer. It is not possible to adjust the printer for use with different voltages.

After you unpack the printer, save the packaging materials in case you ever need to transport your printer.

Removing the protective materials

The printer is protected during shipping by two brackets, a carriage guide support bar, and a plastic print head protector. Your printer may also be protected by several pieces of foam packaging. These protective items must be removed before you turn on the printer. After removing the protective materials **as** described below, store them with the other packaging material.

1. Open the top cover by lifting its front edge up and away from you. Remove any packing materials in the printer.

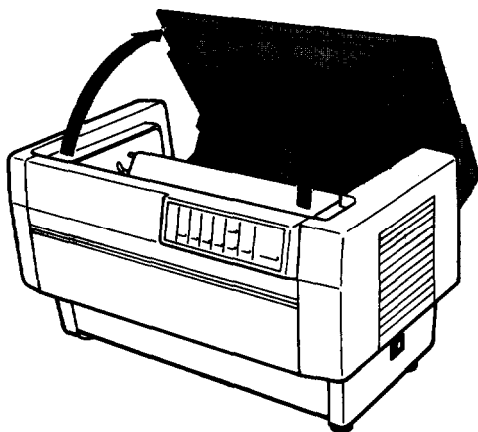

2. Use the enclosed cross-head screwdriver to remove the five screws and the two transport locking brackets from the inside of the printer.

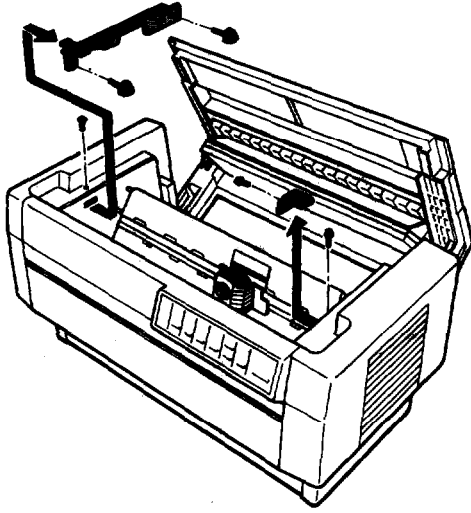

3. Remove the print head protector, as shown below. Then lift up the paper bail and remove the piece of foam packing underneath it.

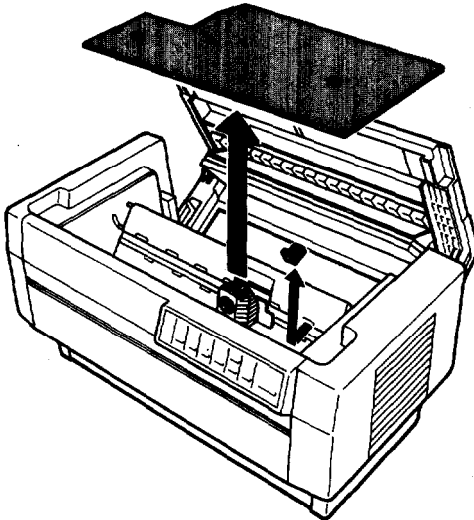

Unpacking the Printer

4. Using the enclosed cross-head screwdriver, remove the carriage guide support bar.

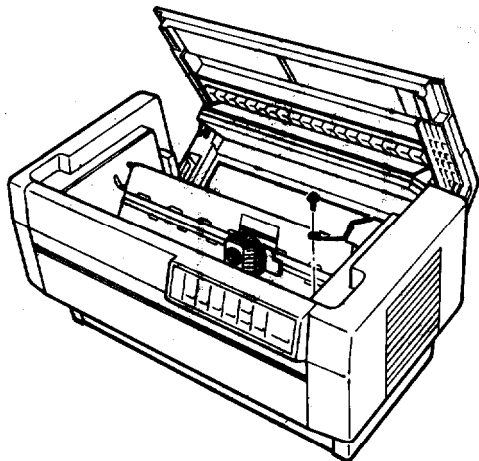

WARNING: Be sure to remove all protective materials before you turn on the printer.

Choosing a Place for the Printer

When you select a location for your printer, keep the following in mind:

- Place the printer on a flat, stable surface.
- Place the printer close enough to the computer for the printer cable to reach.
- Leave plenty of room around the printer for your front and rear stacks of continuous paper as well as your printed output.
- Use a grounded outlet; do not use an adapter plug.



WARNING: Avoid locations that are subject to direct sunlight, excessive heat, moisture, or dust.

- Avoid using electrical outlets that are controlled by wall switches or automatic timers. Accidental interruption of power can wipe out information in your computer's and your printer's memory.
- Avoid using outlets on the same circuit with large motors or electrical appliances that might cause fluctuations in line voltage.
- Keep the entire computer system away from potential sources of electromagnetic interference; such as loudspeakers or the base units of cordless telephones.

Choosing a Place for the Printer

The illustration below shows a good printer location.

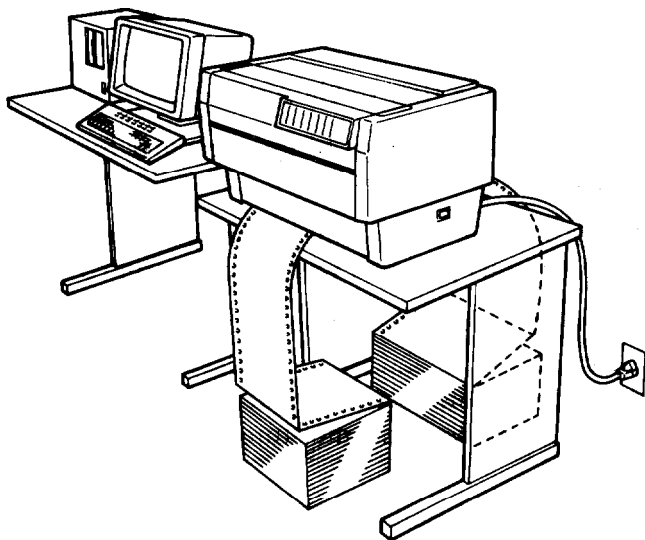

Notes: If you plan to use a printer stand, follow these guidelines to select and set up the stand:

The stand should be able to support at least 128 lbs. (58 kg), which is twice the weight of the DFX-8000 printer.

Never use a stand that supports the printer at an angle. The printer should always be kept level.

If you keep your paper supply underneath the printer stand, be sure there is enough clearance to prevent the paper from catching on the underside of the stand. Also, check to see that the distance between the stand supports is wide enough to accommodate the paper you will be using.

Position your printer's power cable and interface cable so that they do not interfere with paper feeding. If possible, fasten the cables to the printer stand to keep them away from the paper.

Assembling the Printer

After you've decided on the best place to set up your printer, you need to install the ribbon cartridge.

Installing the ribbon cartridge

Before installing the ribbon cartridge, make sure that the printer is not plugged into an electrical outlet. Remove the ribbon cartridge from its box and plastic wrapper and then follow these steps to install the ribbon cartridge:

1. Open the top cover by lifting its front edge up and away from you.

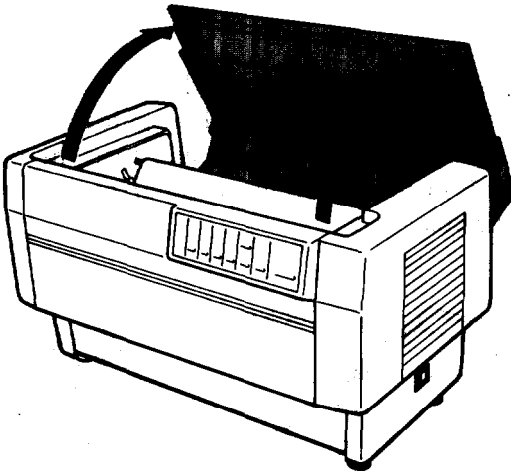

Assembling the Printer

- Slide the print head to the exposed part of the paper bail as shown below.

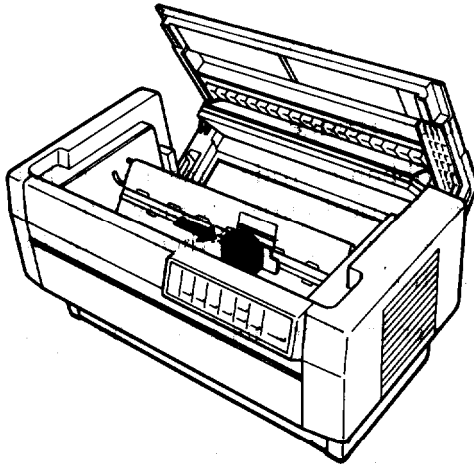

- Remove the separator from **the** middle of the ribbon cartridge and discard it. Then detach the ribbon guide from the ribbon cartridge (but not **from** the **ribbon**) and turn the ribbon-tightening knob in the direction of the **arrow** to take up any slack in the ribbon.

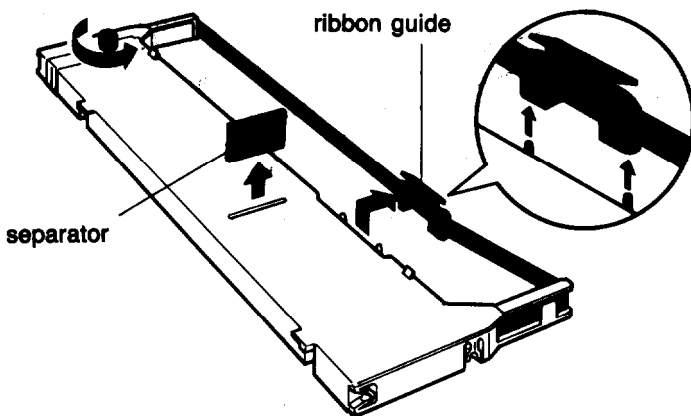

4. Hold the ribbon cartridge with both hands and lower it into the printer. Pulling the cartridge toward you, slide the hooks in the sides of the cartridge over the two corresponding pins in the printer. Then push the cartridge down into position until the other two hooks snap into place over the mounting pins in the printer.

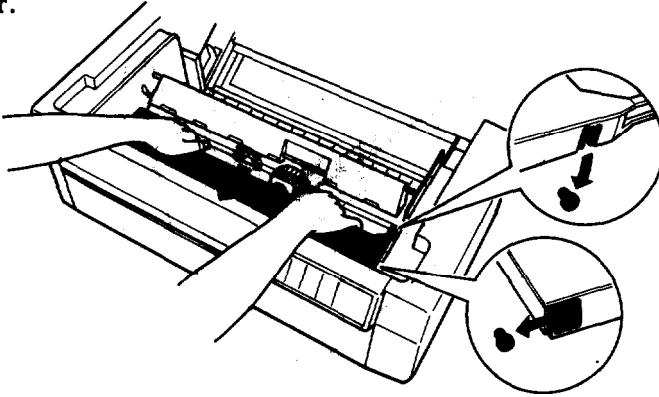

Note: Press lightly on both sides of the cartridge to make sure the hooks are properly connected.

5. Insert the ribbon guide over the metal pins on each side of the print head. The smaller end of the guide should be on top, with its angled edge toward the platen. Turn the ribbon-tightening knob again to remove any slack in the ribbon.

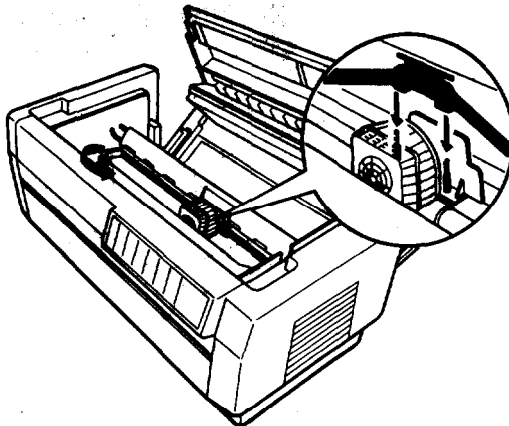

Assembling the Printer

6. Slide the print head from side to side to make sure that it moves smoothly and that the ribbon is not twisted or creased.

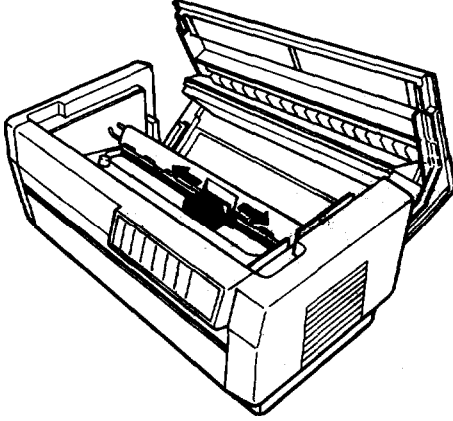

7. Close the top cover.

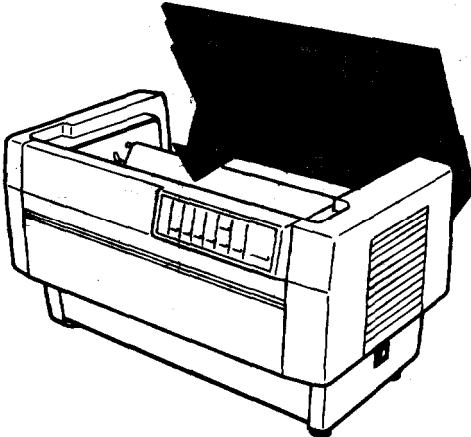

Testing the Printer

Now that your printer is fully assembled, you can use its built-in self test function to be sure the printer is working correctly before you connect it to a computer. You should perform this test to make sure that your printer was not damaged during shipping and that the ribbon is correctly installed.

Before performing the self test, you need to plug in your printer and load paper.

Plugging in the printer

1. Make sure that the printer is turned off.

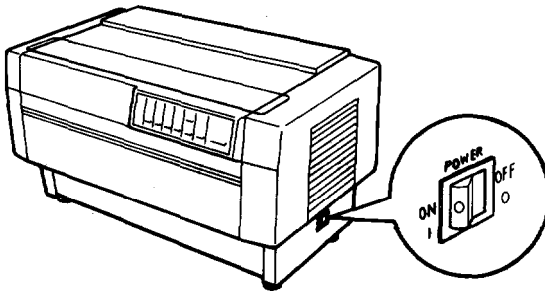

2. Check the label on the printer's back **panel** to make sure the **voltage** required by the printer matches that of your electrical outlet.

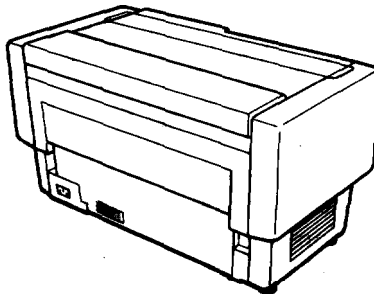



WARNING: If the rated voltage and your outlet voltage do not match, contact your Epson dealer. Do not plug in the power cable.

3. If necessary, connect the power cable to the AC inlet on the printer's rear panel.

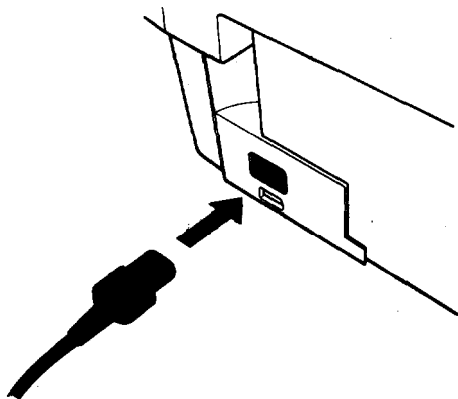

4. Plug the power cable into a properly grounded electrical outlet.

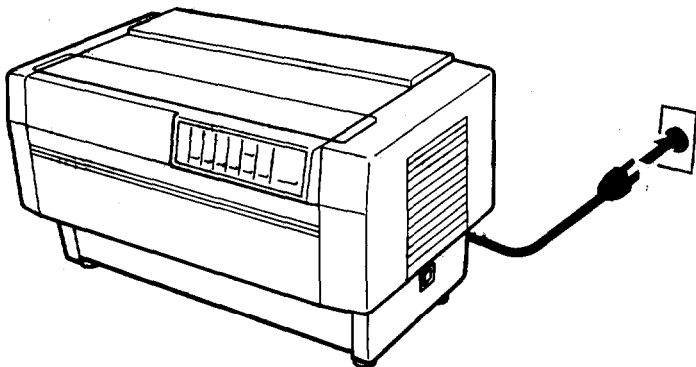

WARNING: Whenever you turn off the power, wait at least five seconds before turning it back on. Rapidly switching the power on and off can damage the printer.

Running the self test

The self test can be run in draft or Near Letter Quality (NLQ) mode, depending on which button you hold down as you turn on the printer.

1. Be sure the printer is turned off.

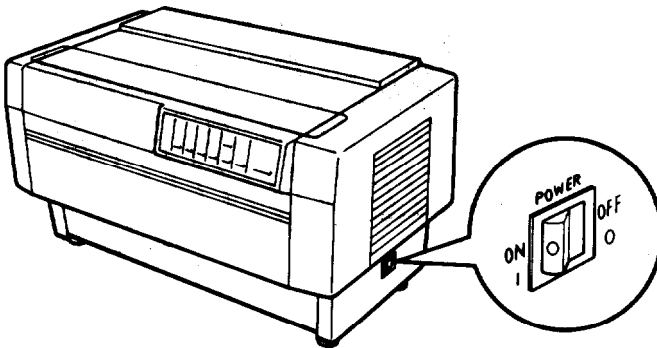

2. Open the front cover by lifting its bottom edge up and toward you.

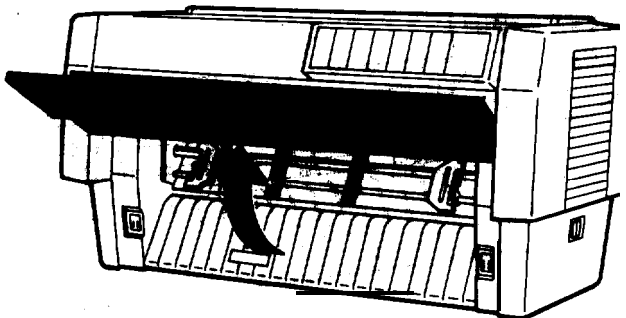

3. Release the sprocket lock levers on both the right and **sprocket units** by pulling each lever down.

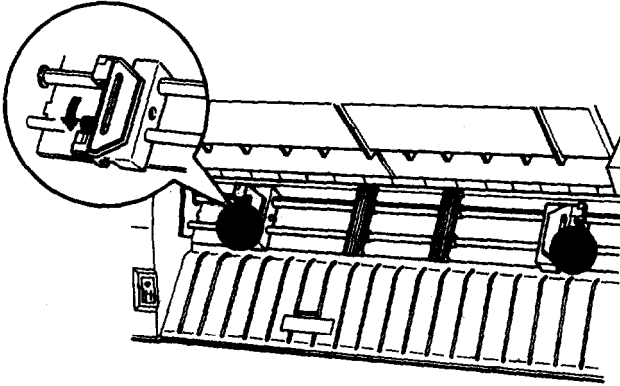

4. Slide the left sprocket unit all the way to the left. Lock it in place by pushing the sprocket lock lever up.

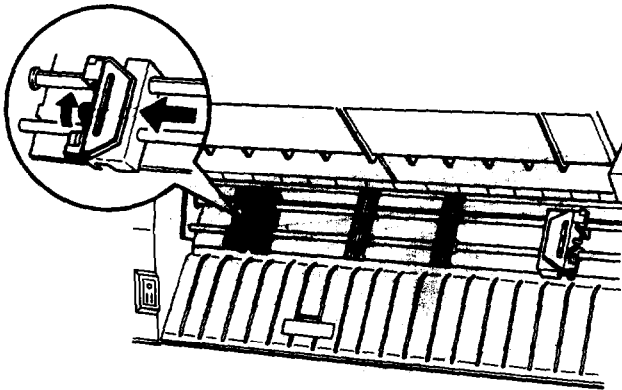

5. Now slide the right sprocket unit to approximately match the width of your paper. (Do not lock it in place yet.)

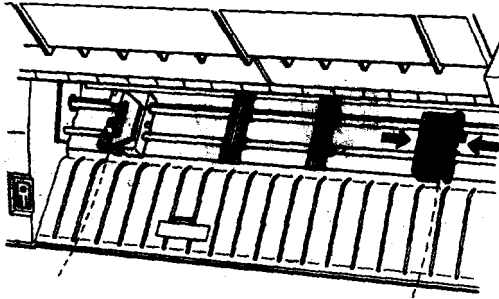

6. Slide the two paper supports so that they are spaced evenly between the two sprocket units.

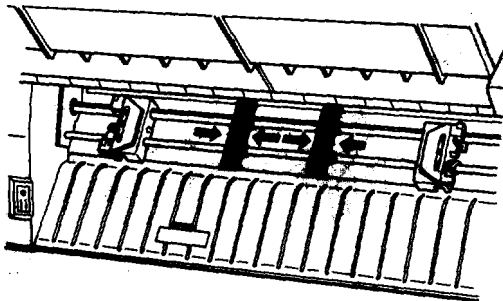

7. Open both sprocket covers.

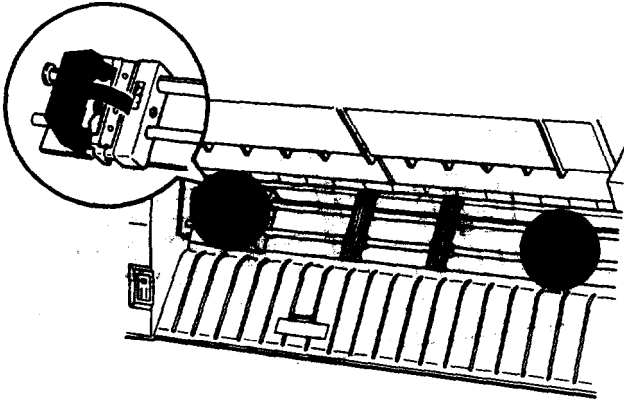

8. Be sure your paper has a clean, straight edge, and then fit the first four holes in the paper over the pins of both sprocket units. Then close the sprocket covers. (The side of the paper that you want to print on should be facing you.)

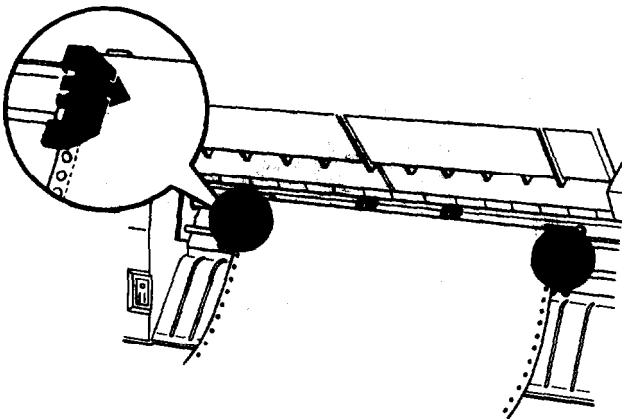

- Slide the right sprocket unit so that the paper is straight and has no wrinkles. Lock the sprocket unit in place by pushing the sprocket lock lever up.

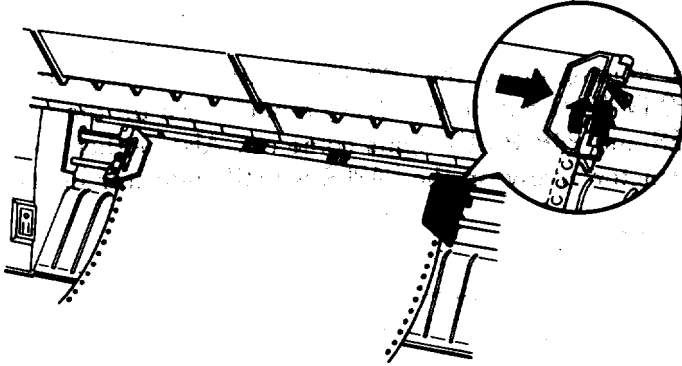

CAUTION: Be sure the sprocket units are not too far apart. If they pull your paper too tightly or if they tear the **edges** of the paper holes, a paper jam may result. To remove any excess tension in your paper, release the right sprocket once and lock it again.

- Close the front cover.

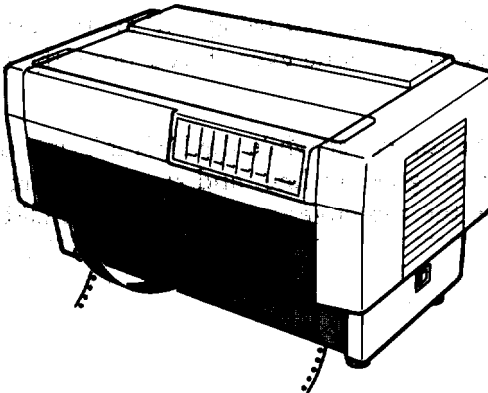



WARNING: Before turning on the **printer**, be absolutely sure you have removed all protective materials. Turning on the printer while the print head cannot move may seriously damage the mechanism.

11. While **holding down** the **LINE FEED** button (for draft mode) or the **FORM FEED** button (for NLQ mode), turn on the printer. The **POWER** and **PAPER OUT** lights come **on**. Also, either the front or rear tractor **arrow on the PAPER SELECT** indicate lights up.

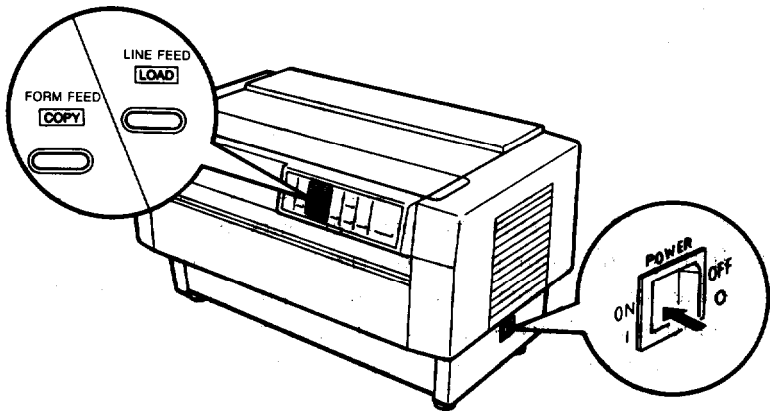

Notes:

- When NLQ mode is selected using DIP switch 1-5, the self test runs in the NLQ mode even if you press the **LINE FEED** button.
- If you open the top cover while the DFX is printing, the printer beeps four times, goes off line, and stops printing. To resume printing, close the top cover and press the **ON LINE** button.

12. Press the **LINE FEED/LOAD** button to load your paper. (If the paper does not load, the front tractor may not be selected. Press the **FRONT/REAR** button to select the front tractor. This loads the paper automatically.)

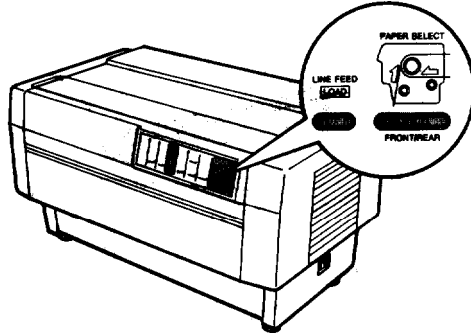

13. Press the **ON LINE** button to start the self test. (The **ON LINE** light does not go on.) A list of your printer's DIP switch settings is printed first, followed by a series of characters. The self test continues until the paper runs out or you press the **ON LINE** button.

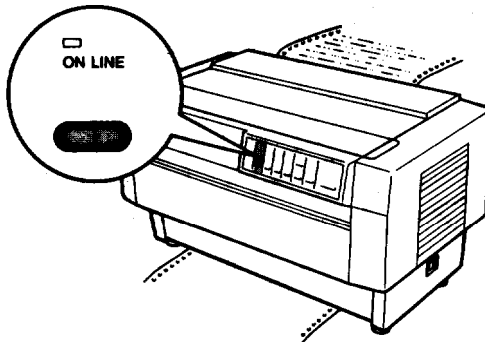

14. If the test results are satisfactory and you wish to stop the test, press the **ON LINE** button. If the test results are not satisfactory, see page **1-24** for possible causes and solutions.

Note: To resume the test, press the **ON LINE** button again.

Testing the Printer

15. Press the **FORM FEED** button to advance the paper. Then open the **paper separator cover** (the back flap of the top cover) and **tear off the paper at the perforation**.

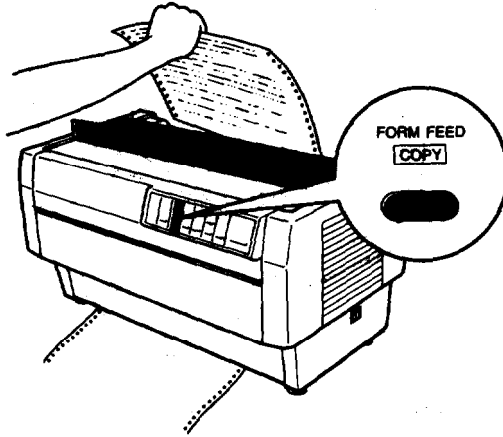

16. Turn off the **printer**.

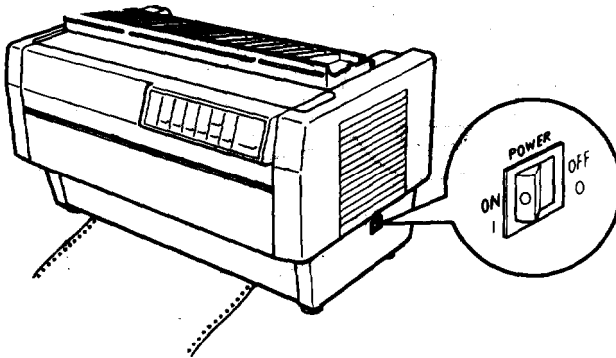

WARNING: Whenever you **turn off** the power, wait at least five seconds before turning it back on. Rapidly switching the Power on **and** off. **can** damage the printer.

Here are parts of typical self test printouts:

High-speed draft mode

Character pitch	Normal	SW1
Shape of zero	Not slashed	SW1
CG table (80H-OFFH)	Italic	SW1
Protocol mode	ESC/P mode	SW1
Print mode	Draft	SW1
S.A.		SW1
*+,-./0123456789:;<=>?@ABCDEFGHIJKLMNO		SW1
*+,-./0123456789:;<=>?@ABCDEFGHIJKLMNO		SW1
*+,-./0123456789:;<=>?@ABCDEFGHIJKLMNO		SW1
*+,-./0123456789:;<=>?@ABCDEFGHIJKLMNO		SW1

Normal draft mode

Character pitch	Normal	SW1
Shape of zero	Not slashed	SW1
CG table (80H-OFFH)	Italic	SW1
Protocol mode	ESC/P mode	SW1
Print mode	Draft	SW1
S.A.		SW1
*+,-./0123456789:;<=>?@ABCDEFGHIJKLMNO		SW1
*+,-./0123456789:;<=>?@ABCDEFGHIJKLMNO		SW1
*+,-./0123456789:;<=>?@ABCDEFGHIJKLMNO		SW1
*+,-./0123456789:;<=>?@ABCDEFGHIJKLMNO		SW1

Note: Your printer's default setting is high-speed draft mode. If you want to run the self test in normal draft mode, you need to select normal draft mode using DIP Switch2-2. See the section on setting DIP switches in Chapter 3 for instructions.

NLQ mode

Character Ditch	Normal	SW1
Shape of zero	Not slashed	SW1
CG table (80H-OFFH)	Italic	SW1
Prot () *+, -./0123456789:; <=> ?@ABCDEFGHIJKLMNO	ESC/P mode	SW1
Prot () *+, -./0123456789:; <=> ?@ABCDEFGHIJKLMNO	ESC/P mode	SW1
%& () *+, -./0123456789:; <=> ?@ABCDEFGHIJKLMNO	ESC/P mode	SW1
& () *+, -./0123456789:; <=> ?@ABCDEFGHIJKLMNO	ESC/P mode	SW1
() *+, -./0123456789:; <=> ?@ABCDEFGHIJKLMNO	ESC/P mode	SW1
() *+, -./0123456789:; <=> ?@ABCDEFGHIJKLMNO	ESC/P mode	SW1

Solving any self test problems

If the self test does not print properly, check the list of possible problems and solutions below. Also be sure there are no packing materials remaining inside **the printer**.

Problem

Solution

The paper is jammed.

Turn off the printer, remove the jammed paper, and then load fresh paper. See page 1-15.

The printer does not print.

The printer sounds like it is printing, but nothing is printed.

The ribbon cartridge may not be installed properly. Turn off the printer and remove **the** ribbon cartridge. Then reinstall it and take up any slack in the ribbon.
See page 1-9

The ribbon may be worn out. Replace **the** ribbon cartridge. See page 6-4.

The test did not print when you pressed the *ON LINE* button.

Turn off the printer and follow the steps under **Running** the Self Test **again**. Be sure to hold down the **FORM FEED** or **LINE FEED** button longer while you turn on the printer. See page 1-20

Problem	Solution
<p>The printout is faint or uneven.</p> <p>The printout is faint.</p> <p>Parts of printed characters are missing, as shown here:</p> <p style="text-align: center;">ABCD</p>	<p>The ribbon may be worn out. A worn ribbon can damage the print head and should be replaced. Install a new ribbon cartridge as soon as possible. See page 6-4.</p> <p>There is either too much slack in the ribbon or the ribbon is caught on something. Stop printing, turn off the printer, and reinstall the ribbon cartridge. See page 1-9.</p>
<p>The bottom parts of printed characters are missing as shown here:</p> <p style="text-align: center;">ABCD</p>	<p>The ribbon cartridge may not be installed properly. Turn off the printer, remove the ribbon cartridge, and then reinstall it. Make sure the cartridge hooks are inserted securely into the printer. See page 1-11.</p>
<p>A blank line runs through your characters, as shown here:</p> <p style="text-align: center;">ABCD</p>	<p>The print head is damaged. Stop printing and contact your Epson dealer to have the print head replaced.</p>

If the printer still does not print the self test correctly, contact your Epson dealer.

Connecting the Printer to Your Computer

If the self test printed correctly, you are now ready to connect your printer to the computer.

Your DFX printer **has** two separate interface connections: a parallel interface and an RS-232C compatible serial interface. If you are not sure which one is required by your computer, check your computer manual.

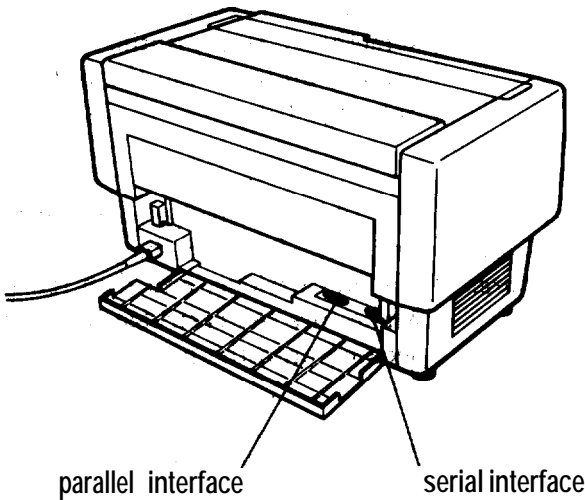

If you have a suitable shielded cable, you should be able to connect the printer to most computers immediately. If your computer requires another type of interface, you need to use an optional interface board. See the section on interface boards in Chapter 5.

The parallel interface is the printer's default setting. If you need to use **the built-in serial interface**, be sure to change the DIP switch settings as **shown** in Chapter 3.

The parallel interface

Follow these steps to connect the parallel interface cable to the printer:

1. Turn off both the printer and computer.

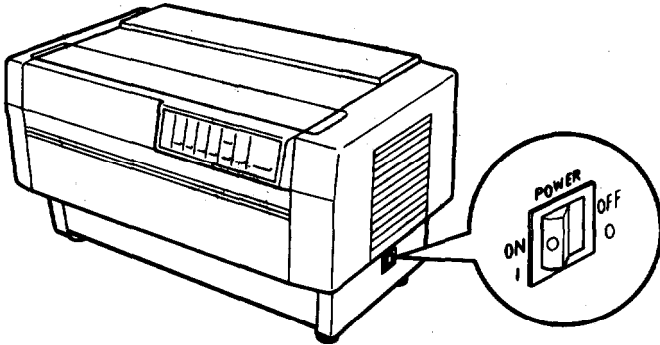

2. Open the rear cover by grasping it by the handholds on each side and pulling it out and down.

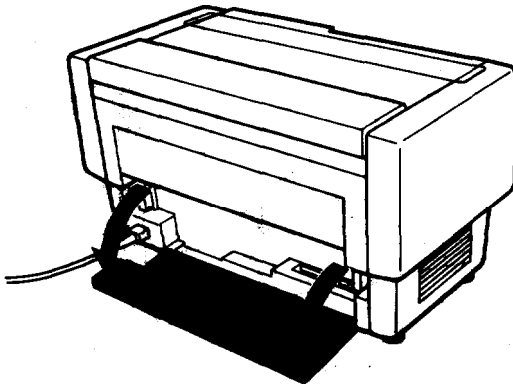

Connecting the Printer to Your Computer

3. Plug the cable connector securely into the parallel interface (the socket on the left).

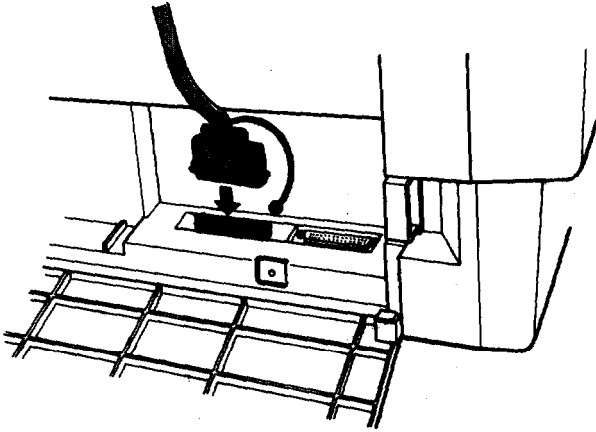

WARNING: Do not plug more than one interface cable into the printer at one time. This may damage the printer.

4. Squeeze the wire clips together until they lock in place on either side of the connector.

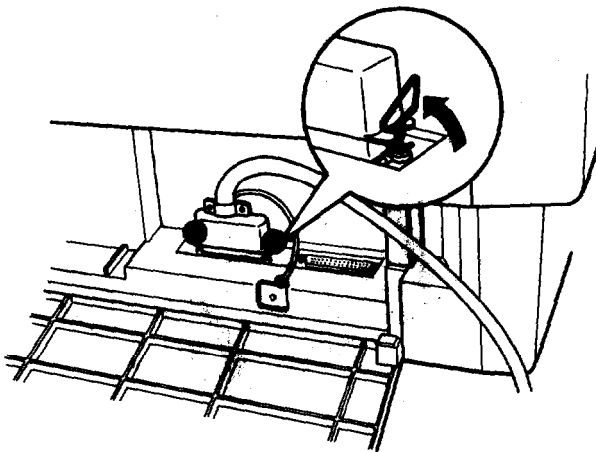

printers

5. If your cable has a ground wire, connect it to the ground connector.

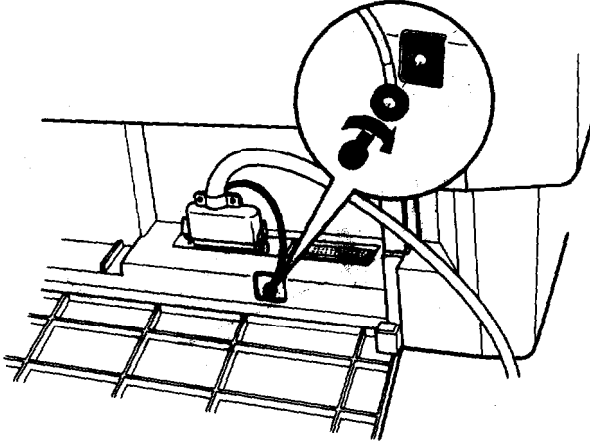

6. Open the plastic clamp to the right of the parallel and serial interfaces by pressing down on its top tab. Insert the cable in the plastic clamp and close the clamp.

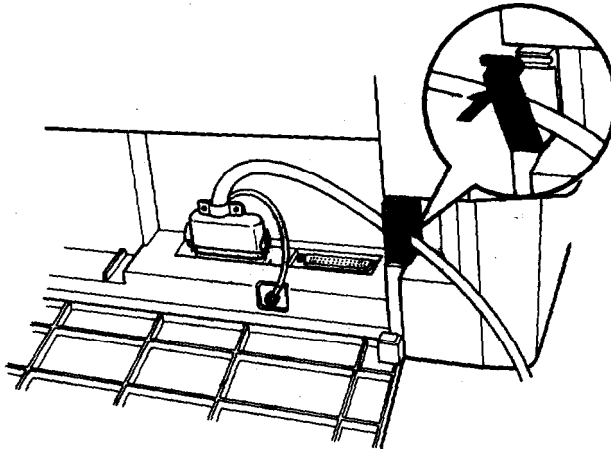

Connecting the Printer to Your Computer

7. Close the rear cover.

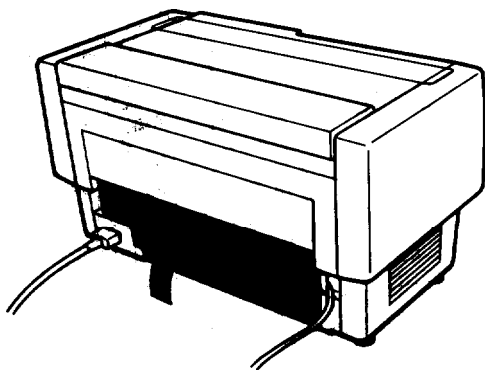

CAUTION: Always close the rear cover before using the printer.

8. Plug the other end of the cable into the computer. (If there is a ground wire at the computer end of the cable, attach it to the ground connector at the back of the computer.)

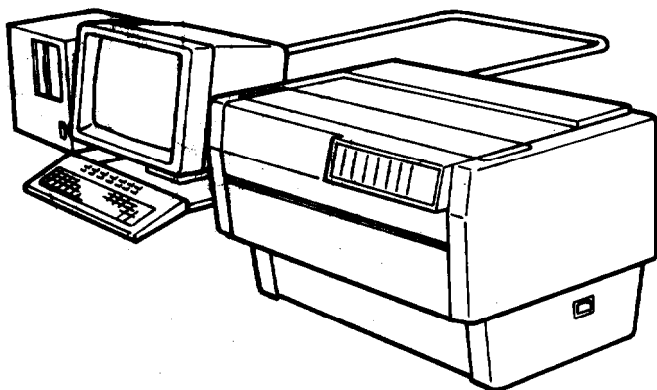

The serial interface

Follow these steps to connect the serial interface cable to the printer:

1. Turn off both the printer and computer.

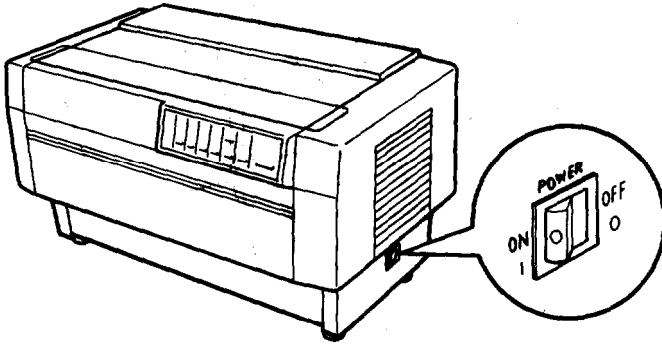

2. Open the rear cover by grasping it by the handholds on each side and pulling it out and down.

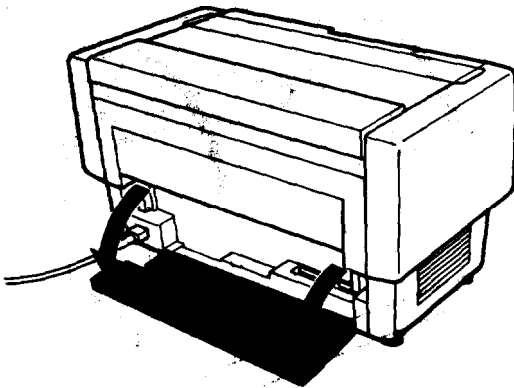

Connecting the Printer to Your Computer

3. **Plug** the cable connector securely into the serial **interface** (the socket on the right).

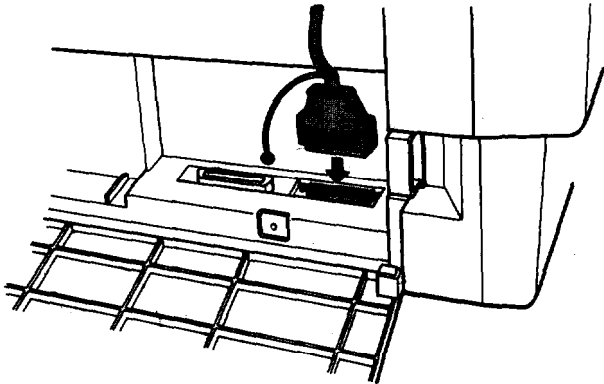

WARNING: Do not plug more than one interface cable into the printer at one time. This may damage the printer.

4. If your cable connector has screws that you need to tighten using a screwdriver, open the top cover of the printer.

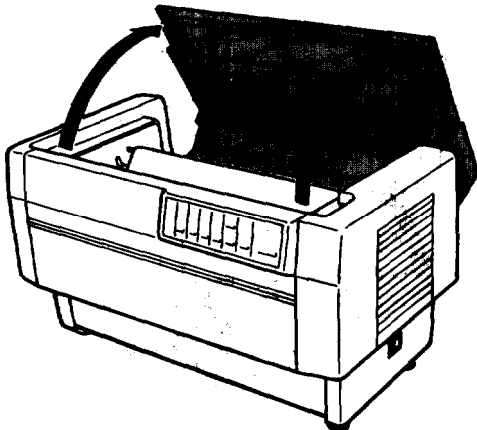

5. Insert a screwdriver through the hole in the rear paper guide and fasten the screws of the cable connector.

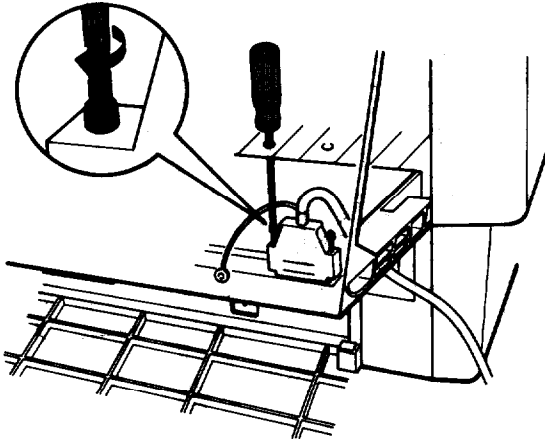

Note: If the screws that come with the cable do not fit into the connector lock nuts on the interface, replace the lock nuts with the optional lock nuts provided with the printer.

6. Close the top cover.

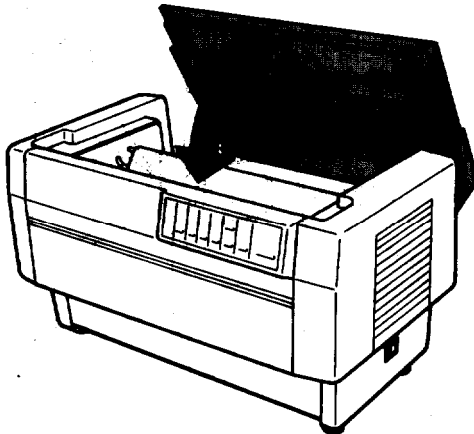

Connecting the Printer to Your Computer

7. If your cable has a ground wire, connect it to the printer's ground connector.

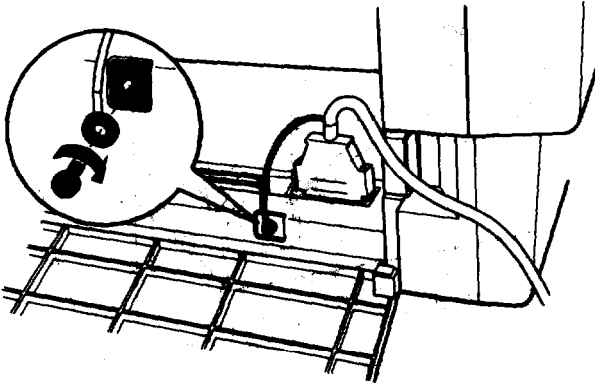

8. Open the plastic clamp to the right of the parallel and serial interfaces by pressing down on its top tab. Insert the cable in the plastic clamp and close the clamp.

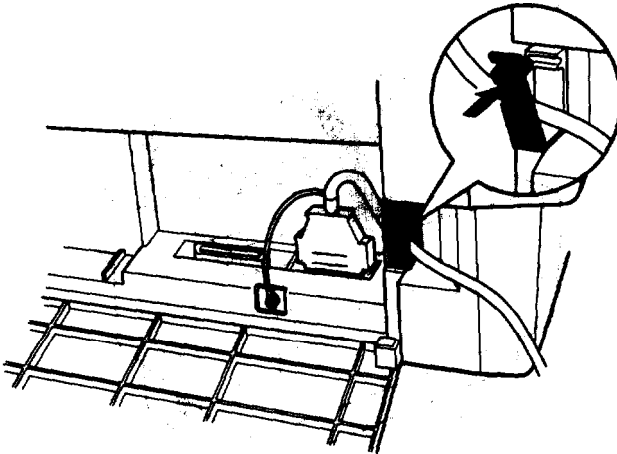

9. Close the rear cover.

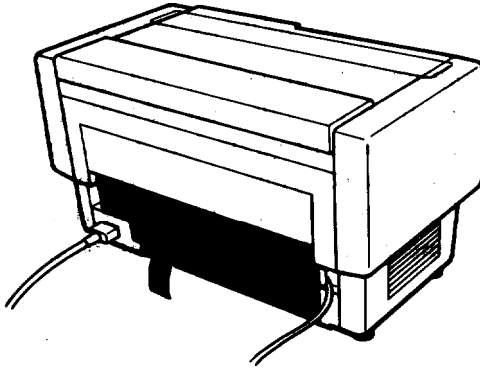

CAUTION: Always close the rear cover before using the printer.

10. Plug the other end of the cable into the computer. (If there is a ground wire at the computer end of the cable, attach it to the ground connector at the back of the computer.)

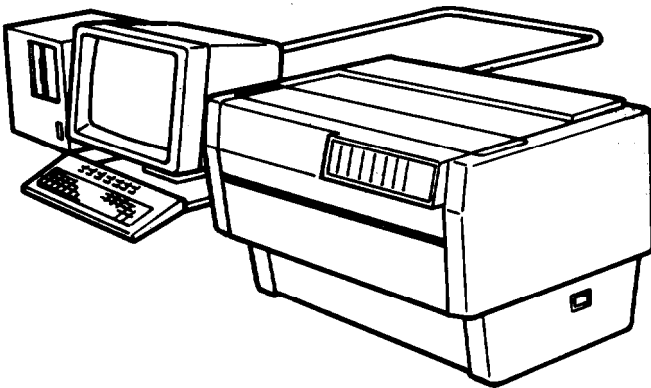

Setting Up Your Application Software

Now that you have set up and tested the DFX-8000, you can start using it with your application software programs.

Most software programs let you specify the type of printer you are using so that the program can take full advantage of the printer's features. If your application program has an installation or setup procedure that lets you select your printer from a list of printers, choose the Epson DFX-8000 printer. If the list does not include the DFX-8000, choose one of the following' printers, listed in order of preference:

DFX-5000

FX-1050 (FX-850)

FX-286e (FX-86e)

Ex-1000 (EX-800)

FX-185 (FX-85)

FX-100+ (FX-80+)

FX-100 (FX-80)

If these printers are not listed, select one of the following printers, listed in order of preference:

FX

EX

LX

RX

MX

Epson printer

9-pin printer

Standard printer

Draft printer

If you plan to use IBM emulation mode, select one of the following printers, listed in order of preference:

IBM Proprinter XL

IBM Graphics printer

IBM Printer

Note: To use all the features of the DFX-8000, it is best to use a program with **the** DFX-8000 on its menu. If your software program does not list the DFX-8000, contact the software manufacturer to see if an update is **available**.

Chapter 2

Paper Handling

Using the Two-Tractor System	2-2
Positioning the paper supply	2-2
Loading paper onto the front tractor	2-4
Loading paper onto the rear tractor.....	2-11
Switching between Front and Rear Tractors	2-20
Changing the paper	2-24
Printing on Special Paper	2-29
Copy mode.....	2-29
Multi-part forms	2-30
Labels	2-32



Using the Two-Tractor System

The DFX-8000's paper handling system consists of a front and a rear push tractor. Both tractors are easy to load and operate, and both accommodate a wide variety of paper types, including labels and multi-part forms. The printer automatically adjusts to the thickness of your loaded paper, so you don't need to set the paper thickness manually. You can use any width continuous paper, from 4 inches (101 mm) to 16 inches (406 mm) wide. Your printer also senses the paper width automatically.

If you plan to use more than two types of paper, it is best to load the paper you use most often onto the rear tractor. That way you can use the front tractor, which is easier to reach, for paper you change more often.

Positioning the paper supply

Since the DFX-8000 can be loaded with continuous paper from both the front and the rear, be sure to leave enough room around the printer for two stacks of fresh paper and a third stack of printed output. It is also important to keep your stacks of fresh paper aligned with the paper loaded in the tractor so that the paper feeds smoothly into the printer.

The following illustration shows three ways to position your printer and paper: with the front tractor loaded, with the rear tractor loaded, and with both tractors loaded.

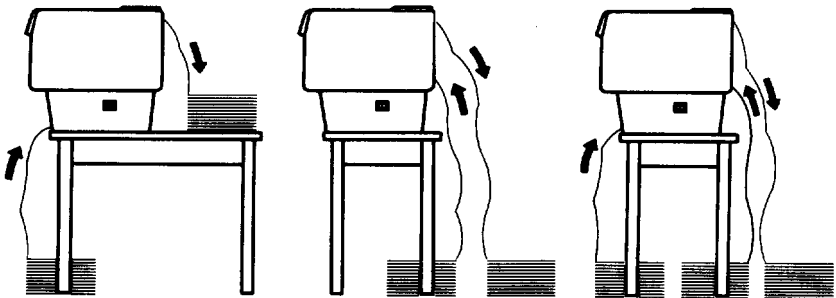



CAUTION: Make sure that your stack of printed pages does not interfere with the rear tractor's paper supply.

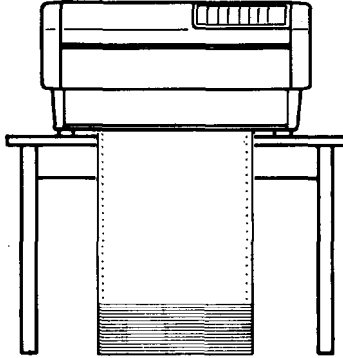

front-loaded paper

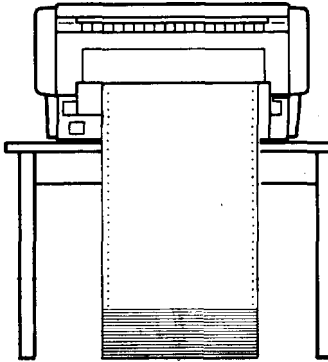

rear-loaded paper



CAUTION: Be sure your printed output folds properly as it comes out of the printer. It should fold at the perforation between **pages**.

Loading paper onto the front tractor

The following steps show you how to load paper onto the front tractor.

1. Turn off the printer.

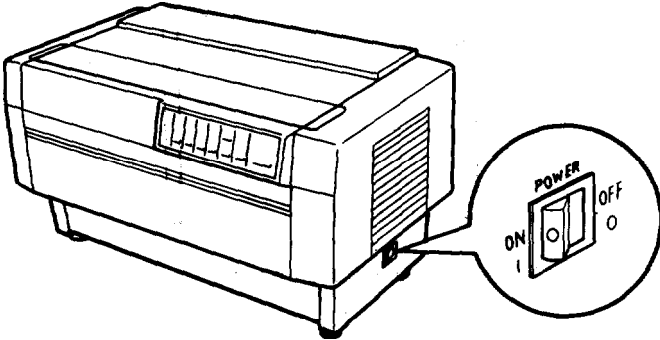

2. Open the front cover by lifting its bottom edge up and toward you.

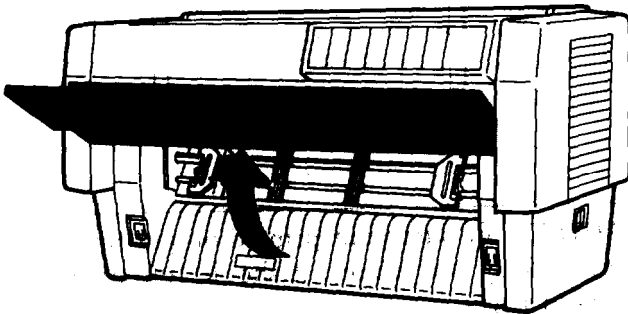

3. Release the sprocket lock levers on both the right and left sprocket units by pulling each lever down.

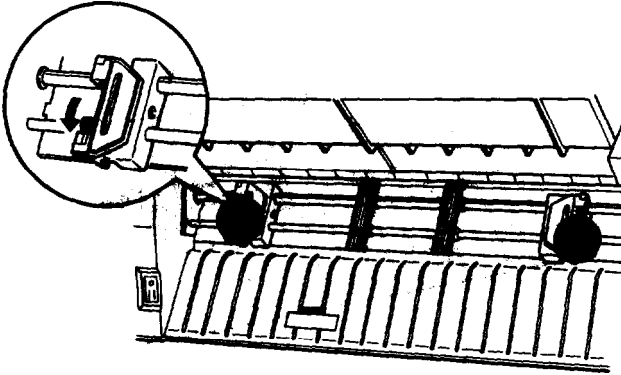

4. Slide the left sprocket unit all the way to the left., Lock it in place by pushing the sprocket lock lever up.

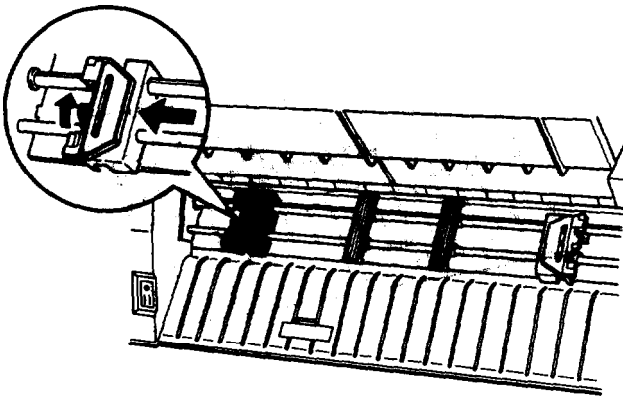

Using the Two-Tractor System

5. Now slide the right sprocket unit to approximately match the width of your paper. (Do not lock it in place yet.)

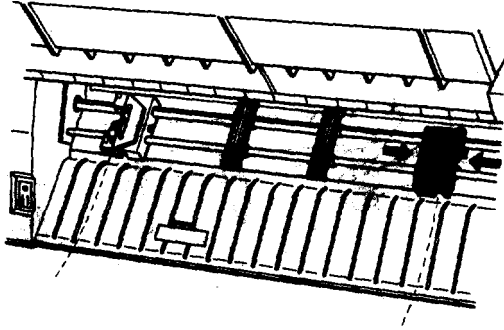

6. Slide the two paper supports so that they are spaced evenly between the two sprocket units.

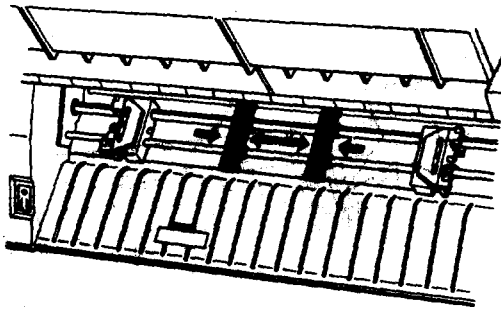

7. Open both sprocket covers.

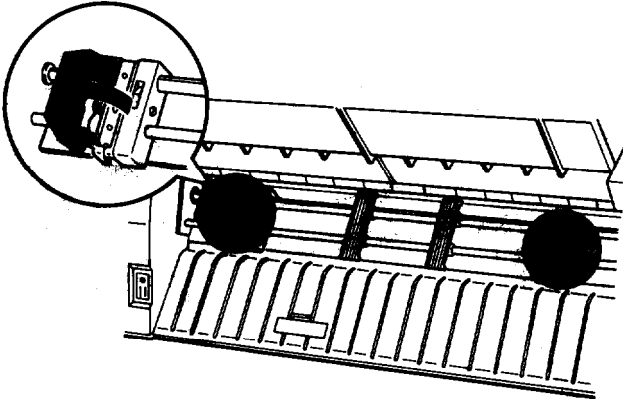

8. Fit the first four holes in the paper over the pins of both sprocket units. (The side of the paper that you want to print on should be facing you.). Then close the sprocket covers.

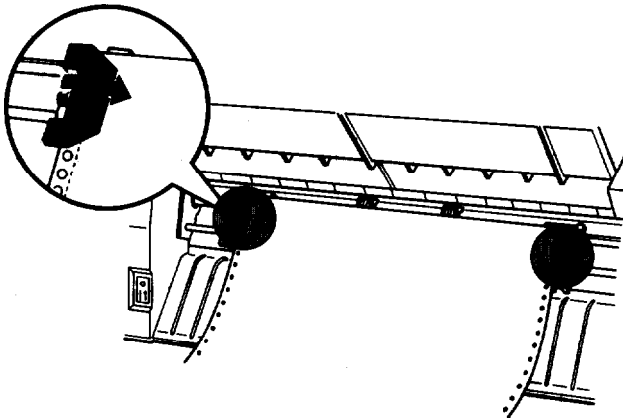

CAUTION: Make sure your paper has 'a clean, straight edge before inserting it into the printer.

Using the Two-Tractor System

- Slide the right sprocket unit so that the paper is straight and has no wrinkles. Then lock the sprocket unit in place by pushing the sprocket lock lever up.

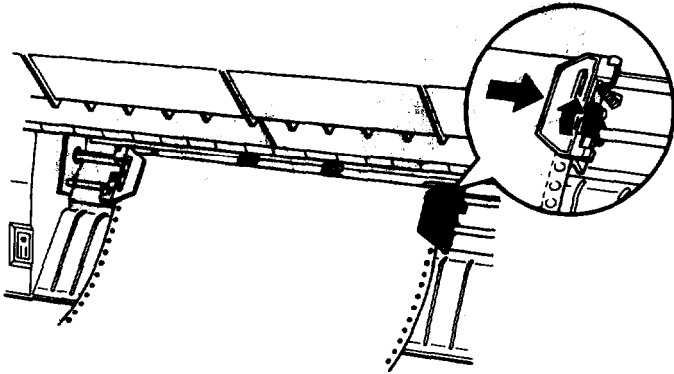

CAUTION: Be sure the sprocket units are not too far apart. If they pull your paper too tightly or tear the edges of the paper holes, a paper **jam** may result. To remove any excess tension in your paper, release the right sprocket and lock it again.

- Close the front cover. The paper is now loaded to the standby position.

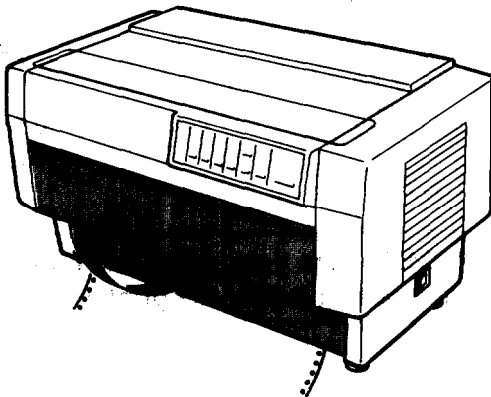

11. Turn **on** the printer. The **POWER** and **PAPER OUT** lights go on. Also, either the front or rear tractor **arrow** on the **PAPER SELECT** indicator lights up, depending on **which** tractor was selected when the printer was turned off last,

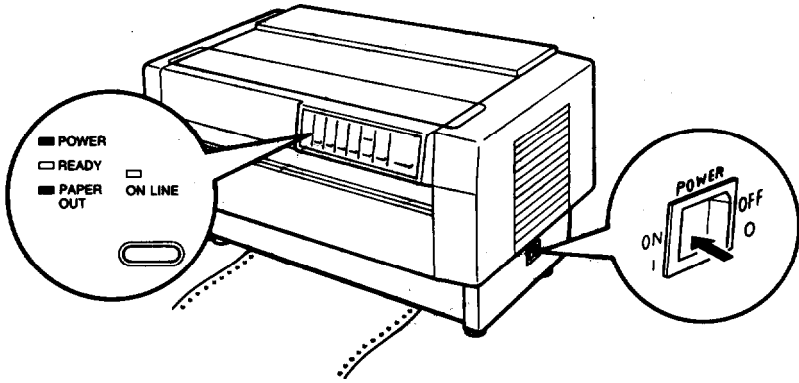

12. Check the **PAPER SELECT** indicator to see which tractor is selected:
- If the front tractor arrow is lit up, press the **LINE FEED/LOAD** button to load the paper.

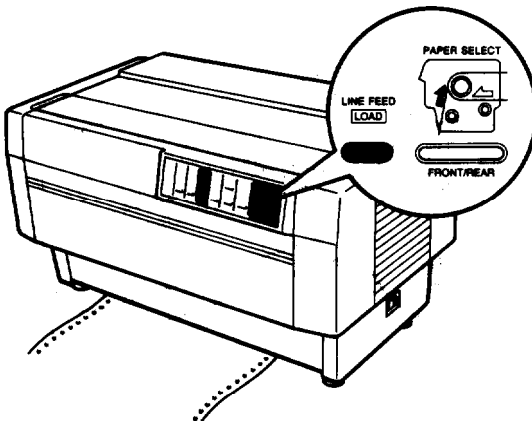

Using the Two-Tractor System

- If the rear tractor arrow is lit up, make sure the printer is **off line** and then press the **FRONT/REAR** button to switch to the front tractor. When the printer switches tractors, it also loads the paper automatically.

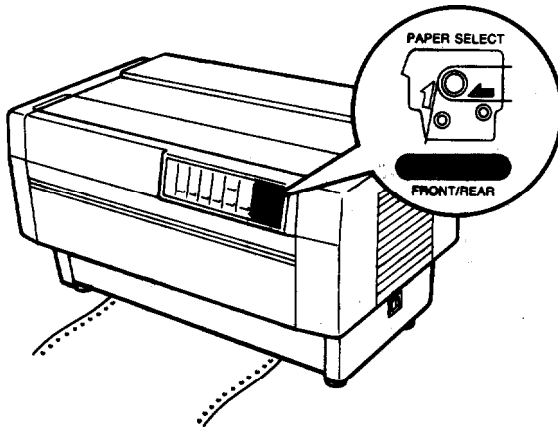

13. Press the **ON LINE** button to put the printer on line so it is ready to print. The paper is now loaded to the top of form position. If it looks like the printing will start too high or low **on** the page, see the section on **adjusting the** top of form position in Chapter 3.

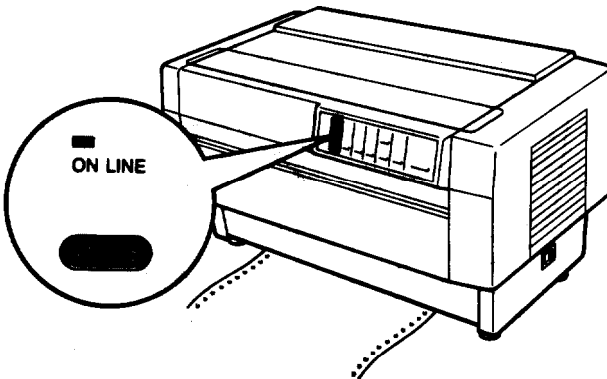

Notes:

- Before you begin printing, be sure to check the page length and skip over perforation settings, and readjust the settings if necessary. See the sections **on** page **length** and skip over perforation in Cha#qr 3.
- If you open the top cover while the DFX is printing, the printer beeps four times, goes off line, and stops printing. To resume printing, close the top cover and press the **ON LINE** button.

Loading paper onto the rear tractor

The following steps show you how to load paper onto the rear tractor. You can load **paper onto the rear** tractor without removing the paper from the front **tractor**.

1. Turn off the printer.

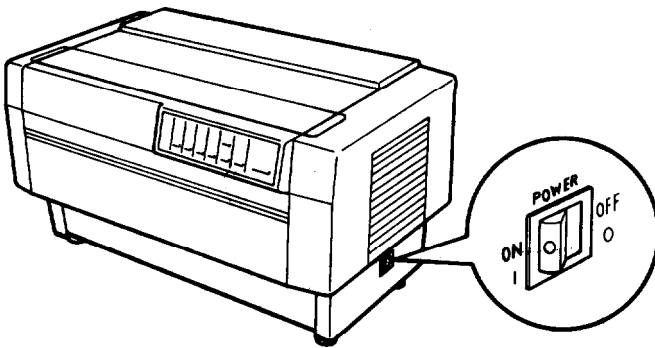

Using the Two-Tractor System

2. Open the top cover by lifting its front edge up and away from you.

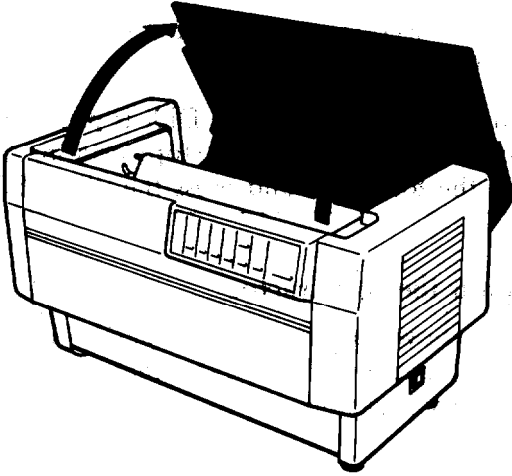

3. Open the rear flap at the back of the top cover.

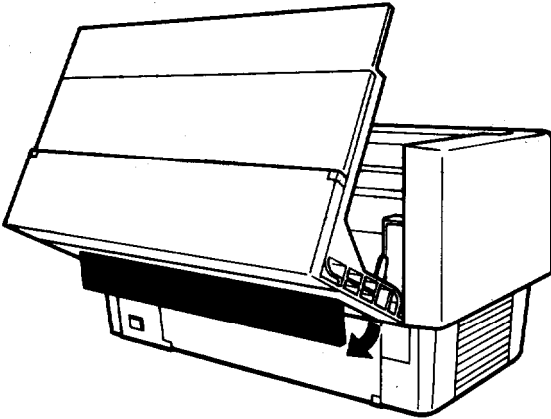

release the sprocket lock levers

4. **Facing the front of the printer,** on the rear tractor's right and left sprocket units by Pushing each lever back.

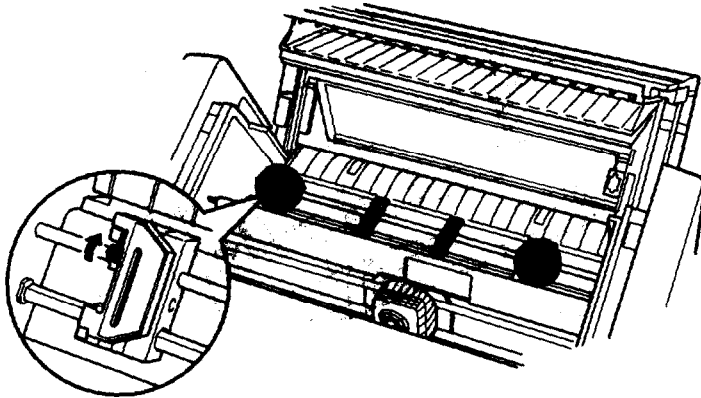

5. Slide the left sprocket unit all the way to the left. Lock it in place by pulling the sprocket lock lever forward.

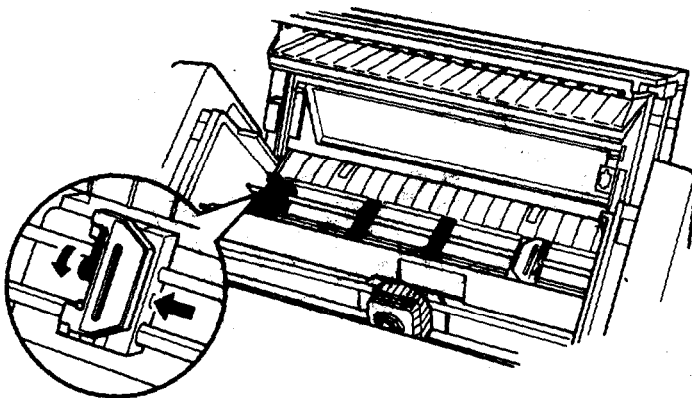

Using the Two-Tractor System

6. Now slide the right sprocket unit to approximately match the width of your paper. (Do not lock it in place yet.)

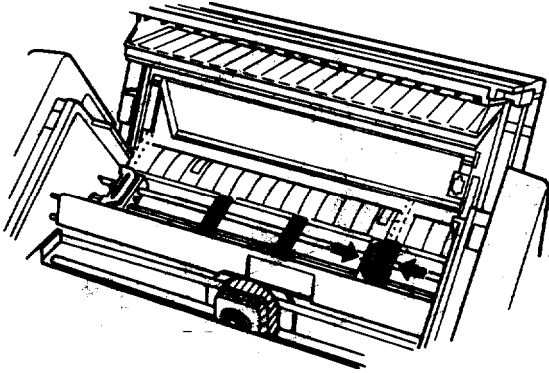

7. Slide the two paper supports so that they are spaced evenly between the two sprocket units.

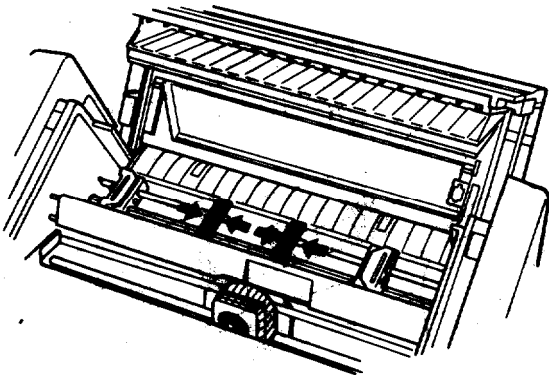

8. Open both sprocket covers.

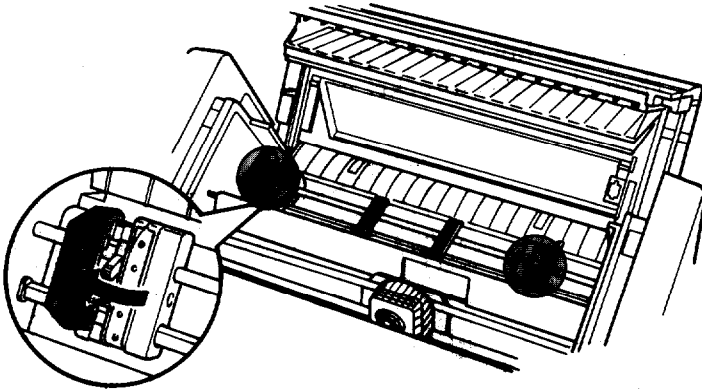

9. With the side of the paper you want to print on facing down, insert the paper through the opening at the rear of the printer. You may find it easier to load the paper by standing to the side of the printer. That way, you can feed the paper through the rear opening with one hand and pull it through with the other.

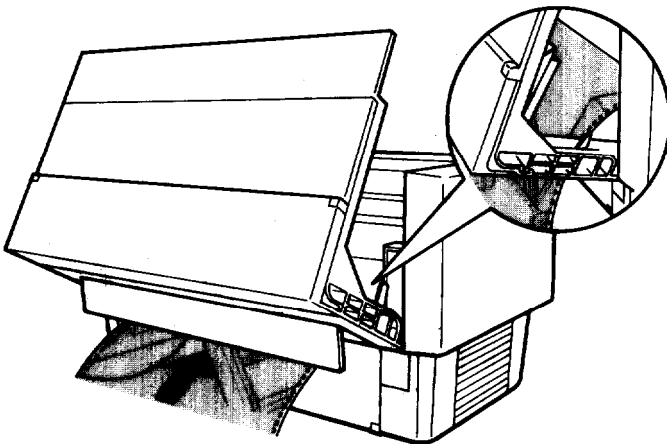



CAUTION: Make sure your paper has a clean, straight edge before inserting it into the printer.

10. Fit the first four holes in the paper over the pins of the sprocket units. Then close the sprocket covers.

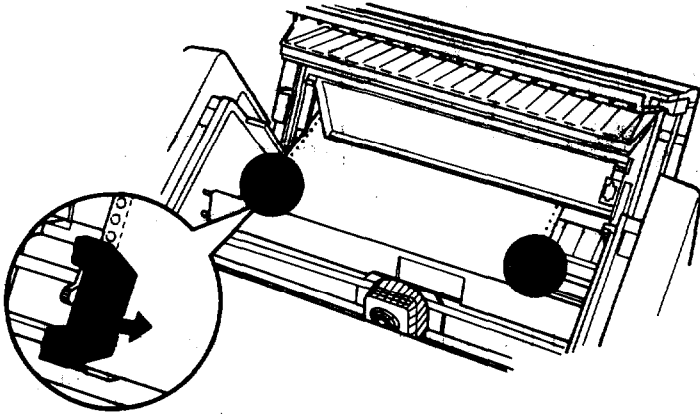

11. Slide the right sprocket unit so that the paper is straight and has no wrinkles. Then lock the sprocket unit in place by pulling the sprocket lock lever forward.

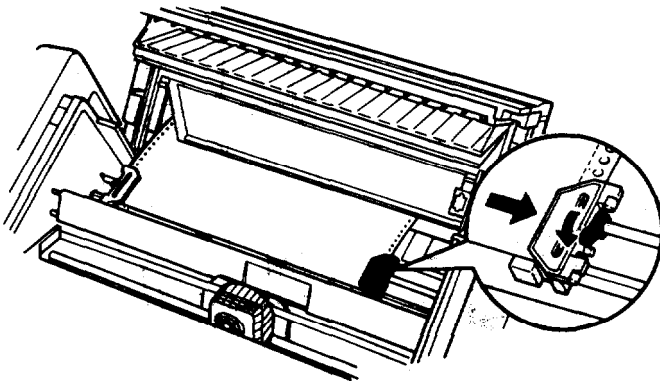



CAUTION: Be sure the sprocket units are not too far apart. If they pull your paper too tightly or tear the edges of the paper holes, a paper jam may result. To remove any excess tension in your paper, release the right sprocket and lock it again.

12. Close the top cover and the rear flap. The paper is now loaded to the standby position.

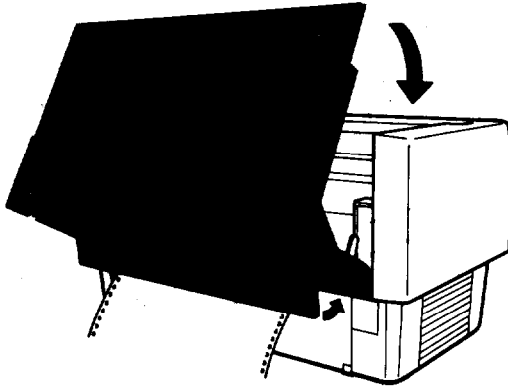

13. Turn on the printer. The **POWER** and **PAPER OUT** lights go on. Also, either the front or rear tractor **arrow** on the **PAPER SELECT** indicator lights up, depending on which tractor was selected when the printer was turned off last.

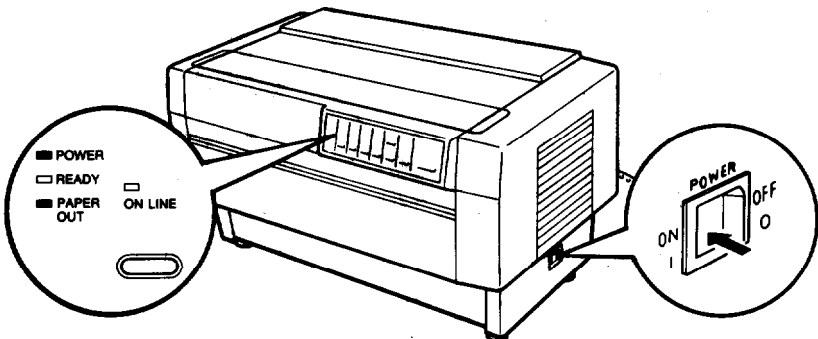

Using the Two-Tractor System

14. Check the PAPER SELECT indicator to see which tractor is selected:

If the rear tractor arrow is lit up, press the LINE FEED/LOAD button to load the paper.

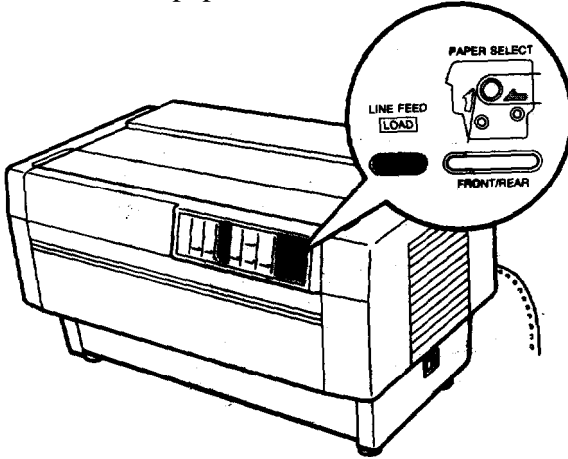

- If the front tractor arrow is lit up, make sure the printer is off line and then press the FRONT/REAR button to switch to the rear tractor. When the printer switches tractors, it also loads the paper automatically.

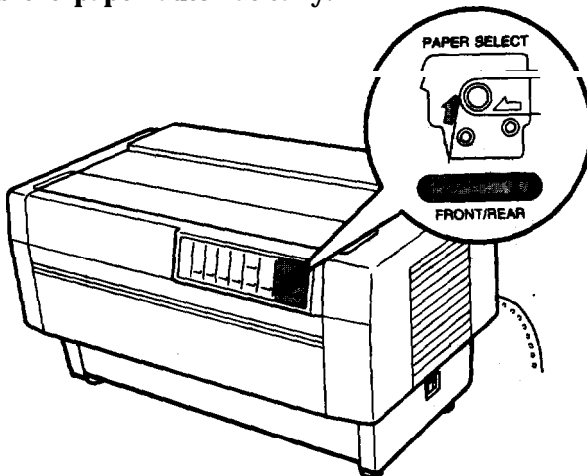

15. Press the **ON LINE** button to put the printer on line so it is ready to print. The paper is now loaded to the top of form position. If it looks like the printing will start too high or low on the page, see the section on adjusting the top of form position in Chapter 3.

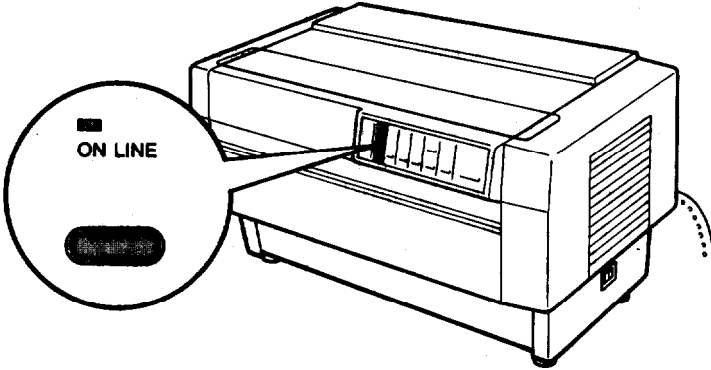

Notes:

- Before you begin printing, be sure to check the page length and skip over perforation settings, and readjust the settings if necessary. See the section on page length and skip over perforation in Chapter 3.
- If you open the top cover while the DFX is printing, the printer beeps four times, goes off line, and stops printing. To resume printing, close the top cover and press the **ON LINE** button.

Switching between Front and Rear Tractors

You can easily switch between paper loaded on the front tractor and paper loaded on the rear tractor with the **FRONT/REAR** button.

The following steps describe the procedure for switching from the front tractor to the rear tractor, but you can follow the same steps to switch from the rear tractor to the front tractor. (To switch tractors when the optional pull tractor is installed, see Chapter 5.)



WARNING: Never switch between tractors when labels are loaded in the printer or a paper jam may result. Instead, completely remove the labels first by tearing off the fresh supply below the tractor and pressing the **FORM. FEED** or **LINE FEED** button to eject the remaining labels.

Before you start, make sure the printer is turned on and that the front tractor is selected. (The front tractor **arrow** on the **PAPER SELECT** indicator should be lit up.) If you are in the middle of printing a document, wait for the printer to finish printing before you switch tractors. Then follow these steps.

1. If the printer is on line, press the **ON LINE** button to take it off line.

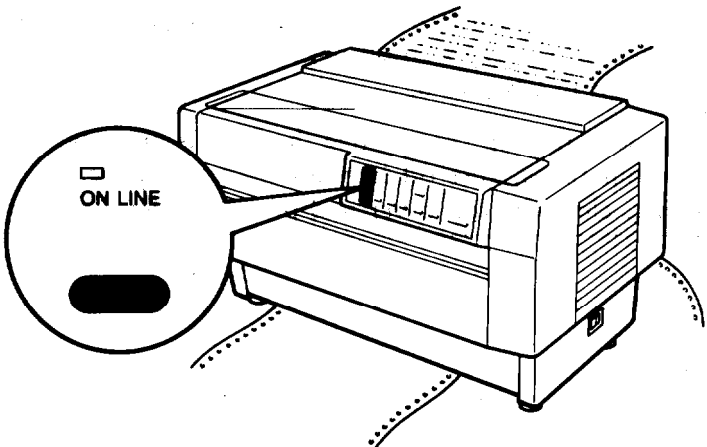

Switching between **Front and Rear Tractors**

2. If there is no paper loaded in the rear tractor, load paper to the standby position. (See the section on loading paper onto the rear tractor in this chapter for instructions.)
3. Open the paper separator cover at the back of the top cover.

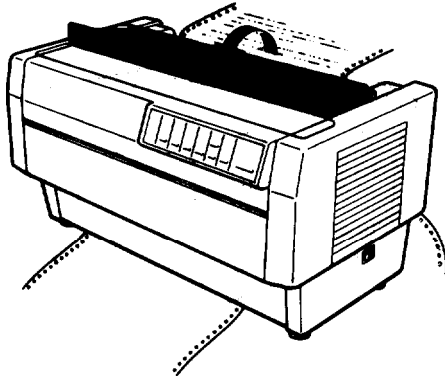

4. If you have a printed document still in the printer, or excess paper that has been fed through the printer, use the short tear-off feature **described** in Chapter 3 to tear off the document or excess paper.

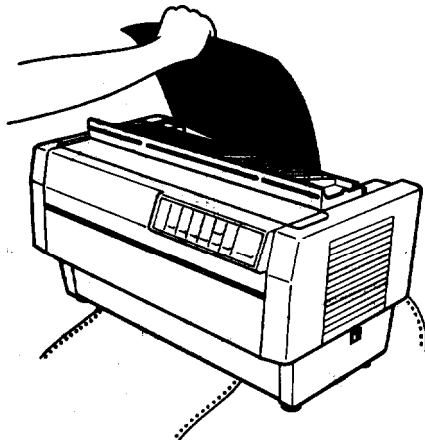

Switching between Front and Rear Tractors



WARNING: Always tear off the printed document and any excess paper that has been fed through the printer before switching tractors. Never feed more than one page backward through the printer.

5. Close the paper separator cover.

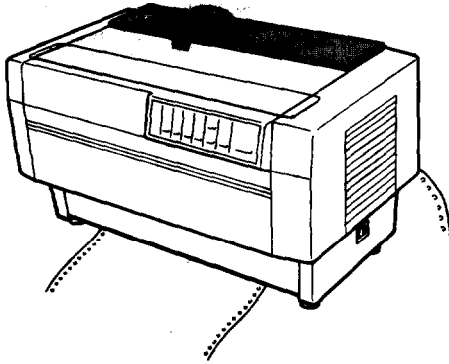

6. Make sure the top cover is closed and then press the **FRONT/REAR** button to switch to the rear tractor. The printer feeds the front-loaded paper back to the standby position and advances the rear-loaded paper to the top of form position.

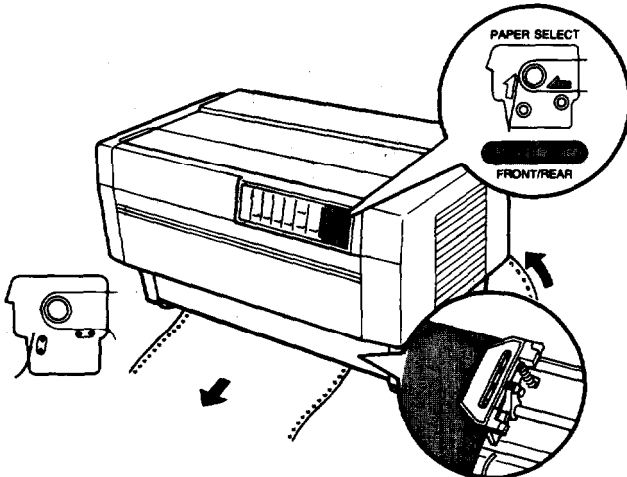

Switching between Front and Rear Tractors

7. Press the **ON LINE** button to put the printer on line so it is ready to print.

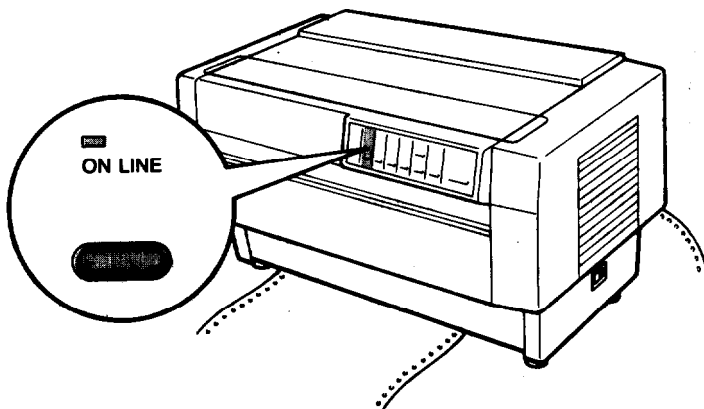

Note: If you open the top cover while the DFX is printing, the printer beeps four times, goes off line, and stops printing. To resume printing, close the top cover and press the **ON LINE** button.

Changing the Paper

The following steps describe the procedure for changing paper on the front tractor, but you can follow the same steps when you change the paper on the rear tractor. Before you start, make sure the printer is turned on and the front tractor is selected. (If you are changing the paper on the rear tractor, the rear tractor should be selected instead.)



WARNING: Never change paper using the following procedure if labels are already loaded in the printer. Instead, completely remove the labels first by tearing off the fresh supply below the tractor and pressing the **FORM FEED** or **LINE FEED** button to eject the remaining labels. Then load new paper as described in this chapter,

1. If the printer is on line, press the **ON LINE** button to take it off line.

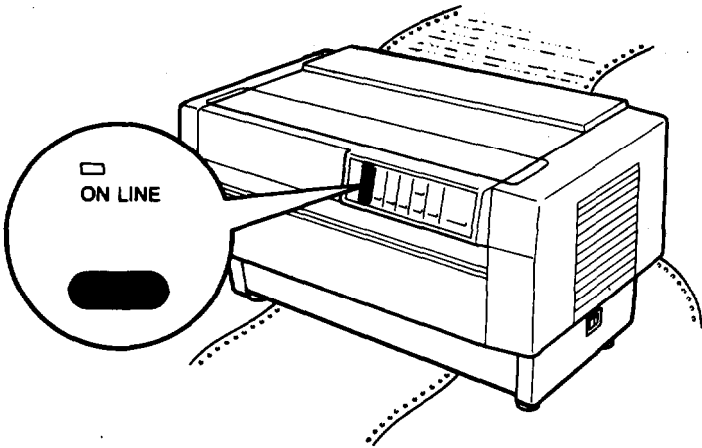

2. If you **have** a printed document still in the printer, or excess paper that has been fed through the printer, use the short tear-off feature described in Chapter 3 to tear off the document or excess paper.

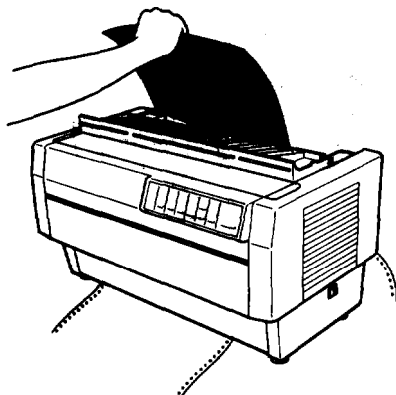

WARNING: Always tear off printed documents before changing the paper. Never feed more than one page backward through the printer.

3. Press the **FRONT/REAR** button to switch to the rear tractor. The front-loaded paper automatically feeds back to the standby position.

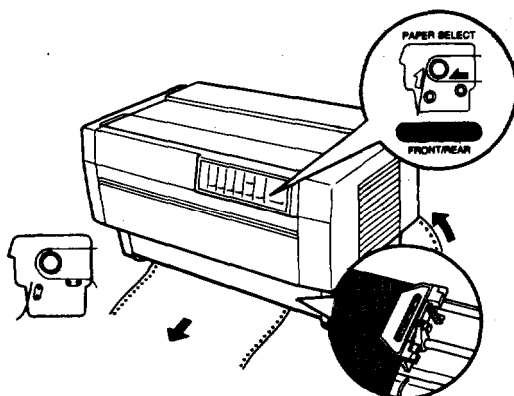

Changing the Paper

4. Open the front cover. (To change the rear-loaded paper, open the top cover and the rear flap.)

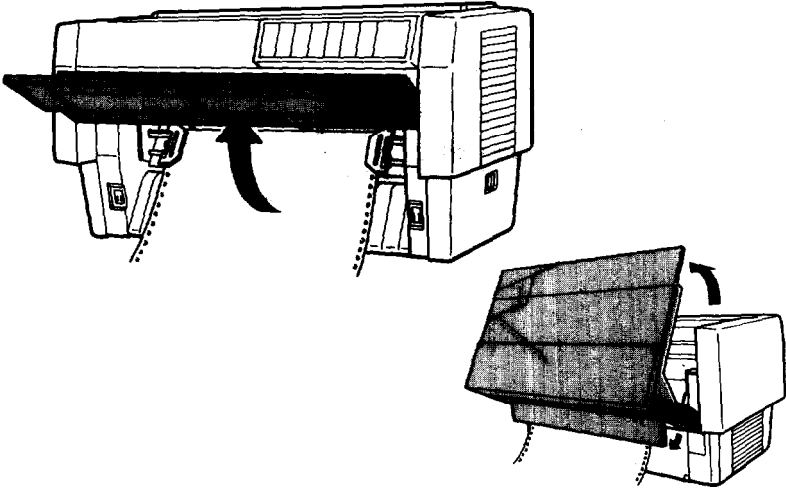

5. Open the sprocket covers and remove the paper from the tractor.

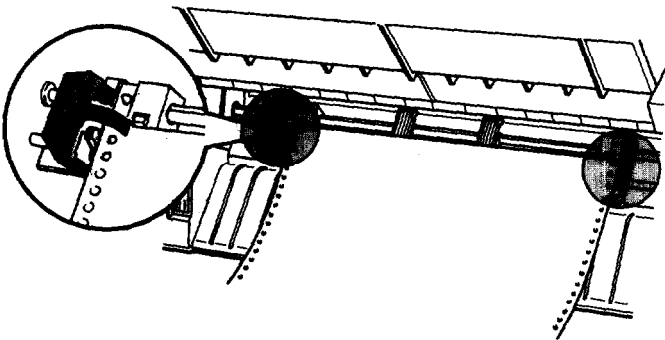

6. Load the new paper onto the front tractor as described in the section on loading paper onto the front tractor in this chapter. (If you are loading paper onto the rear tractor, see the section on loading paper onto that tractor.)

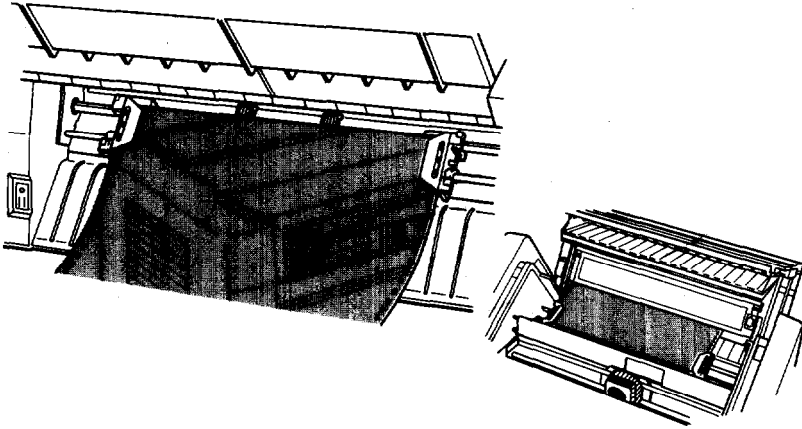

7. Close the front cover (or close the top cover and the rear flap).

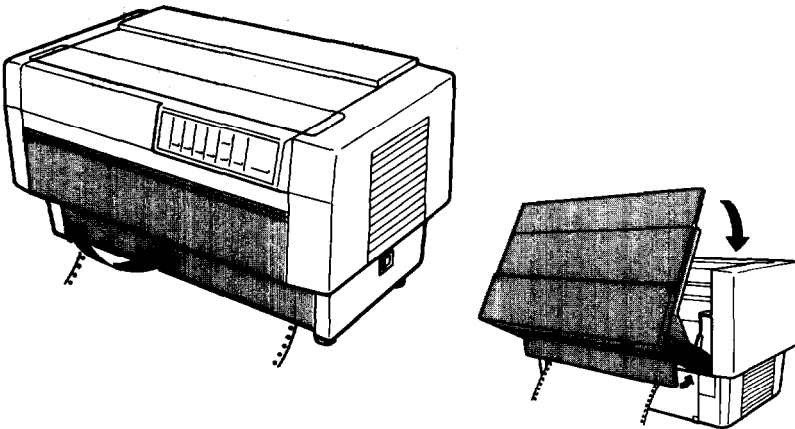

Changing the Paper

8. Press the **FRONT/REAR** button to switch to the front (or rear) tractor and load the paper to the top of form position. Then press the **ON LINE** button -to -put the printer on line so it is ready to print.

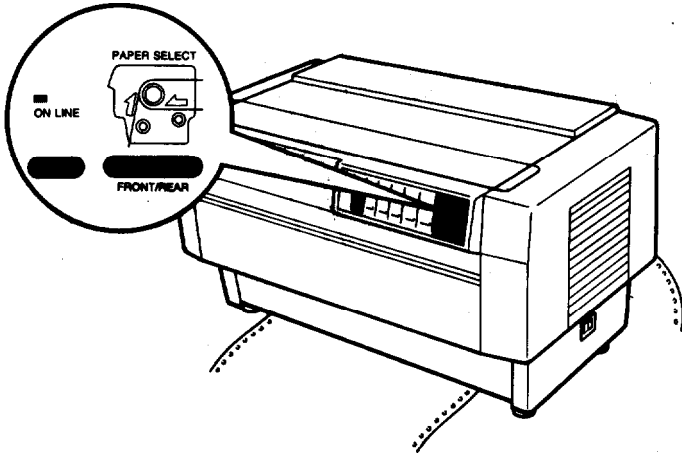

Note: If you open the top cover while the DFX is printing, the printer beeps four times, goes off line, and stops printing. To resume printing, close the top cover and press the **ON LINE** button.

Printing on Special Paper

The DFX-8000 can print on various types of paper, including multi-part forms and labels. It can also handle a variety of paper thicknesses, from thin paper to six-part forms. The printer automatically adjusts to the thickness and width of your paper.

When you print on multi-part forms and labels, the positioning of your text on the page can be critical. For more information on aligning your text, see the sections on adjusting the top of form and printing positions in Chapter 3. You should also check both your printer and your software page length settings before you load labels or forms. See the section on page length in Chapter 3.

If you are using labels or preprinted or multi-part forms, you may want to use the optional pull tractor. See Chapter 5.



WARNING: When printing on multi-part forms or labels, make sure that your printing stays within the printable area of the paper to prevent damage to the print head. For more information on the printable area, see page 8-6.

Copy mode

If the printing on the last pages of your multi-part forms is too faint, you can use the DFX-8000's copy mode to print clearer, darker characters on each page. In copy mode, which is available only for draft, not NLQ, the DFX-8000 prints at half the normal speed.

To select or cancel copy mode, press the **FORM FEED/COPY** button when the **ON LINE** light is on. When you select copy mode, the printer beeps twice; when you cancel copy mode, the printer beeps once.

Multi-part forms

You can use continuous multi-part forms with up to four sheets, including the **original**, on the rear tractor. On the front tractor, you can use forms with up **to** six sheets.

Be sure to use multi-part forms that meet the requirements listed in the section on paper in Chapter 8.



WARNING: Never use multi-part forms **that** have metal staples.

You load continuous **multi-part** forms the same way as you load any other type of continuous paper. Before loading multi-part forms, make sure that the '**paper** has a clean straight edge and does not separate or tear **apart**. See the sections on loading paper earlier in this chapter.

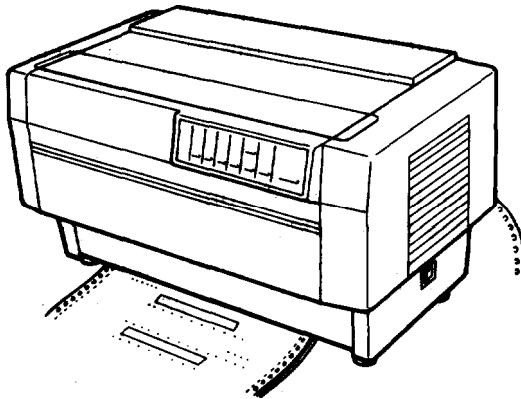

When you use the paper memory feature described in Chapter 3, the DFX-8000 can print on multi-part forms that vary in thickness, such as forms with labels on them or forms that overlap slightly where they **are glued** together. These forms are thicker in the label area and in the places where they overlap and are joined together, as shown below.

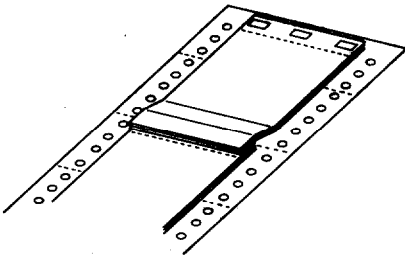

overlapping multi-part forms

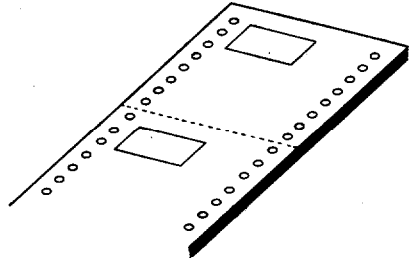

multi-part forms with labels



CAUTION: Be sure to use the paper memory feature before you print on multi-part forms that **vary** in thickness. See Chapter 3 for instructions.

When you print on these forms, make sure that the printing fits within the printable area and the top of form position is set properly. The printable area is shown in Chapter 8.

Labels

When using labels, always choose the type mounted on a continuous backing sheet with sprocket holes for use with a tractor. Labels should be used in the front tractor only. You load labels the same way that you load continuous paper. See the section on loading paper onto the front tractor earlier in this chapter.



WARNING: Never use the **TEAR OFF**, **FRONT/REAR**, or reverse-feeding (bottom) **MICRO FEED** button when labels are loaded in the printer. Labels must never be fed backward through the printer because they can easily come off the backing and jam the printer.

Although you must never feed labels backward through the printer, you can still use the DFX-8000's automatic paper handling features if you follow these precautions:

- Instead of using the **TEAR OFF** button to remove printed labels, take the printer off line and press the **FORM FEED** or **LINE FEED** button until the last printed label is at the point where you can tear it off easily.
- Before using the **FRONT/REAR** button to **switch** tractors, or change paper, remove the entire supply of labels. To remove labels, always tear off the fresh supply at a perforation below the tractor and then press the **FORM FEED** or **LINE FEED** button to eject the remaining labels.
- When you adjust the top of form or printing position, use only the forward-feeding (top) **MICRO FEED** button.

Before you print a large number of labels, print only one page of labels to make sure all the text is printed within the label area.

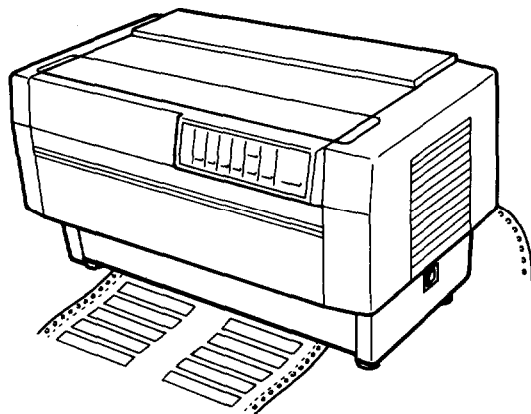

WARNING: Since labels are especially sensitive to extreme temperature and humidity, always use them under normal operating conditions.

Chapter 3

Using the Printer

Operating the Control Panel	3-2
Lights	3-2
Buttons	3-4
Other control panel features.....	3-6
Setting the DIP Switches	3-7
Changing a DIP switch setting.....	3-7
The DIP switch tables.....	3-10
The DIP switch functions	3-14
Page Length	3-17
Skip Over Perforation	3-18
Using the Paper Memory Feature	3-20
Saving paper format and thickness information	3-21
Loading paper format from memory.....	3-31
Adjusting the Top of Form Position	3-33
Adjusting the Printing Position.....	3-37
Using Short Tear-Off.....	3-40
Selecting Typestyles	3-43
Character fonts.....	3-43
Character spacing	3-45
Condensed mode	3-46
Selecting an International Character Set	3-47
Choosing a Character Table	3-49
Data Dump Mode	3-51

Operating the Control Panel

The DFX-8000's control panel gives you access to several powerful features. The control panel buttons let you control paper loading, primer settings, and more. The control panel indicator lights give you status information such as which mode the printer is in, which tractor is loaded with paper, and which tractor is ready to print. The following sections describe the functions of the control panel's lights and buttons.

The indicator lights on the control panel let you check the current status of the printer. Below is an illustration of the control panel lights and a description of their functions.

Lights

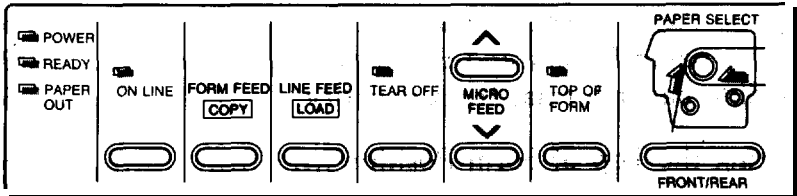

POWER (green)

On when the power switch is on and **power is supplied** to the printer.

READY (green)

On when the printer is on line and ready to receive data from your computer. This light flickers during printing.

PAPER OUT (red)

On when the printer is out of paper. This light goes on whenever there is **no** paper positioned behind the print head, even if there, is paper loaded on the tractors in the standby position. (The printer also beeps when it is out of paper.)

ON LINE (green)

On when the printer is on line and ready to receive and print data from the computer, Also, when the print head overheats, the **ON LINE** light blinks. The printer stops printing, waits several minutes while the print head cools, and then resumes printing.

TEAR OFF (green)

On when the printer is in tear-off mode.

TOP OF FORM (green)

On when the printer is in top of form mode. **When** this light blinks, you can adjust the loading and top of form positions.

PAPER SELECT (red/green)

The front tractor arrow goes on when the front tractor is selected. The rear tractor arrow goes on when the rear **tractor** is selected. The light is green **when paper** is loaded, even if **the** paper is in the standby position, and red when the tractor is completely out of paper.

Operating the Control Panel

Buttons

The control panel buttons let you perform printer operations quickly and easily. Below is an **illustration** of the control panel buttons and a description of their functions.

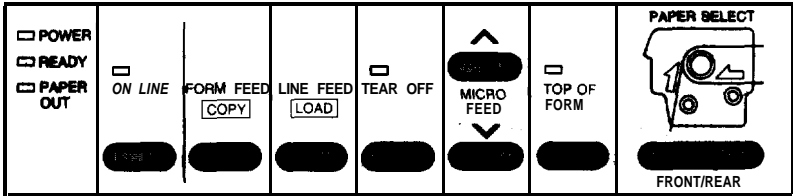

ON LINE

This button controls the printer's on line status. Press this button to put the printer on line or take it off line. When the printer is on line, the **ON LINE** light is on and the printer can receive and print data from the computer.

When the printer is in top of form mode, you can press the **ON LINE** button to exit the mode without setting a new top of form position. You can **also** press the **ON LINE** button to **exit** tear-off mode. See the sections on **adjusting** the top of form position and using short tear-off in this chapter.

FORM FEED/COPY

When the printer is off line, press this button to advance the paper to the top of the next page. To adjust the position the paper is fed to, see the section on adjusting the top of form position in this chapter. When the printer is on line, press this button to select or cancel copy mode. See the section on printing on special paper in Chapter 2 for more information.

LINE FEED/LOAD

When the printer is off line, you use this button to load paper or to advance the paper after you load it. To advance the paper one line, press this button once. To advance the paper continuously, hold down the button.

TEAR OFF

The TEAR OFF button feeds the paper to the printer's tear-off edge so you can tear off your document without losing the paper. normally lost between printing jobs. To use this feature, take the printer off line after your document **finishes** printing **and** press the **TEAR OFF** button. The printer feeds the paper to the printer's tear-off edge. After you tear off the document, press the **TEAR OFF** or **ON LINE** button to feed the paper back to the top of form position.

If the perforation of **your** paper does not align exactly with the printer's tear-off edge, you **can** use the **MICRO FEED** buttons to adjust the tear-off position. See the section on using short tear-off in this chapter.



WARNING Never use the **TEAR OFF** button with labels. Press the **FORM FEED** or **LINE FEED** button instead to feed the **printed** labels to a point where you can tear them off.

MICRO FEED

When the printer is off line, the **two MICRO FEED** buttons advance or reverse the loaded paper in 1/216th-inch increments. You can use these buttons to adjust the **paper** memory, top of form, loading, printing, and tear-off positions. For more information, see the sections on using the paper memory and short tear-off features and adjusting the top of form and printing positions in this chapter.

TOP OF FORM

When the printer is off line, press this button to enter or exit top of form mode. You can also use this button to enter paper memory settings. For more information, see the sections on adjusting the top of form position and using the paper memory feature in this chapter.

FRONT/REAR

When the printer is off line, press this button to select the front or rear tractor. If **you** have been using paper loaded on one tractor, first remove the printed output before switching to the other tractor. When you switch tractors, the printer feeds the paper that is already loaded backward to the standby position and loads paper on the newly selected tractor.



WARNING: Never use the FRONT/REAR button when labels are loaded in the printer. Also, be sure to remove any printed documents before switching tractors. Never feed more than one page backward through the printer.

Other control panel features

The control panel also gives you **access** to several special functions.

Self test: You can run the self test to check whether your printer operates properly. The self test prints the current DIP switch **settings and the** characters in the printer's ROM (Read Only Memory). Your printer offers both draft and NLQ self tests. To start the self test, hold down the **LINE FEED** or **FORM FEED** button and turn on the printer. See the section on running the self test in Chapter **1** for more information.

Data dump: To enter data dump mode, hold down the **LINE FEED** and **FORM FEED** buttons and turn on the printer. This feature prints the codes that are sent **to the** printer so that advanced users can determine the cause of communication problems between the computer and printer. See the section on data dump mode in this chapter for more information.

Setting the DIP Switches

The DFX-8000 has three sets of DIP (Dual Inline Package) switches located under a small cover below the front tractor. By changing the settings of these switches, you can control various printer features, such as the character set, the page length, and the printing speed. The DIP switch tables starting on page 3-11 describe the functions of the DIP switches.

Because the factory (default) settings are designed to accommodate the needs of most users, you probably won't change DIP switch settings very often. When you do need to set a DIP switch, follow the steps below. Be sure to turn off the printer before you start and turn it on again when you are done. New DIP switch settings take effect only after you turn on or reset the printer.

Changing a DIP switch setting

To change a DIP switch setting, follow these steps:

1. Turn off the printer.

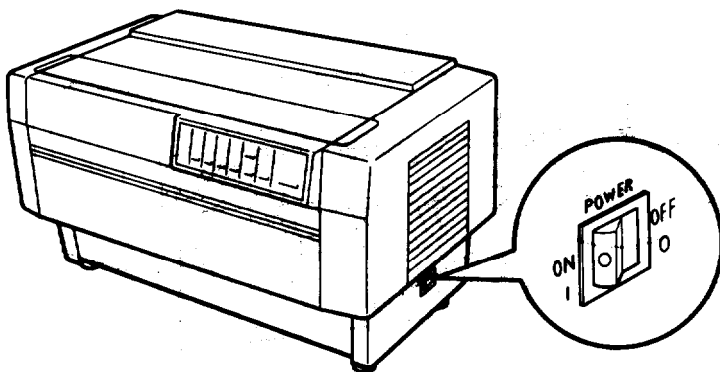

Setting the *DIP Switches*

2. Open the front cover. If there is paper loaded on the front tractor, remove it.

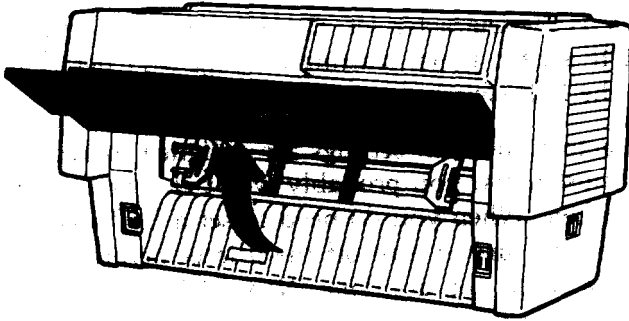

3. Open the DIP switch cover as shown below.

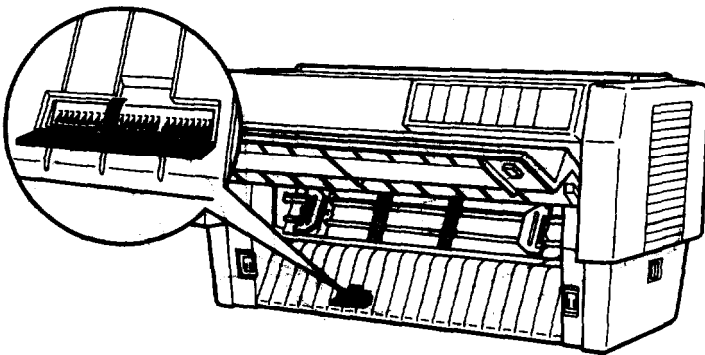

4. Use a pointed instrument, such as the tip of a pen or pencil; to turn a switch on or off. A DIP switch is on when it is up, and off when it is down.

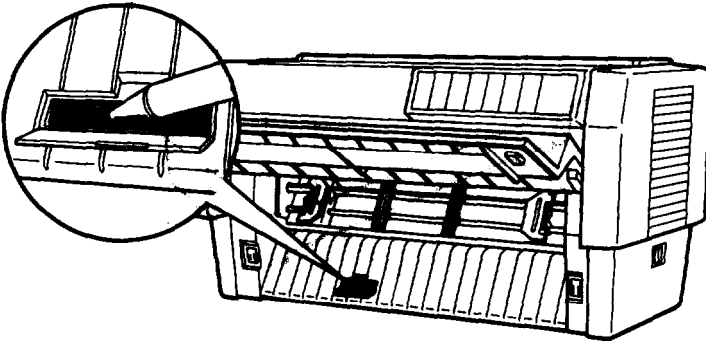

CAUTION: Always make sure the printer is turned off before you change the DIP switch **settings**.

5. Close the DIP switch cover.

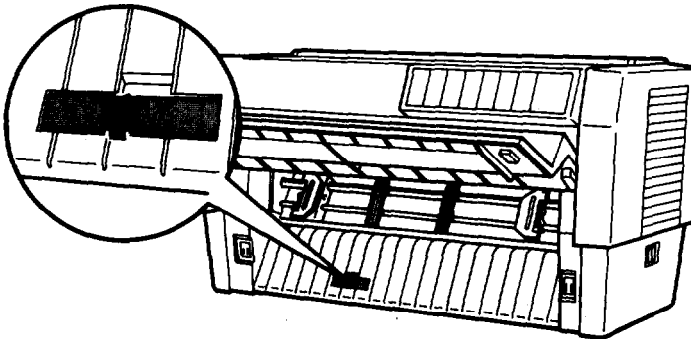

Setting the *DIP Switches*

6. Replace the paper and close the front cover,

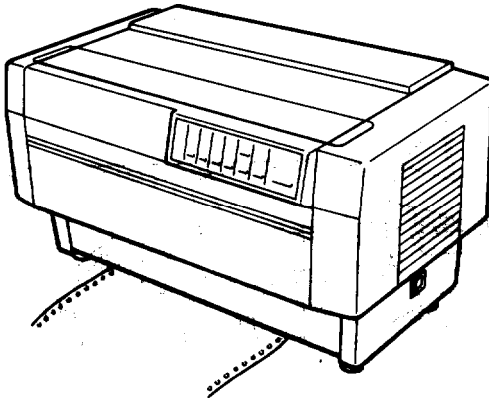

The new DIP switch settings take effect when you turn on the printer.

The DIP switch tables

The tables on the next page describe the functions of the DIP switches. The shaded boxes show the default or factory settings. See the page numbers listed on the right for more information about each feature.

DIP Switch 1

SW	Description	ON	OFF	Page
1-1	Condensed mode on/off	Condensed		3-46
1-2	Slashed zero on/off	Slashed		3-14
1-3	Character table* (in Epson ESC/P mode)	Graphics	Italics	3-49
1-4	Printer mode**	IBM emulation		3-14
1-5	NLQ or draft mode	NLQ		3-43
1-6	International character set (available only in Epson ESC/P mode)	See the international character set table on the next page.		3-47
1-7				
1-8				

DIP Switch 2

SW	Description	ON	OFF	Page
2-1	Default character set (in Epson ESC/P mode)	User-defined		3-14
2-2	Draft printing speed	Normal		3-14
2-3	Bit length for serial interface	7 bits		3-15
2-4	Auto line feed	ON		3-15
2-5	Interface type/parity	See table on page 3-13.		3-15
2-6				
2-7	Baud rate	See table on page 3-13.		3-16
2-8				

. The default setting for DIP switch 1-3 varies depending on the country.

** When DIP switch 1-4 is on and the printer is in IBM emulation mode, the functions of DIP switches 1-3, 1-6, 1-7, 1-8 and 2-1 differ from those listed in this table. See the table on page 3-13 for their functions in IBM emulation mode.

DIP Switch 3

SW	Description	ON	OFF	Page
3-1	Input buffer	Invalid		3-16
3-2	Page length	12 inches	11 inches	3-17
3-3	1-inch skip over perforation	ON		3-18
3-4	Paper memory	Memory 2		3-20
3-5	Overlapping multi-part forms	Valid		3-20
3-6	Multi-part forms with labels	Valid		3-20
3-7	Skip over binding	ON		3-16
3-8	Handshaking protocol	X-on/X-off		3-16

- The default setting for DIP switch 3-2 varies depending on the country.

International character set

Country	SW 1-6*	SW 1-7*	SW 1-8*
USA	ON	ON	ON
France	ON	ON	OFF
Germany	ON	OFF	ON
United Kingdom	ON	OFF	OFF
Denmark	OFF	ON	ON
Sweden	OFF	ON	OFF
Italy	OFF	OFF	ON
Spain	OFF	OFF	OFF

- * The default settings for these DIP switches vary depending on the country.

Interface/Parity selection

Interface/Parity	SW 2-5	SW 2-6
Serial/odd	OFF	ON
Serial/even	ON	OFF
Serial/none	ON	ON

Baud rate selection

Baud rate	SW 2-7	SW 2-8
9600 bps	OFF	ON
1200 bps	ON	OFF
300 bps	ON	ON

When you select IBM emulation mode by turning on DIP switch 1-4, DIP switches 1-3, 1-6, 1-7, 1-8, and 2-1 function differently than they do in Epson ESC/P mode. The tables below show the functions of these switches in IBM emulation mode.

DIP switch functions in IBM emulation mode

SW	Description	ON	OFF
1-3	Automatic carriage return	OFF	ON
1-6	Default character table	See table below.	
1-7			
1-8			
2-1	FF command at the top of form position	Invalid	Valid

IBM emulation mode character tables

Default character table	SW 1-6	SW 1-7	SW 1-8
Table 1 •	On	On	On
Table 2*	Table 2 is selected when any one of these switches is turned off.		

- The Appendix shows the characters included in each character table.

The DIP switch functions

This section describes the different **features** you can control with the printer's **DIP switches**.

Slashed zero

When DIP switch **1-2** is on, the printer prints slashed **zeros(0)**. When the DIP switch is off, the printer prints open zeros (**0**). This feature is useful for clearly distinguishing between uppercase 0 and zero when printing documents such as program lists.

Printer mode

When DIP switch **1-4** is on, the printer operates in IBM emulation mode. When the DIP switch is off, the printer operates in Epson ESC/P mode. The functions of DIP switches **1-3, 1-6, 1-7, 1-8,** and **2-1 in IBM emulation** mode differ from their functions in Epson ESC/P mode. The tables on the previous page describe the special functions of these DIP switches in IBM emulation mode.

Default character set

When DIP switch **2-1** is on, the user-defined character set is the default. User-defined characters **are maintained** in the printer's memory even when the power is turned off, so you can select the user-defined character set simply by turning on this DIP switch. However, when the switch is on, you cannot define new **user-defined characters**. The setting of this DIP switch takes effect only if DIP switch **1-4** is set for Epson ESC/P mode. See Chapter 4 for more information on user-defined characters.

Draft printing speed

When DIP switch **2-2** is off, high-speed draft mode is selected. When the switch is on, normal draft mode is selected. This switch only affects the printer if DIP switch **1-5** is set for draft mode (turned off) or if draft mode is selected through your software. In high-speed draft mode, the DFX-8000 can print up to **1066** characters per second at **10** cpi (characters per inch). In normal

draft mode, the DFX-8000 prints up to 800 characters per second at 10 cpi. Normal draft mode produces characters that are more fully formed than characters produced in high-speed draft mode.

Note: High-speed draft mode is available only for 10 cpi printing. Also, underlining and double-wide are the only print enhancements that work in high-speed draft mode. If you use a feature such as **emphasized**, **double-strike**, or italics in **high-speed** draft mode, the printer temporarily slows to the normal draft speed until the feature is turned off. This allows you to use any print enhancement without cancelling **high-speed draft mode**.

Bit length for serial interface

When DIP switch 2-3 is on, the bit length for the serial interface is set to 7 bits. When the DIP switch is off, the bit length is set to 8 bits.

Auto line feed

When DIP, switch 2-4 is on, the printer adds a line feed (LF) command to every carriage return (**CR**) code sent by the application program. When the switch is off, line feeds occur only **when the** software sends line feed commands to the printer. Since most computers and application programs automatically add line feeds to carriage returns, you should use this feature only if your text is printing all on one line.

Interface parity

If your computer is set up for serial communication, you need to change DIP switches 2-5 and 2-6 so that your printer and computer can communicate properly. These DIP switches control the interface type and parity. (You may also need to select a different baud rate as described in the next section.)

The table on page 3-13 shows the DIP switch settings for a parallel interface and a **serial** interface with odd, even, or no parity. If you

Setting the DIP Switches

don't know what type of interface your computer requires, check your computer manual. Also check your computer manual to make sure your computer and printer have **the same parity settings**.

Baud rate

If your computer is set up for serial communication, you may need to set the baud rate in addition to selecting serial interface and setting the parity. **The baud rate** is the rate at which the printer receives data from the computer.

DIP switches 2-7 and 2-8 control the baud rate. The table on page 3-13 shows the DIP switch settings for the printer's four baud rate settings. Check your computer or application program manual for the correct baud rate setting. Your computer and printer should always be set to the same baud rate.

Input buffer

The printer's input buffer provides additional memory to free up the computer while you print large amounts of text or graphics. The input buffer is enabled when DIP switch **3-1** is off. To disable the buffer, turn on DIP switch **3-1**.

Skip over binding

When DIP switch 3-7 is on, the print head avoids the binding area along the right and left edges of multi-part forms during paper feeding. Using this feature helps avoid paper jams when you use multi-part forms.

Handshaking protocol

If your computer is set up for serial communication, you may need to select the handshaking protocol.

When DIP switch 3-8 is on, the printer uses X-on/X-off handshaking protocol. When the switch is off, the printer uses DTR (Data Terminal Ready) handshaking protocol.

Page Length

When DIP switch 3-2 is off, the page length is set to **11 inches** (27.94 cm). When the DIP switch is on, the page length is 12 inches (30.48 cm). Be sure to set the page length to match the paper you plan to use.

Other page lengths can be set with the ESC C and ESC CO commands. See the Command Summary in Chapter 9.

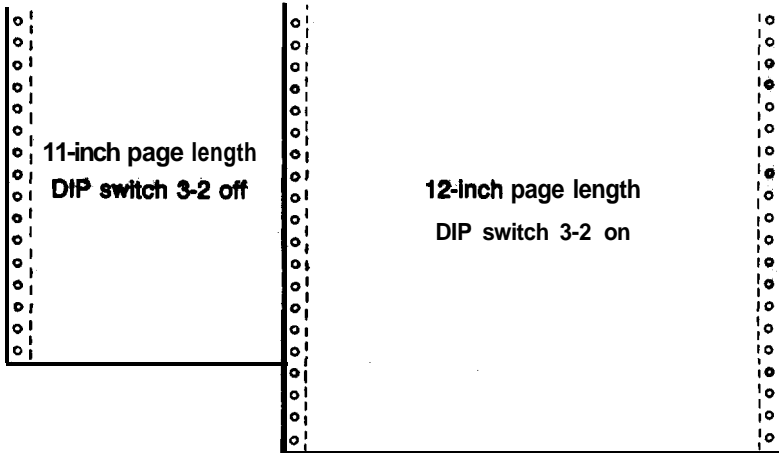

Skip Over Perforation

When DIP switch 3-3 is **on**, the printer inserts a one-inch margin between the last line **printed on one page** and the first line printed on the next **page**. You can change the margin size with the ESC N command. See the Command Summary in Chapter 9.

By adjusting your loading position, you can get half the margin at the bottom of one page and half at the top of the next page, as shown here:

skip over perforation off (DIP switch 3-3 off)

```
● 0123456789 : ; <=> ? @ ABCDEFGHI JKLMNOPQRSTU
123456789 : ; <=> ? @ ABCDEFGHI JKLMNOPQRSTUV
23456789 : ; <=> ? @ ABCDEFGHI JKLMNOPQRSTUVW
● 3456789 : ; <=> ? @ ABCDEFGHI JKLMNOPQRSTUVWX
456789 : ; <=> ? @ ABCDEFGHI JKLMNOPQRSTUVWXY
-----
● 56789 : ; <=> ? @ ABCDEFGHI JKLMNOPQRSTUVWXYZ
6789 : ; <=> ? @ ABCDEFGHI JKLMNOPQRSTUVWXYZ [
789 : ; <=> ? @ ABCDEFGHI JKLMNOPQRSTUVWXYZ [ \
89 : ; <=> ? @ ABCDEFGHI JKLMNOPQRSTUVWXYZ [ \ ]
● 9 : ; <=> ? @ ABCDEFGHI JKLMNOPQRSTUVWXYZ [ \ ] ^
```

skip over perforation on (DIP switch 3-3 on)

```
● 0123456789 : ; <=> ? @ ABCDEFGHI JKLMNOPQRSTU
123456789 : ; <=> ? @ ABCDEFGHI JKLMNOPQRSTUV
23456789 : ; <=> ? @ ABCDEFGHI JKLMNOPQRSTUVW
●
-----
●
● 3456789 : ; <=> ? @ ABCDEFGHI JKLMNOPQRSTUVWX
456789 : ; <=> ? @ ABCDEFGHI JKLMNOPQRSTUVWXY
56789 : ; <=> ? @ ABCDEFGHI JKLMNOPQRSTUVWXYZ
```

Note: Because most application programs insert their own top and bottom margins, you should use the skip over perforation feature only if your program does not provide them.

Using the Paper Memory Feature

When you use multi-part forms that vary in thickness, use the paper memory feature so that the printer can compensate for the variations to produce high quality printing. Multi-part forms that vary in thickness include forms that have labels on them and forms that overlap slightly where they are glued together. Examples of these forms are shown below.

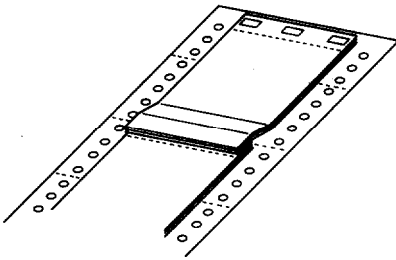

overlapping multi-part forms

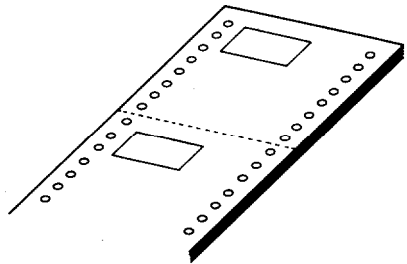

multi-part forms with labels

You can save paper format and thickness information for up to two multi-part forms on the printer's paper memory areas. When you tell the printer it is using a certain form, the printer automatically adjusts the gap between the print head and the platen to provide maximum printing quality on that particular form. The paper memory feature is available only for forms loaded on the front tractor.



WARNING: When you use multi-part forms that vary in thickness, do not press the **TEAR OFF**, **FRONT/REAR**, or reverse-feeding (bottom) **MICRO FEED** button or a paper jam may result. To remove these forms, tear off the fresh supply at a perforation below the front tractor, take the printer off line, and press the **FORM FEED** or **LINE FEED** button to eject the remaining forms.

Note: To use the paper memory feature, you need to reset some DIP switches. See the section on changing a DIP switch setting in this chapter for instructions on **how** to set a DIP switch.

Saving paper format and thickness information

The following sections describe how to save paper format and thickness information for different types of multi-part forms.

Saving information for overlapping multi-part forms

To save paper format and thickness information for multi-part forms **that overlap** slightly where they are joined together, follow the steps below.

1. Turn off the printer.
2. Use DIP switch 3-4 to select the memory area **where you want** the printer to store the paper format and thickness information. Memory area **1** is selected when DIP switch **3-4** is off. (This is the printer's default setting.) To select memory area 2, turn on the switch.

Paper memory	DIP SW 3-4
Memory 1	OFF
Memory 2	ON

Using the Paper Memory Feature

Note: Be sure to remember or write down the memory area you use for **each form**.

- Use DIP switch 3-2 to set the page length. If you plan to use forms of a different page length, use software commands to set the page length after you finish saving the overlapping form information.

Page length	DIP SW 3-2
11 inches	OFF
12 inches	ON

- Turn on DIP **switch 3-5** and turn off DIP **switch 3-6**. **This tells** the printer you want to save information for multi-part forms that overlap slightly where they are joined together.

Overlapping multi-part forms	DIP SW 3-5
Invalid	OFF

Multi-part forms with labels	DIP SW 3-6
Valid	ON

Note: Whenever DIP switch 3-5 is on, the skip over perforation feature is valid, **regardless** of DIP switch 3-3's setting.

5. Hold down both MICRO FEED buttons and turn on the printer. The printer saves the overlapping form information in the memory **area you selected**. **When the information is saved, the printer beeps and goes off line.**

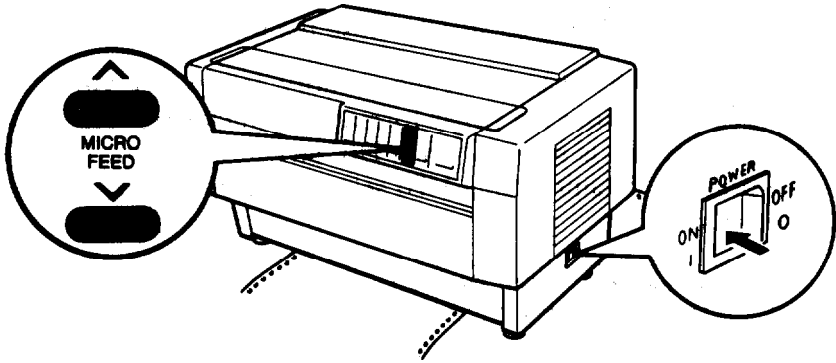

You can print on these forms even if you turn the printer off and then back on. To use other types of paper, see the section on loading paper format information from memory later in this chapter.



CAUTION: When you print on these forms, make sure that the printing fits within the printable area and the top of form position is set properly. The printable area is shown in Chapter 8.

Using the Paper Memory Feature

Saving information for multi-part forms with labels

To save paper format and thickness information for multi-part forms with labels on them, follow the steps below.

1. Load the forms with labels onto the front tractor. (See the section on loading paper onto the front tractor in Chapter 2.)
2. Turn off the printer. Be sure to close the top cover.
3. Use DIP switch **3-4** to select the memory area where you want the printer to store the paper format and thickness information. Memory area **1** is selected when DIP switch 3-4 is off. (This is the printer's default setting.) To select memory area **2**, turn on the switch.

Paper memory	DIP SW 3-4
Memory 1	OFF
Memory 2	ON

4. Use DIP switch **3-2** to set the page length. If you plan to use forms of a different page length, use software commands to set the page length after you finish saving the form's information.

Page length	DIP SW 3-2
11 inches	OFF
12 inches	ON

5. Turn off DIP switch **3-5** and turn on DIP switch **3-6**. This tells the printer you want to save information for multi-part forms with labels on them.

Overlapping multi-part forms	DIP SW 3-5
Valid	ON

Multi-part forms with labels	DIP SW 3-6
Invalid	OFF

6. Hold down both **MICRO FEED** buttons and turn on the printer. The printer beeps. Press the **LINE FEED/LOAD** button to load the forms. The printer loads and checks the forms. When the check is finished, the printer beeps continuously until you open the top cover in **the** next step.

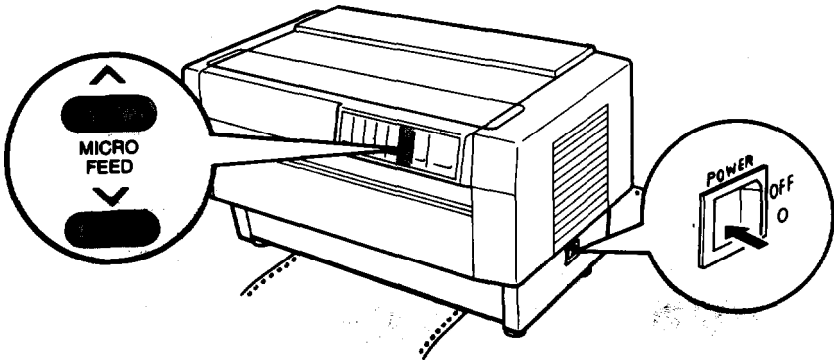

CAUTION: Do not go on to the next step before **the** printer beeps to tell you the check is finished.

7. Open the top cover.

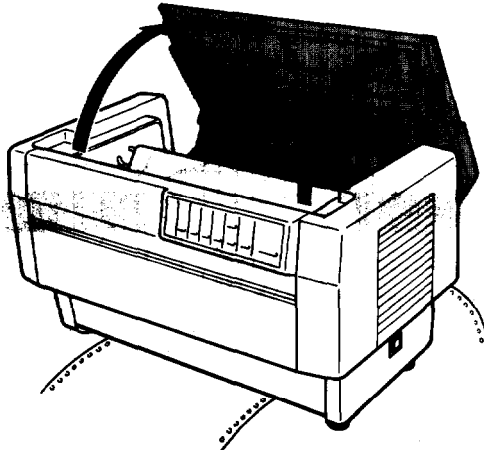



CAUTION: Complete all the following steps before attempting any other operations, such as adjusting the top of form position.

8. Use the **MICRO FEED** buttons to adjust your paper's position so that the top edge of the label is aligned with the horizontal red line on the clear plastic ribbon mask.

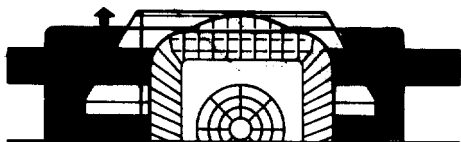

9. Move the print head by hand to align the vertical red line on the ribbon mask with the left edge of the label. Now the intersection of the red lines on the ribbon mask should be in the upper left corner of the label.

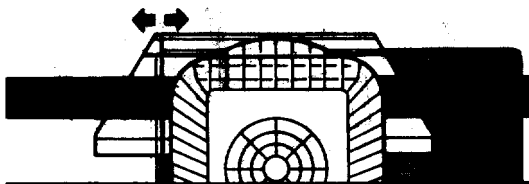

10. Press the **TOP OF FORM** button. The printer beeps once.

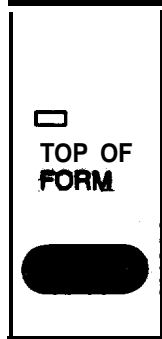

11. Use the **MICRO FEED** buttons to adjust your paper's **position** so that the bottom edge of the label is aligned with the horizontal red line on the ribbon mask.

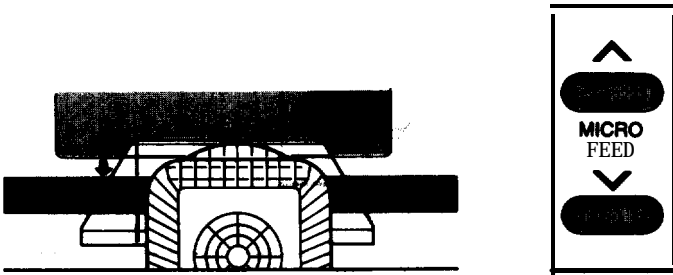

Using the Paper Memory Feature

12. Move the print head by hand to align the vertical red line on the ribbon mask with the right edge of the label. Now the intersection of the red lines on the ribbon mask should be in the lower right corner of the label.

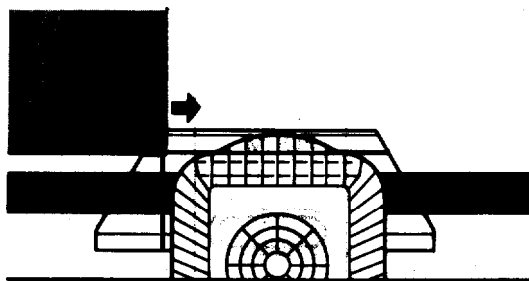

13. Press the TOP OF FORM button. The printer beeps twice. This tells the printer the label's location on the form.

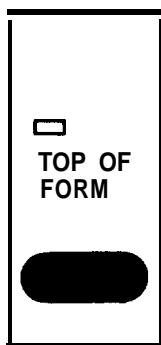

Note: If the label's location is still not correct, repeat the above procedure from step 8 on page 3-26. Be sure that you set both the upper left and lower right corners of the label when performing this procedure.

14. Close the top cover. The printer checks your paper's thickness at various points and saves this information. (This takes the printer a certain amount time to complete.) When it is done, the printer beeps and advances the form one page. The printer then goes off line.

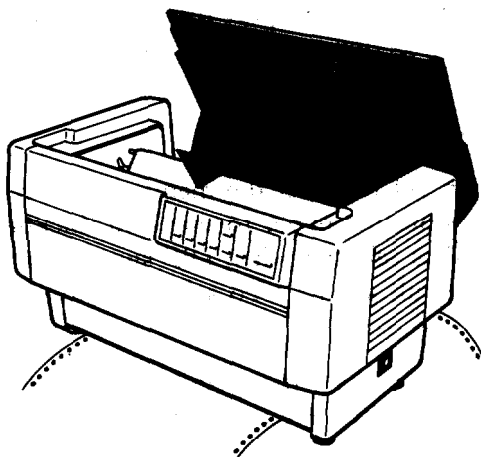

Notes:

- If you close the top cover before setting the label's location, the printer beeps several times to let you know an error **has** occurred.
- In step 14, the printer advances the form one page, according to the setting of DIP switch **3-2**. If your form has a different page length, set the correct page length with software commands and adjust the top of form position accordingly.

You can print on these forms even if you turn the printer off and then back on. To use other types of paper, see the section on loading paper format information from memory later in this chapter.



CAUTION: When you print on these forms, make sure that the printing fits within the printable area. The printable area is shown in Chapter 8.

Saving information for overlapping multi-part forms-with labels

To save paper format and thickness information for multi-part forms that overlap slightly and have labels on them, follow the steps below.

1. Load the overlapping multi-part forms with labels onto the front tractor. (See the section on **loading paper** onto the front tractor in Chapter 2.)
2. Turn off the printer.
3. Use DIP switch 3-4 to select the memory area where you want the printer to store the paper format and thickness information. Memory area 1 is selected when DIP switch 3-4 is off. (This is the printer's default setting.) To select memory area 2, turn on the switch.
4. Use DIP switch 3-2 to set the page length. The page length is 11 inches when DIP switch 3-2 is off and 12 inches when the switch is on. If you plan to use forms of a different page length, use software commands to set the page length after you finish saving the form's information.
5. Turn on DIP switches 3-5 and 3-6. This tells the printer you want to save information for multi-part forms that overlap slightly and have labels on them.

Overlapping multi-part forms	DIP SW 3-5
Invalid	OFF

Multi-part forms with labels	DIP SW 3-6
Invalid	OFF

Note: Whenever DIP switch 3-5 is on, the skip over perforation feature is valid, regardless of DIP switch 3-3's setting.

6. Follow steps 6 through 14 on pages 3-25 through 3-29.

Loading paper format information **from memory**

After you save the information for your multi-part forms, you can load the forms you want to use, select the paper memory feature, and start printing. When you select the paper memory feature, the printer loads your form's information from its memory. To select the paper memory feature, follow the steps below.

1. Load the multi-part forms you want to use onto the front tractor.
2. Turn off the printer.
3. Now load the paper format and thickness information for the multi-part forms you want to use.

To load the information from memory area **1**, hold down the top **MICRO FEED** button and turn **on** the printer.

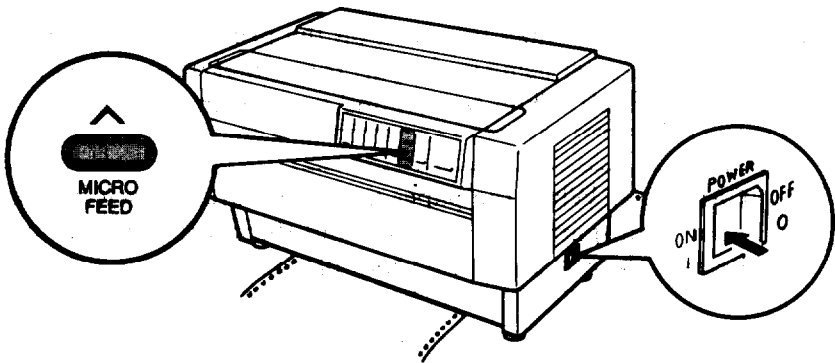

Using the *Paper* Memory *Feature*

To load the information from memory area 2, hold down the bottom **MICRO FEED** button and turn on the printer.

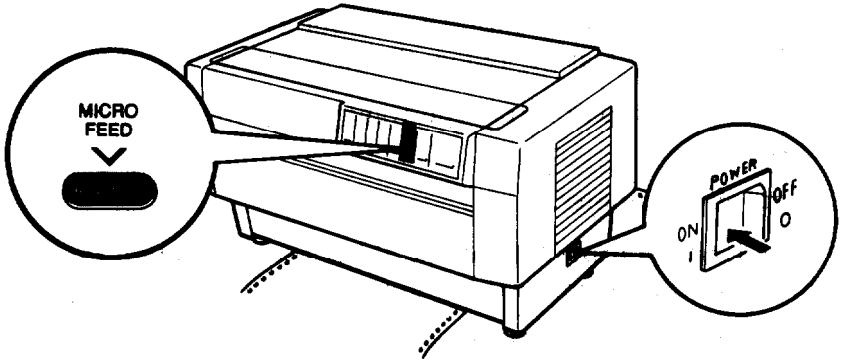

Note: After you load the information, the printer uses this information as the default setting when you turn on the printer. To use regular continuous paper after using multi-part forms that vary in thickness, hold down the **FRONT/REAR** button and turn on the printer.



CAUTION: While the paper memory feature is selected and your multi-part form's format and thickness information is loaded, do not use other types of paper.

Adjusting the Top of Form Position

The top of form position is the position the printer feeds the paper to when it loads the paper or performs a form feed. This position is important because it determines where the printing begins on each page.

If the printing is too high or low on the page, you can reset the top of form position by following the steps below. The printer remembers the **new** top of form position even after the printer is turned off, reset, or initialized. (The printer remembers separate top of form positions for the front and rear tractors.)

To temporarily change the top of form position, you can adjust the position when the printer is not in top of form mode or you change the printing position in the middle of a page as described in the next section. The printer remembers the temporary top of form position until the next time you load paper or switch tractors.

You can set the top of form position, from 0.1 inches (2.6 mm) to 22 inches (558.8 mm) below the top edge of paper. The factory setting is the 0.2 inches (5.8 mm) position below the top edge of paper.



WARNING: When labels are loaded in the printer, do **not** enter top of form mode **as** described in this section. To adjust the top of form position when you are using labels, use only **the** forward-feeding (top) **MICRO FEED** button. Labels must never be fed backward through the printer. See the section on adjusting the printing position in this chapter.



CAUTION: While using the paper memory feature to save the format information about your multi-part forms, do not try to adjust the top of form position.

Adjusting the Top of Form Position

1. Make sure that the printer is tuned on and that it is off line. Also be sure the desired tractor is selected (the **corresponding** tractor arrow should be lit).

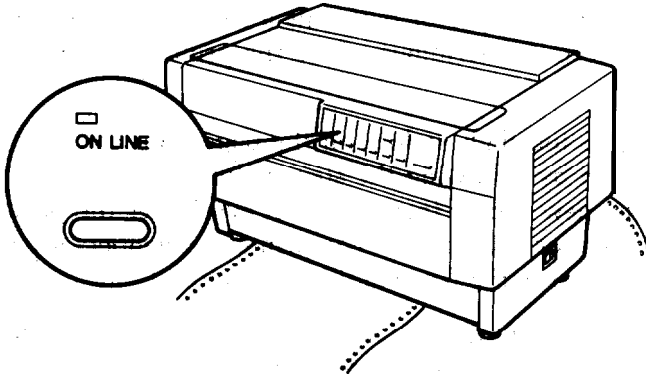

2. Press the TOP OF FORM button to enter top of form mode. The printer beeps, the TOP OF FORM light goes on, and the printer advances the paper slightly.

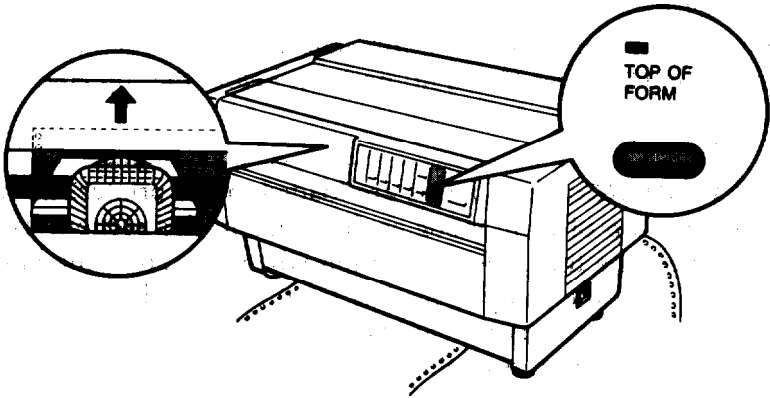

CAUTION: Whenever you press the **TOP OF FORM** button and the **TOP OF FORM** light goes on, the printer sets a new top of form position. If you press the **TOP OF FORM** button by mistake, you can press the **ON LINE** button to cancel the new setting and exit top of form mode,

3. Open the top cover.

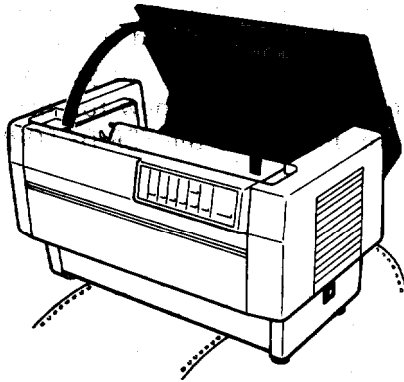

4. On the clear plastic ribbon mask, there is a red line that shows you where the printer will print the bottom edge of your first line of text. This position is based on the first printable line of text. If your software inserts a top margin of five lines, your text will actually be printed five lines below the top of form position. Using the red line as a reference, press the MICRO FEED buttons to feed the paper to the desired top of form position. Press the top or bottom MICRO RED button once to feed the paper forward or backward 1/216th of an inch, or hold down the button to move the paper continuously.

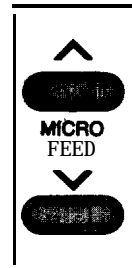
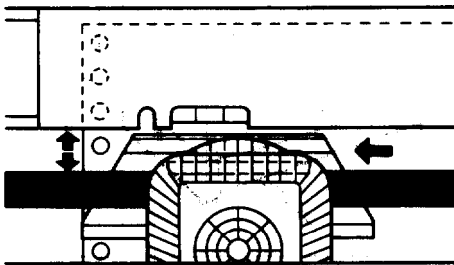

Note: The red line on the ribbon mask shows you where the printer will print your first line of text only when the printer is in top of form mode.

Adjusting the Top Of Form Position

- To exit top of form mode and save your new top of form position, press the **TOP OF FORM** button again. The printer beeps, the **TOP OF FORM** light goes off, and the printer feeds the paper backward to the **printing** position. (If you want to exit top of form mode without saving your new top of form setting, press the **ON LINE** button instead of the **TOP OF FORM** button.) Close the top cover.

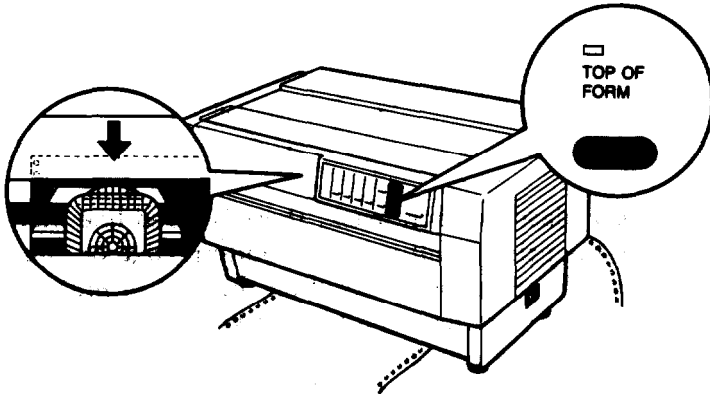

- Press the **ON LINE** button to put the printer on line.

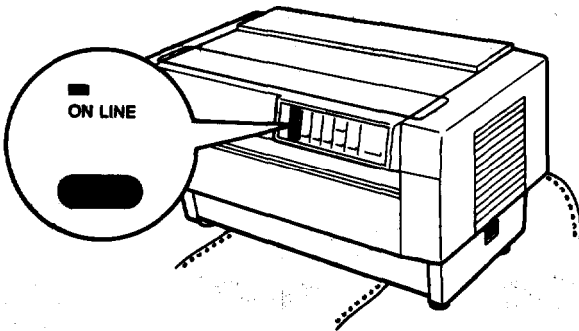

Note: If you enter top of form mode right after loading paper, the **TOP OF FORM** light blinks. While the **TOP OF FORM** light is blinking you can set the loading and top of form positions at the same time.

Adjusting the Printing Position

If you need to adjust the printing position in the middle of a page or document or adjust the top of form position when using labels, follow the steps below.

When you move the printing position, you temporarily change the top of form position by the same amount. -For example, if you adjust the printing in the middle of a page so that it falls a half-inch lower, the next page also begins a half-inch lower. The printer remembers this temporary top of form position until the next time you switch tractors or load paper.

1. Press the **ON LINE** button to take the printer off line.

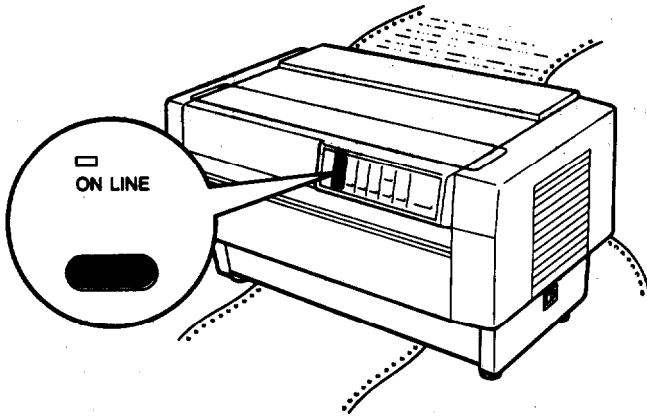

Adjusting the Printing Position

2. Open the top cover.

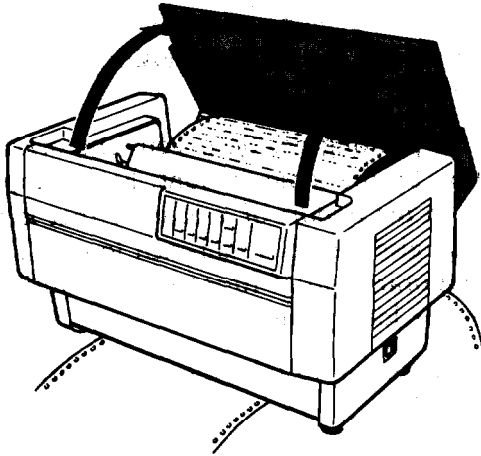

3. Press the top or bottom MICRO FEED button once to feed the paper forward or backward 1/216th of an inch, or hold down the button to move the paper continuously..

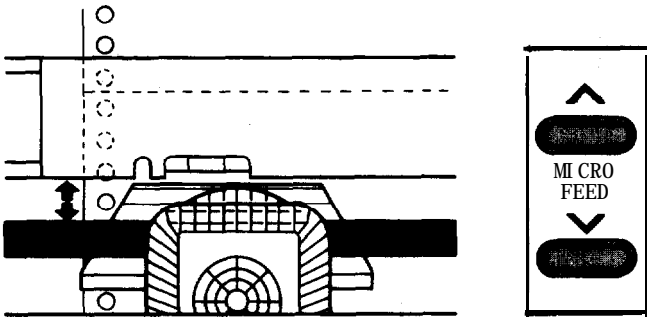

WARNING: If you are using labels, use only the forward-feeding (top) MICRO FEED button.

4. When you are finished, close the top cover and press the **ON LINE** button to put the printer on line.

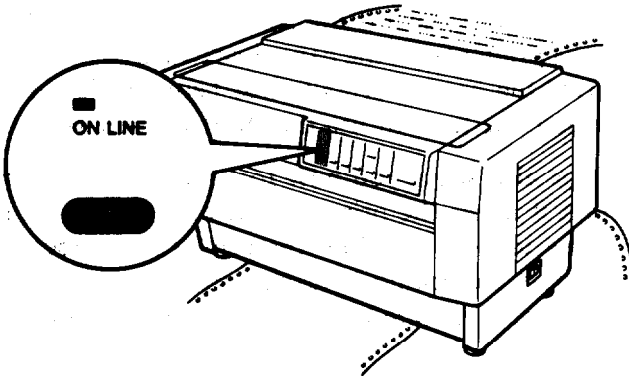

Using Short Tear-Off

When you are finished printing, you can use the short tear-off feature to feed the perforation of your paper to the printer's tear-off edge. Then you can easily tear off the last printed sheet. When you resume printing, the printer feeds the paper backward to the top of form position. This saves the paper normally lost between documents. The steps below describe how to use the short tear-off feature.

The following steps also show you how to adjust the position of the perforation so that it meets the printer's tear-off edge if you need to. If you set a new tear-off position, the printer remembers the new setting even after the printer is turned off, reset, or initialized. (The printer remembers separate tear-off positions for front and rear tractors.)



WARNING: Never use the **TEAR OFF** button with labels, or when the optional pull tractor is installed.

1. Make sure that the printer is turned on and that it is off line. Also be sure the desired tractor is selected (the corresponding tractor arrow should be lit).
2. Open the paper separator cover (the flap on the top part of the printer's top cover). This exposes the printer's tear-off edge.

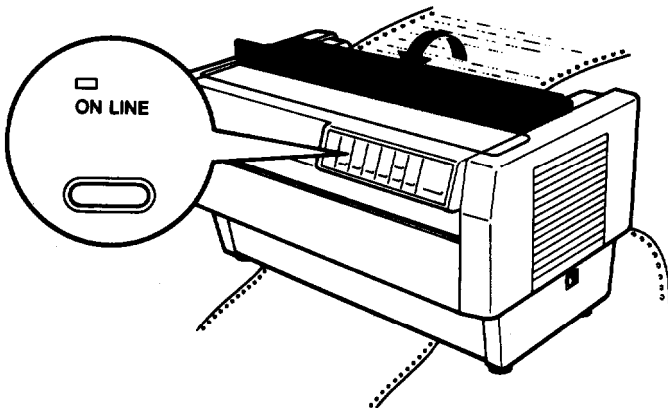

3. Press the TEAR OFF button to enter tear-off mode. The TEAR OFF light goes on and the printer feeds the paper's perforation to the printer's tear-off edge.

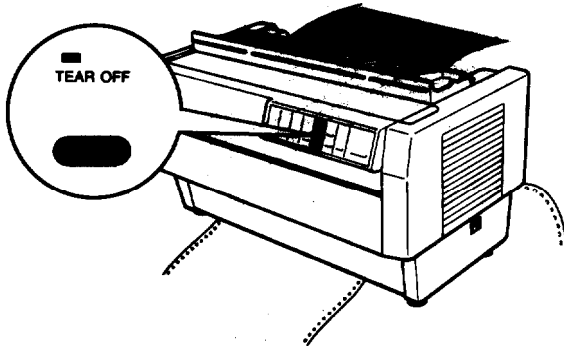

4. If you need to adjust the position of the perforation so that it meets the printer's tear-off edge, use the MICRO FEED buttons. You can press the top or bottom MICRO FEED button once to feed the paper forward or backward $\frac{1}{216}$ th of an inch, or hold down the button to feed the paper continuously.

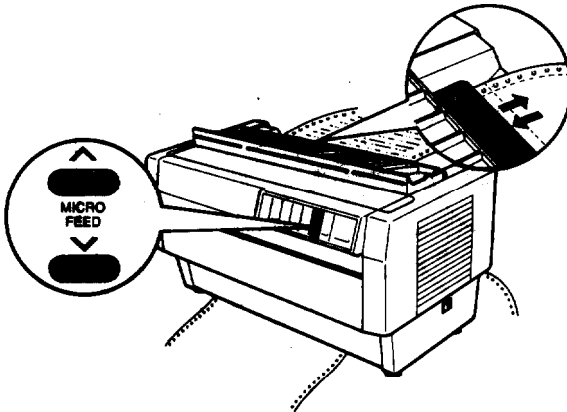

Note: You can reset the tear-off position only when you are in tear-off mode (after you have pressed the TEAR OFF button once and the TEAR OFF light is on).

5. Tear off the page using the **tear-off edge** on the printer's top cover.

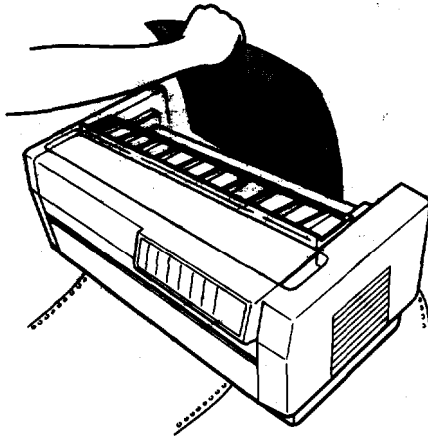

6. Press the **TEAR OFF** button to feed the paper back to the top of form position. Then press the **ON LINE** button to put the printer on line so it is ready to print. (Or instead, just press the **ON LINE** button to feed the **paper** back and put your printer on line at the same time.)

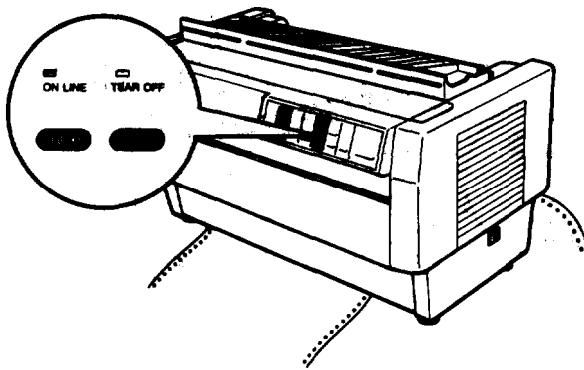

WARNING: Always tear off the printed document before you feed the paper back to the top of form position. Never feed paper backward more than one page.

Selecting Typestyles

You can produce a wide range of typestyles by combining different character fonts, widths, and other enhancements. You can select typestyles using the DIP switches or software commands. For information on the available features, see the section on enhancing your printing in Chapter 4.

Character fonts

The DFX-8000's draft font produces lower-resolution characters with fewer dots per character for high-speed printing. It is ideal for rough drafts and editing work. To select the draft font, turn **off** DIP switch **1-5**. The DFX-8000 can print the draft font at two speeds. The draft font printing speed is high when DIP switch **2-2** is off and normal when the switch is on.

NLQ mode produces high quality text characters at a slower printing speed. The DFX-8000 offers two NLQ fonts, Roman and Sans Serif. To select NLQ mode, turn on DIP switch **1-5**. In Epson ESC/P mode (which is selected when DIP switch **1-4** is off), Roman is the default font selected when DIP switch 1-5 is on. You can select Sans Serif with the software command ESC k. (In IBM emulation mode, Sans Serif is the default font selected **when** DIP switch **1-5** is on.)

The following samples show the characters for each font.

high-speed draft

```
!"#$%&'()*+,-./0123456789:;<=>?@ABCDEFGHIJK  
LMNOPQRSTUVWXYZ[\]^_`abcdefghijklmnopqrstuv  
wxyz{|}~
```

```
We've just seen your excellent ad for  
miniature zebras in a recent back issue of  
Trader's Times. What is the price schedule  
for quantities over one gross?
```

Selecting *Typstyles*

normal draft

!"#\$%&'()*+,-./0123456789:;<=>?@ABCDEFGHIJK
LMNOPQRSTUVWXYZ[\]^_`abcdefghijklmnopqrstuv
wxyz{|}~

We've just seen your excellent ad for miniature zebras in a recent back issue of Trader's Times. What is the price schedule for quantities over one gross?

NLQ Roman

!"#\$%&'()*+,-./0123456789:;<=>?@ABCDEFGHIJK
LMNOPQRSTUVWXYZ[\]^_`abcdefghijklmnopqrstuv
wxyz{|}~

We've just seen your excellent ad for **miniature zebras** in a recent back issue of Trader's Times. What is the **price** schedule for quantities over one **gross**?

NLQ Sans Serif

!"#\$%&'()*+,-./0123456789:;<=>?@ABCDEFGHIJK
LMNOPQRSTUVWXYZ[\]^_`abcdefghijklmnopqrstuv
wxyz{|}~

We've just seen your excellent ad for miniature zebras in a recent back issue of Trader's Times. What is the price schedule for quantities over one gross?

Character spacing

In normal draft and NLQ mode, you can select proportional spacing or a character spacing: of 10 or 12 characters per inch (cpi) with software commands. In high-speed draft *mode, only* 10 cpi printing is available. (Ten cpi is the **printer's** default character spacing.)

In the 10 and 12 cpi modes, each character gets an equal amount of space. In proportional mode, **the** spacing varies from character to character. A narrow letter like **the** lowercase i receives less space than the uppercase W.

The printout below compares the different types of spacing:

10 cpi

This is 10 CPI printing.
ABCDEFGHIJKLMNOP**QRSTU**VW**XYZ**
abcdefghijklmnopqrst**uvw**xy**z**

12 cpi

This is 12 CPI printing.
ABCDEFGHIJKLMNOP**QRSTU**VW**XYZ**
abcdefghijklmnopqrst**uvw**xy**z**

proportional spacing

This is proportional printing.
ABCDEFGHIJKLMNOP**QRSTU**VW**XYZ**
abcdefghijklmnopqrst**uvw**xy**z**

Condensed mode

Condensed mode reduces the size of characters to approximately 60% of their normal **width**, **In condensed mode more characters** fit on a line, which is useful for **spreadsheets and** other applications where you need to print the maximum amount of information on a page. Both 10 and 12 cpi **printing** can be condensed, but proportional printing cannot. To select condensed mode, turn on DIP switch 1-1.

The printout below compares normal **10** and 12 cpi printing with condensed **10** and 12 cpi printing.

This is 10 cpi printing.

This is **condensed 10 cpi printing.**

This is 12 cpi printing.

This is **condensed 12 cpi printing.**

Selecting an International Character Set

International character sets provide you with the characters and symbols used in other languages. In Epson ESC/P mode (which is selected when DIP switch 1-4 is off), you can select one of eight international character sets by setting DIP switches 1-6, 1-7, and 1-8 according to the table below. The table also shows the characters that differ in each international character set.

Country	ASCII code (hex)												DIP SW		
	23	24	40	5B	5C	5D	5E	60	7B	7C	7D	7E	1-6	1-7	1-8
0 U.S.A.	#	\$	@	[\]	^	`	{		}	~	ON	ON	ON
1 France	#	\$	à	°	ç	ß	^	`	6	ù	6	¨	ON	ON	OFF
2 Germany	#	\$	ß	À	Ö	Ü	^	`	ä	ö	ü	ß	ON	OFF	ON
3 United Kingdom	£	\$	@	[\]	^	`	{		}	~	ON	OFF	OFF
4 Denmark I	#	\$	@	Æ	Ø	Å	^	`	æ	ø	å	~	OFF	ON	ON
5 Sweden	#	□	£	À	Ö	Å	Ü	é	ä	ö	å	ü	OFF	ON	OFF
6 Italy	#	\$	@	•	\	é	^	`	à	ò	è	ì	OFF	OFF	ON
7 Spain I	Pt	\$	@	;	Ñ	¿	^	`	¨	ñ	}	~	OFF	OFF	OFF



CAUTION: Always be sure to turn off the printer before you change a DIP switch setting. After you set the DIP switches, turn on the **printer** to initialize the new settings.

Selecting an International Character Set

In addition to the eight character sets, you can select with DIP switches, you can select the five international character sets shown below using the ESC R software command. See the Command Summary in Chapter 9 for more information.

Country	ASCII code (hex)											
	23	24	40	5B	5C	5D	5E	60	7B	7C	7D	7E
5 Japan	#	\$	@	[¥]	^	`	{		}	~
9 Norway	#	□	£	Æ	Ø	Å	Ü	é	æ	ø	å	ü
10 Denmark II	#	\$	£	Æ	Ø	Å	Ü	é	æ	ø	å	ü
11 Spain II	#	\$	á	í	Ñ	¿	é	`	í	ñ	ó	ú
12 Latin America	#	\$	á	í	Ñ	¿	é	ü	í	ñ	ó	ú

Two character sets are available in IBM emulation mode (which is selected when DIP switch 1-4 is on). The Appendix shows these character sets. To select the character set with international characters (character set 2), turn off DIP switch 1-6, 1-7, or 1-8. Character set 1 is selected when all three of these switches are on.

Choosing a Character Table

In Epson ESC/P mode (which is selected when DIP switch 1-4 is off), you can turn off DIP switch 1-3 to select the italics character table or turn on the switch to select the Epson Extended Graphics character table. The Epson Extended Graphics character table contains international accented characters, Greek characters, mathematic symbols, and graphics characters for printing lines, comers, and shaded areas.

If you have an IBM or IBM compatible computer, select the Epson Extended Graphics table to print graphics characters as they appear on the screen. Since the character table setting affects only half the character set, you can still print text when the Epson Extended Graphics table is selected. Also, with the proper software commands you can print italics or graphics characters no matter which character table you select. (See the Command Summary in Chapter 9.)

Although most software programs work better with the graphics table, some programs require the italics table. Try switching tables if you have trouble printing lines and other graphics characters or if the printer does not print italics. Keep in mind, however, that your software may not have the capability to select graphics or italics. See Chapter 4 for information on how to enhance your printing using software commands.

Sample italics and Epson Extended Graphics characters are shown below.

italics

*àèùòì°£;¿ÑñπρτΑ&çßβ&øσ"ΑΟÙάούΈέΨ !"#\$%&`
() * + , - . / 0 1 2 3 4 5 6 7 8 9 : ; < = > ? @ A B C D E F G H I J K L M N O
P Q R S T U V W X Y Z [\] ^ _ ` a b c d e f g h i j k l m n o p q r s t u v w
x y z { | } ~ 0*

Data Dump Mode

Data dump mode is a special feature that allows experienced users to find the cause of communication problems between the printer and application programs. In data dump mode, an exact printout of the codes reaching the printer is produced.

To use data dump mode, follow these steps:

1. Make sure that paper is loaded. (You can use the built-in tractor units or the optional pull tractor for printing in data dump mode.) If the printer is on, turn it off.

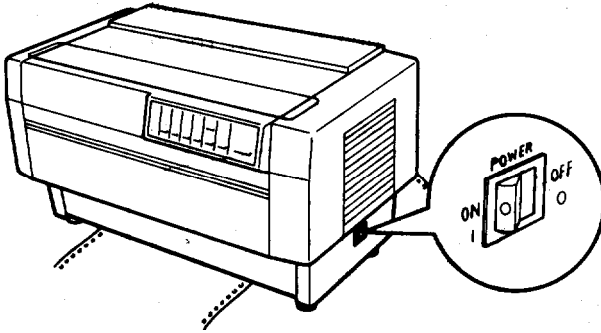

2. To enter data dump mode, hold down the FORM FEED and LINE FEED buttons and turn on the printer.

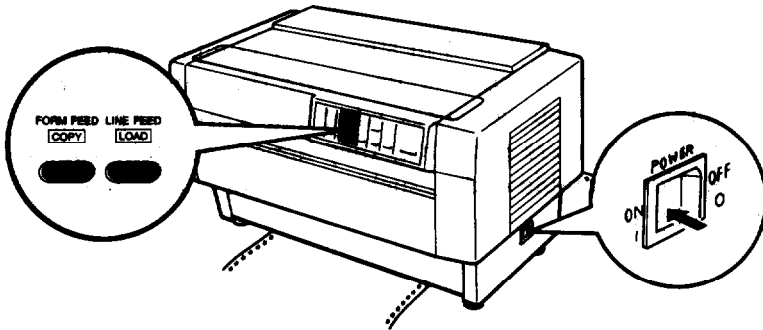

As an example of how to interpret a data dump printout, look at the first three hex codes on the second line of the printout sample (20 20 54). Each hex code 20 represents a space; the hex code 54 represents the letter T. Check the second line of the right column and you will find the letter T preceded by two spaces.

The chart below interprets the first six nonprintable codes.

Hex codes	Command	Function
1B 40	ESC @	Initialize printer
1B 52 00	ESC R 0	Select USA character set
1B 74 01	ESC t 1	Select Epson Extended Graphics character table
1B 36	ESC 6	Enable printable characters
12	DC2	Cancel condensed mode
1B 50	ESC P	Select 10 cpi

Chapter 4

Software and Graphics

Enhancing Your Printing	4-2
Print quality and fonts	4-2
Character spacing	4-3
Character size	4-4
Special effects and emphasis	4-5
Selecting tpestyles with Master Select	4-8
Graphics	4-10
The print head	4-11
The graphics commands	4-13
Column reservation numbers	4-14
Printing simple patterns	4-14
Printing taller patterns	4-16
Designing your, own graphics	4-17
Individual graphics commands	4-20
The reassignment command	4-20
User-defined Characters	4-22
Designing your characters	4-23
Sending information to your printer	4-24
Printing user-defined characters	4-26
Copy ROM characters to RAM	4-27
Mixing print styles	4-28

Enhancing Your Printing

You can obtain a wide variety of printing effects with the DFX-8000 printer, from changing the number of characters printed per inch to using special effects or adding emphasis to selected words and phrases. This section gives you a sampling of the features you **may** want to select with your software.

For software control of these features, see the instructions for your application program or look up their specific commands in the Command Summary in Chapter 9.

Print quality and fonts

The most fundamental changes you can make to printing on the DFX-8000 are in the print quality and fonts.

The DFX-8000 has three levels of print quality: high-speed draft, normal draft, and NLQ (Near Letter Quality). High-speed draft is ideal for rough drafts and large documents or reports that you need to print quickly. Normal draft is a bit slower, but offers higher resolution characters. Finally, NLQ takes a little longer but produces darker, more fully-formed characters suitable for presentation-quality documents. For NLQ printing, the DFX-8000 offers two fonts—Roman and Sans Serif.

The printout below shows the difference between high-speed draft, normal draft, NLQ Roman, and NLQ Sans Serif so that you can compare the different styles and densities.

```
High-speed draft is even faster.  
Draft printing is fast.  
NLQ Roman is clear and typewriter-like.  
NLQ Sans Serif is crisp and distinctive.
```

You can choose the print quality and NLQ fonts with software commands or DIP switches. However, high-speed draft can be selected only by setting DIP switch 2-2. (See the section on setting DIP switches in Chapter 3.)

Note: High-speed draft is available only when 10 cpi printing is selected: The only print enhancements that can be combined with high-speed draft are underline and double-wide. If other enhancements or character sizes are selected, high-speed draft is ignored and replaced by normal draft.

Character spacing

To add greater variety to your documents, the DFX-8000 has two fixed character spacings and proportional spacing. Each one can be selected with a software command.

For two of the built-in fonts, normal draft and NLQ, you can choose a character spacing of 10 cpi (characters per inch), 12 cpi, or proportional spacing. The printout below compares the two types of character spacing.

This is 10 cpi printing.
This is 12 cpi printing.

In 10 and 12 cpi, each character is given the same amount of space. The width of proportional spacing, however, varies from character to character. Therefore, a narrow letter like *i* receives less space than a wide letter like *W*. The width of each proportional character is given in the Appendix.

Enhancing Your Printing

The following printout compares 10 cpi spacing with proportional spacing.

This is 10 cpi printing.
This is proportional printing.

Note: High-speed draft is available only in 10 cpi. If you select 12 cpi or proportional spacing, the print speed temporarily switches to normal draft until 12 cpi or proportional spacing is turned off.

Character size

In addition to the two fixed spacings and proportional spacing, the DFX-8000 offers three other modes that can change the size of your printing. These modes are double-wide, double-high, and condensed.

The double-wide mode doubles the width of any size characters, while the double-high mode doubles the height of any size characters. These modes are useful for **emphasizing** headings in reports and making displays, but are usually not suitable for large amounts of text. These modes can also be combined to obtain even more impressive printing results.

This is normal 10 cpi printing.
This i s double-wide .

This is double-high.

**This is double-wide
and double-high.**

Both 10 and **12** cpi printing can be reduced to about 60% of their normal width using condensed mode. This mode is particularly useful for printing wide spreadsheets because condensed 12 cpi allows you to print up to 160 characters on an g-inch line and 272 characters on a **13.6-inch** line.

Condensed can be selected **with software commands** or a 'DIP switch. (See the section on **setting DIP** switches in Chapter 3.) Even if you turn on **condensed** with the DIP switch, you **can still** turn it off with **a software command**.

Condensed 10 cpi gives **you more** characters **on** a line.

Condensed 12 cpi **gives** you **even** more.

Notes:

- Both 10 and **12** cpi can be condensed, but proportional spacing cannot.
- When condensed is selected in NLQ, NLQ is replaced by normal draft.

Widening or narrowing the characters also widens or narrows the space between words and letters. Because word processors usually create a left margin by printing spaces, you may need to change the number of characters on a line to keep the margins correct if you change widths.

special effects and emphasis

The DFX-8000 offers two ways of emphasizing parts of your text and also allows you to use underlining, superscripts, subscripts, and italics. These features can be controlled directly by software commands. Many application **programs can** also **produce** these effects if they are **properly installed**. **See the instructions** for your application program for details.

Emphasized and ~~double-strike~~ printing

Emphasized and ~~double-strike~~ printing can give text added distinction. In emphasized mode, the DFX-8000 prints each character twice as the print head moves across the paper, with the second character printed slightly to the right of the first. This **process** produces darker, more fully-formed **characters**.

In double-strike mode, the print head goes over each line twice, making the text bolder. For even greater boldness, you can combine emphasized and double-strike. While NLQ is in use, however, double-strike is **ignored** because NLQ characters are already formed by two passes of the print head.

This is normal draft printing.

This is emphasized draft printing.

This is double-strike in draft mode.

This is double-strike and emphasized combined.

Italic printing

You can use italics for special emphasis or as an alternative typeface.

This is Roman printing.

This is italicized Roman printing.

Underlining

The underline mode provides an automatic way of fully underlining any piece **of** text. **This mode underlines** spaces, superscripts, and subscripts without a break. Most word processors take advantage of this feature, but **some** programs use the underline character **instead**. If this happens, check your **program** for an underlining **option**.

This is continuous underlining.

Superscripts and subscripts

Superscripts and subscripts can be used for printing footnote numbers and mathematical formulas. The example below 'shows underlining and subscripts combined in a mathematical formula.

$$\text{a v e r a g e} = \frac{\underline{(a_1 + a_2 + \dots + a_n)}}{n}$$

Selecting typestyles with Master Select

Your printer has a special ESCape code called Master Select that allows you to choose **many** combinations of nine different printing **modes**:

- 10 cpi
- 12 cpi
- proportional
- condensed
- emphasized
- double-strike
- double-wide
- italics
- underline

For more information on sending ESCape codes to your printer, see Chapter 9.

The format of the Master Select code is shown below:

ASCII:	ESC	!	<i>n</i>
Decimal :	27	33	<i>n</i>
Hexadecimal:	1B	21	<i>n</i>

The variable *n* is a number that identifies the typestyle or combination. To find the value of *n*, refer to the table below and add up either the decimal or hexadecimal numbers for the features you want.

Feature	Dec.	Hex.
10 cpi	0	00
12 cpi	1	01
proportional	2	02
condensed	4	04
emphasized	8	08
double-strike	16	10
double-wide	32	20
italics	64	40
underline	128	80

For example, to print a title you may want to use double-wide 12 cpi characters and print them in double-strike mode. You would add these three decimal numbers together to calculate the value of n .

12 cpi	12
Double-strike	16
Double-wide	<u>32</u>
$n =$	49

After calculating the value of n , you would use the Master Select command to send the value to the printer.

ASCII:	ESC	↑	1
Decimal:	27	33	49
Hexadecimal:	1B	21	31

Print quality and font selection are not part of **Master Select** and must be set separately, using the ESC x and ESC k commands. The draft font printing speed must be set using DIP switch 2-2. (See the section on 'setting DIP switches in Chapter 3.)

There are four more things to **consider** when using the Master Select command:

- Master Select cancels any of **the listed features** that you do not set. For example, if you **have already set 12 cpi**, and you try to use Master Select to set **emphasized double-strike** only, the character spacing is reset to 10 **cpi**.
- Proportional **spacing** overrides 10 cpi, 12 cpi, and condensed.
- Only 10 cpi, **underline**, and double-underline are available in high-speed draft mode.
- When emphasized and condensed are selected, emphasized is ignored.

Graphics

The dot graphics mode allows your printer to produce pictures, graphs, charts, or almost any other pictorial material you can think of.

Because many commercial software programs use graphics, you may be able to print pictures and graphs like the one on this page by simply giving your software a few instructions.

The quickest and easiest way to print graphics on your printer is to use a commercial graphics program. With such a program you usually create an image on your monitor and then give a command to send the image to the printer. If you use commercial software that produces graphics, all you need to know about dot graphics is how to use the software. If, on the other hand, you wish to do your own programming or merely wish to understand how the printer prints graphics, read on.

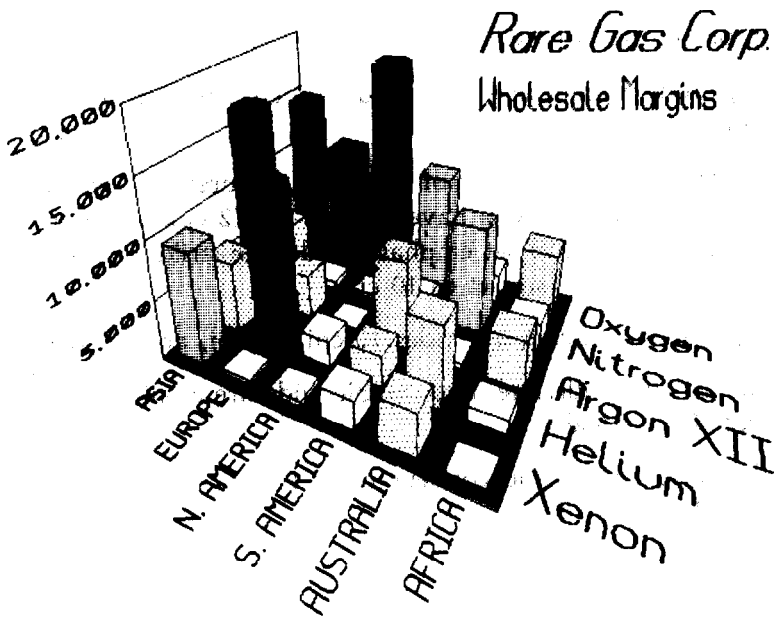

The print head

To understand dot graphics you need to know a little about how your printer's print head works.

As the print head moves across the page, electrical impulses cause the pins to fire. Each time a pin fires, it strikes the inked ribbon and presses it against the paper to produce a small dot. As the head moves across the page, the pins fire time after time in different patterns to produce letters, **numbers**, or symbols.

Dot patterns

The DFX's print head is able to print graphics as well as text because graphic images are formed on the printer about the same way that pictures in newspapers and magazines are printed. If you look closely at a newspaper photograph, you can see that it is made up of many small **dots**. Your **printer** also **forms** its **images** with patterns of dots, **as** many as 240 dot positions per inch horizontally and 72 dots vertically. The images printed by the printer can, therefore, be as finely detailed **as the one on page 4-10**.

In **its main graphics mode, your printer prints** one **column of** dots for each code it receives, and it uses only the top eight of the nine pins. Therefore, your **graphics** program **must** send codes for dot patterns, one **number** for **each column** in a line. **For each of those** columns, the print **head prints the pattern** of dots **you** have specified.

To print figures taller than eight dots, the print head makes more than one pass. The printer prints one line, then advances the paper and prints another, **just** as it does with text.

To keep the print head from leaving **gaps between** the graphics lines as it does between the text lines, **the line** spacing must be changed to eliminate the **space between lines**. **With a change** in line spacing, your printer can print finely detailed graphic images that give no indication that they are made of separate lines, **each** no more than 8/72nds of an inch tall.

Pin labels

To tell the printer **which pins to fire** in each column, **you need a** numbering system that separately **identifies each** of the eight pins. Since there are 256 possible combinations of the eight pins in each *section*, you **use the numbering system shown below.**



To fire any one pin, you send its number. To fire more than one **pin at the same time**, add **up the numbers** of the pins and 'send' the sum to **the printer. With these labels for the pins**, you find the **top pin** by sending 128. **To fire the bottom pin**, you send 1. **If you want to fire only the top and bottom pins**, you **simply add 128 and 1, and send 129.**

By **adding** the appropriate **label** numbers together, you **can** fire any **combination of pins. Below are three examples of how to calculate the number that will fire a particular pattern of pins.**

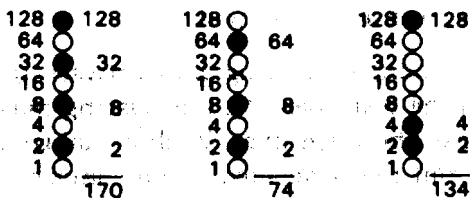

With this numbering system, any **combination** of the eight pins adds up to a decimal number between 0 and 255, and no numbers are **duplicated**. **Before you can put these numbers in a graphics program, however, you need to know the format of the graphics commands.**

The graphics commands

The **graphics mode** commands are quite different from most other commands. For most of the other modes, such as **emphasized** and **double-strike**, one command turns the mode on and another turns it off. For **graphics**, the command is more complicated because the command that turns on the graphics mode also specifies how many columns of **graphics will be printed**. After the printer receives this command, it interprets the numbers which follow as pin patterns and prints them on the paper.

Your printer has one command that allows you to use any of the eight **graphics** options. The format of the command is:

ESC * *m n1 n2 data*

In this command, *m* selects the **graphics option** and *n1* and *n2* specify, the **number of columns to reserve for graphics**. The available **graphics options are** listed below.

Option	<i>m</i>	Horiz. density (&Win.)
Single-density	0	60
Double-density	1	120
High-speed double-density*	2	120
Quadruple density*	3	280
Plotter (1:1)	4	72
CRT II	6	90
Double-density plotter	7	144

* Adjacent dots cannot be printed in this mode.

Column reservation numbers

Even in **single-density** graphics mode, one 8-inch line can accommodate 480 columns of graphics; in quadruple-density, almost 2000 columns can fit on the same 8-inch **line**. Since the `&inter` does not use decimal numbers larger than **255**, the graphics mode command uses two numbers for reserving columns.

To figure ***n1*** and ***n2***, divide the total number of columns by 256. The result is ***n2***; the remainder is ***n1***. Since the command is set up for two numbers, you must supply two even if you need only one. When you need fewer **than 256 columns**, just make ***n1*** the number of **columns** you are **reserving** and make ***n2*** a zero. For example, if you wish to **send 1632 columns** of **graphics** data; ***n1*** should be **96** and ***n2*** should be **6** because **$1632 = 96 + (6 \times 256)$** .

If you are using a programming language with MOD (modulus) and INT (integer) functions, you can use the following formulas to **calculate *n1* and *n2***, in **which *n*** is the **total number of** columns:

$$n1 = n \text{ MOD } 256$$

$$n2 = \text{INT} (n/256)$$

The **printer** will **interpret** the **number of bytes determined** by ***n1*** and ***n2*** as **graphics data**, no matter **what codes they are**. This means that you must be sure to **supply enough bytes of graphics** data or the printer will stop and wait for more data and will seem to be locked. If, on the other hand, you supply too much graphics data, the excess **will** be interpreted and printed as regular text.

Printing **simple** patterns

The first **example** is just a `s&&` program to show you how the graphics command, column reservation numbers, and data can be used in a BASIC program.

Type and run the following program; be especially careful to include all semicolons. The program produces the printout you see below.

```
10 WIDTH"LPT1:",255
20 LPRINT CHR$(27);"***";CHR$(0);CHR$(40);CHR$(0);
30 FOR X=1 TO 40
40 LPRINT CHR$(170);
50 NEXT X
```



Line **20** specifies single-density graphics mode and also reserves **40** columns for graphics. Line 30 begins a loop to supply **40** bytes of data. Line 40 contains the number 170, which produces the first pin pattern shown in the section on pin labels, and line 50 finishes the loop.

Note: Some software programs (including most versions of BASIC) automatically insert carriage return and line feed codes after every 80 or 130 characters. This is usually no problem with text, but it can spoil your graphics. Two **extra columns** of graphics are printed in the middle of the ones you send, and two data numbers are left over and printed as text.

In some versions of BASIC, you can prevent unwanted **control** codes in graphics by putting a WIDTH statement 'at the **beginning** of all graphics programs. The format in many **BASIC** versions is either WIDTH "**LPT1:**", **255** or **WIDTH LPRINT 255**. Check your software manual for the proper format.

Printing taller patterns

The next **example** shows how several' lines of graphics can be formed into a figure taller than eight dots. It uses programming techniques for producing textured or repetitive patterns.

In the following program, the lines inside each pair of FOR and NEXT statements **are** indented so **that you** can see how the program works; the spaces are not needed for the program to run.

```
100 WIDTH "LPT1:",255
110 LPRINT CHR$(27);"A";CHR$(8);
120 FOR R=1 TO 6
130   LPRINT CHR$(27);"K";CHR$(100);CHR$(0);
140   FOR X=1 TO 50
150     LPRINT CHR$(170);CHR$(85);
160   NEXT X : LPRINT
170 NEXT R
180 LPRINT CHR$(27);"@"
```

If you **run** the program,, you **will** see bow it combines six print lines into a **pattern**.

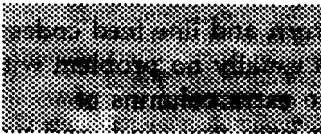

There are five basic steps that the program goes through to produce this kind **of pattern**:

1. The computer is prevented from adding any extra characters by the WIDTH statement (line 100).
2. The line spacing is changed to **8/72** of an inch — the height of the dot patterns used in the program (line 110).
3. The program goes through the graphics commands the required number of times (line **120** and 170).

4. A new graphics **command is used** for each **line printed (lines 130 to 160)**. This part of the program is **similar to** the last example, but two columns are printed each time through the loop, making a total of 100.
5. The last important thing to do is to reset the printer to its initial settings, including the normal line spacing (line 180).

Notice that the graphics command (**ESC K**) **can** be in effect for only one print line. To print more than one line of graphics, the graphics command must be **issued before each** line.

Designing your own graphics

This section takes you through the development of a graphics program. The example here is not especially complicated, but it does include the **same** steps you would use for a more complex figure.

First you **must decide** which graphics density you want. The figure below **shows the differences between three** common **modes** so that you can **choose the one you want**. See page 4-13 for a **list** of available **graphics** densities.

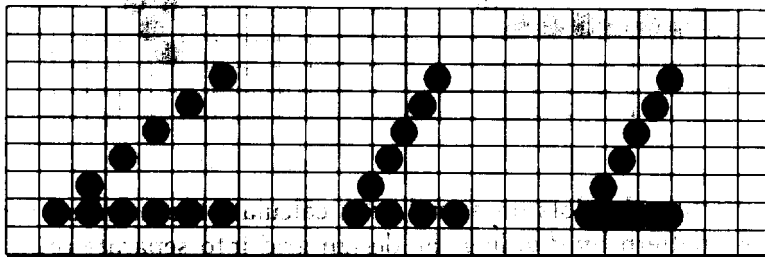

Single

High-speed
double

Double

Graphics

In the figure on the previous page, you can see the main rules for graphics design in the three densities:

- In single-density, no dots can be placed on vertical lines.
- In double-density, dots can be placed on vertical lines, and they can overlap.
- In high-speed double-density, dots can be placed on vertical lines, but no dots can overlap.

After choosing the desired density, you design your **figure** by plotting dots on graph paper.

The high-speed double-density design shown below should point you in the right direction for your own work.

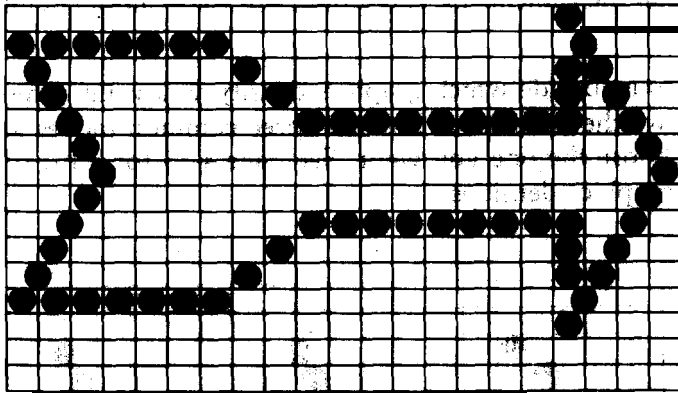

After plotting the **dots** on a **grid**, you calculate **the numbers** for each pin **pattern** by dividing the design grid into separate print lines. For the arrow design, the grid was divided into two lines, each seven dots high. Then each column was examined to calculate the graphics data. The results for the first line are shown in the figure on the next page. The pin values are on the left and the sums at the bottom of each column.

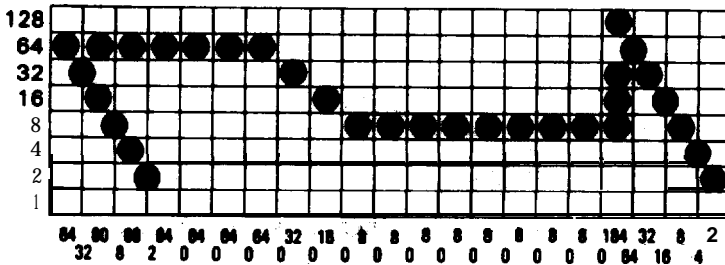

The numbers for the second line were calculated in the same way. Once the numbers for the pin patterns are calculated, they are put in the program in DATA statements, separated by commas.

The following program is similar to the example on page 4-16. This program selects 7/72-inch line spacing because only seven pins are used. Because the data is not repetitive, each column of graphics data is read from the DATA statements and sent to the printer. The design is 41 dot positions wide, therefore, both lines 130 and 140 use the number 41.

```

100 WIDTH "LPT1:",255
110 LPRINT CHR$(27);"A";CHR$(7);
120 FOR ROW=1 TO 2
130 LPRINT CHR$(27);"Y";CHR$(41);CHR$(0);
140 FOR COLUMN=1 TO 41
150 READ N
160 LPRINT CHR$(N);
170 NEXT COLUMN
180 LPRINT
190 NEXT ROW
200 END
210 DATA 64,32,80,8,68,2,64,0,64,0
220 DATA 64,0,64,0,32,0,16,0,8,0
230 DATA 8,0,8,0,8,0,8,0,8,0,8,0,8,0,8,0
240 DATA 184,64,32,16,8,4,2
250 DATA 8,16,40,64,136,0,8,0,8,0
260 DATA 8,0,8,0,16,0,32,0,64,0,64,0
270 DATA 64,0,64,0,64,0,64,0,64,0,64,0,64,0
280 DATA 116,8,16,32,64,128,0

```

Graphics

When you run this program, it produces the following printout.

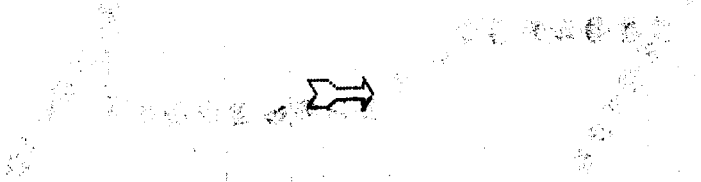

If you want to see the **figure** in **other** densities, change the Y in line **130** to **L** or **Z**.

Individual graphics commands

There are four **individual graphics commands** that are very much the same **as the ESC * command**, but each one works **for** only one graphics option. **Note** that these **commands contain one less** variable than the **ESC * command** because they do not **need** to, select a graphics option.

They are shown below:

Command	Function	ESC * Format
ESC K	Single-density	ESC * 0
ESC L	Double-density	ESC * 1
ESC Y	Double-density, high-speed	ESC * 2
ESC Z	Quadruple-density	ESC * 3

The reassignment command

The DFX-8000 has a command that allows you to change the graphics option assigned to any of the four individual graphics options commands.

The command looks like this:

ESC ? s m

The letter *s* represents the command that you wish to **change** the assignment for (**K**, **L**, **Y**, or **Z**) and **m** is the number of the graphics option that you want to assign **to it**. For example, to **change** the **ESC K** command to use the CRT **I** graphics option, the command in BASIC is:

```
LPRINT CHR$(27);"?";"K";CHR$(4)
```

This is a quick way to change the aspect ratio of the design that you are printing. **Changing** the graphics option will change the width without changing the height.

User-defined Characters

With **this printer**, it **is** possible to define and print characters of your own design. You can design an entirely new alphabet or typeface, create characters for special applications such **as** mathematical or scientific symbols, **or create** graphic patterns with user-defined characters to serve **as** building blocks for larger designs.

Below, you can see samples of typefaces created with the **user-**defined character function.



You can make the task of defining characters easier by using a commercial software program that assists you in creating characters or simply supplies you with sets of characters already created. Also, some popular commercial software programs take advantage of the printer's **user-defined** character function to enhance printouts. (These characters are called download characters in some programs.)

The standard characters are stored in the printer's Read Only Memory (ROM), and the user-defined characters are stored in the printer's Random **Access** Memory (RAM).

In Epson **ESC/P** mode, user-defined characters remain in the printer's memory even after the printer is turned off. You can select the **user-**defined character set by turning on DIP switch **2-1** without defining the same characters again. However, in the IBM emulation mode, user-defined characters are cleared whenever the printer is **turned** off, including characters defined in Epson **ESC/P** mode.

Designing your characters

User-defined characters are like dot graphics because you send the printer precise instructions on where you want each dot printed. In fact, planning a user-defined character is like planning a small dot graphics pattern. In this mode, you treat the printer as if it had a single column of nine pins.

Design grids

To design a draft character you use a grid that has nine rows and eleven columns as shown below. The following figure shows three of these grids. Most characters **do not use the two rows below the heavy line**.

Those rows are only for characters with descenders, like **y** and **g**. Also, even though you can use up to **11** columns, it is best to leave the last **two blank** for **the space between characters**.

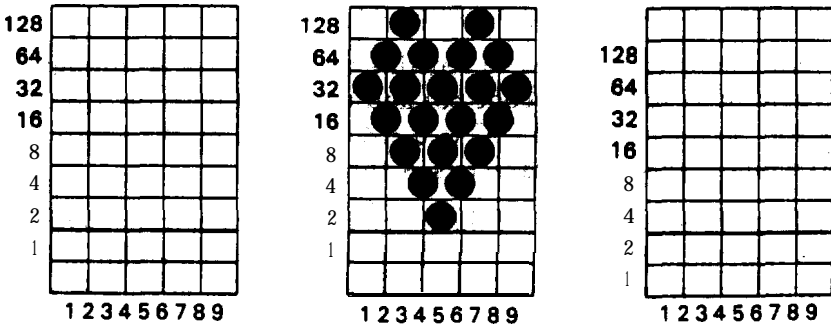

The grid in the middle shows the design. You can use up to eight pins of your printer's print head in a single user-defined character. The design above uses the top eight pins, but you can also use the bottom eight by using the grid on the right as explained later in this section.

User-defined Characters

Sending information to your printer

Once the **-character** is planned on the grid, you simply add **the** pin values for each column together, just as you do for **graphics**. **The last step in defining a character is** to send **this information to the printer**.

The command to define characters is relatively complex:

ESC & 0 n1 n2 a1 d1 . . . dn

You can define more than one character with a single command.

The values **n1** and **n2** are the ASCII codes of the first and last characters you are **defining**. If you are defining only one character, **n1** and **n2** are the same. You **can** use any codes between 0 and **255** decimal for **n1** and **n2** except the following codes: **7, 8, 9, 10, 11; 12, 13, 14, 15, 18, 19, 20, 24,** and **27** decimal. Also, it is best not to define decimal **32**, which is the code for a space.

You can also use other codes by using the **ESC 6** and **ESC I** commands. (See the Command **Summary** in Chapter **9**.)

For example, if you wanted to redefine the characters A through **Z**, **n1** would be A (or ASCII code **65**) and **n2** would be **Z** (or ASCII code **90**). So the command **ESC & 0 AZ** (followed by the appropriate data) would replace **the** characters A through **Z**.

Following the specification of the range of characters to be defined in this command is one number (**a1**) that specifies the width of the **character and whether** it uses the top eight pins or the bottom eight pins.

The last part of the command (**d1..dn**) is the actual data that defines the dot **patterns** for each column of each character. Since a character can use up to eleven columns, you must supply eleven data numbers for each character even if some columns are blank.

Note: Be sure to **turn** off DIP switch **2-1** before defining characters. The **ESC &** command is invalid if this switch is on.

The following character definition program should help make this clear:

```

100 LPRINT CHR$(27);"x";CHR$(0);
110 LPRINT CHR$(27);"&";CHR$(0);
120 LPRINT"@@";
130 LPRINT CHR$(136);
140 FOR I=1 TO 11
150 READ A: LPRINT CHR$(A);
160 NEXT I
170 LPRINT "#####"
180 LPRINT CHR$(27);"%";CHR$(1);
190 LPRINT "#####"
200 LPRINT CHR$(27);"%";CHR$(0);
210 LPRINT "#####"
220 END
230 DATA 32,80,168,84,42,84,168,80,32,0,0

```

The two at signs (@) in line 120 (*n1* and *n2*) represent the range of characters being defined (in this case, a range of one). Line 130 contains *a1*.

The information about the actual character design (which is contained in the data statements at the end of the program) is sent to the printer in the loop between lines 140 and 160.

Specifying the width and height

The example program uses 136 for *a1* (in line 130 of the definition program), but you can use other values. The number *a1* specifies two things: the width of the character and its position on the grid. The width is used when the character is printed in proportional mode.

If you want to use the bottom eight pins, use the third grid in the illustration on page 4-23.

User-defined Characters

A value of 136 is suitable for all characters that use the top eight pins, start in column 1, and finish in column 9. For a character of the same width, but printed with the bottom eight pins, **al** should be 8. For any other character, follow **these rules to calculate al**:

1. If you design a character narrower than nine columns, you can balance the number of empty columns on either side with the following method: starting with **al** equal to 8, subtract 1 for every blank column on the right and add 16 for every blank column on the left.
2. If the character uses the top eight pins, add 128.

For example, if a character uses the top eight pins, starts in column 3, and ends in column 7, the calculation is as follows:

- start with **al** = 8
- subtract 2 for two blank columns on the left, giving **al** = 6
- add 32 for two blank columns on the left, giving **al** = 38
- add 128 to print with the top eight pins, so that **al** = 166.

Printing user-defined characters

If you entered the example program on page 4-25 you defined a heart and placed it in the **RAM** location for ASCII code 64 (replacing the at sign). You can now print out a three-line sample of your work. The first and third lines (printed by lines 170 **and** 210 of the program) print the normal at sign; the second line (line 190) prints the heart that you defined.

Run the program to see the printout below.

```
@@@@@  
♥♥♥♥♥  
@@@@@
```

As you can see, both sets of characters (the original ROM characters that the printer normally uses and the **user-defined** character set) **remain** in **the** printer available for your use. The command to switch between the two sets is used in line 180 and 200. It is:

ESC % n

If **n** is equal to 0, the normal ROM character set is selected. If **n** is equal to 1, the **user-defined** character set is selected. You can also select one of the two character sets with DIP switch 2-1. **If you** select the **user-defined** character set before you have defined any characters, the command is ignored and the ROM characters remain in use.

You may switch between **character** sets at any time, even in the middle of a line. To try this, place semicolons at the end of lines 170 and 190 in the preceding program.

Copying ROM characters to RAM

After **running** the previous sample program, if you select the **user-defined** character set and try to print other **characters**, **only** the heart will print. Since no other characters are in the printer's **user-defined** RAM area, other characters print as spaces.

In many cases, you will want to redefine only a few of the characters to suit your needs; the rest of the alphabet will work fine as it is. As you have seen, it is possible to switch back and forth at will between the normal character set and **user-defined** character set. It is, however, rather inconvenient.

Therefore, your printer has a command that allows you to copy all of the standard characters from ROM to the user-defined character set.

The command format is:

ESC : 0 n 0

User-defined Characters

Note: This command cancels any user-defined characters you have created. You must send this command to the printer before you define **characters**. Also, **check** that **DIP switch 2-1** is off before sending. this command to your **printer**.

If you use this command at the beginning of a program, then define your special characters and select the **user-defined character** set., you can print with the user-defined character set as your **normal character** set. You never need to switch **back** and forth between sets.

Mixing print styles

The user-defined character **set** can be used in combination with **most print** styles (except **NLQ**). For example, emphasized and **double-wide** work well with user-defined characters,

The sample below shows the heart **character printed** in two different styles.

```
Normal:      ♥♥♥♥♥♥
Double-wide: ♥♥♥♥♥♥
```

In IBM emulation mode, you use a different method to define characters. For more information, see page 9-50 in the Command Summary.

Chapter 5

Using the Printer Options

Pull Tractor	5-2
Installing the pull tractor	5-2
Paper handling	5-5
Removing the pull tractor.....	5-15
Paper Cutter	5-19
Installing the paper cutter	5-19
Paper handling	5-23
Removing the paper cutter.....	5-28
Interface Boards.....	5-32
Choosing an interface	5-32
Compatible interfaces	5-33
Installing an interface board	5-33
#8143 New Serial interface board	5-39

Pull Tractor

The optional pull tractor (#8309) provides optimum continuous paper handling. The pull tractor is especially useful with continuous multi-part forms and labels. For best results, use the pull tractor along with one of the built-in push tractors, as described in **this** section.

Installing the pull tractor

To install the pull tractor, you need a cross-head screwdriver. The following steps show you how to install the pull tractor.

Note: If you plan to use the pull tractor with **the** built-in rear tractor, load paper onto the rear tractor before you install the **pull** tractor. See the section on loading paper onto the rear tractor in Chapter 2.

1. Turn off the printer and open the paper separator cover.

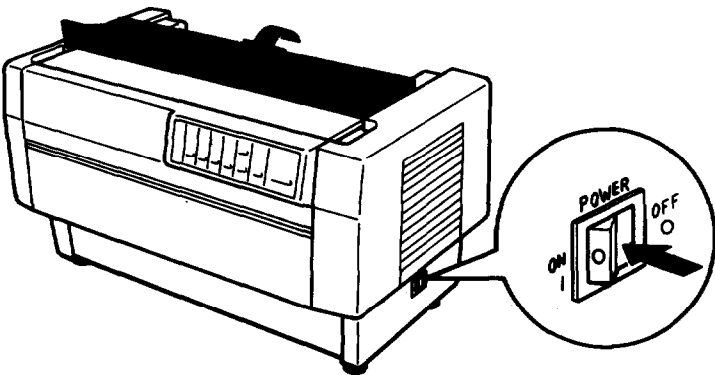

2. Use a cross-head screwdriver to remove the two screws securing the paper separator to the printer. Then lift the paper separator off the printer.

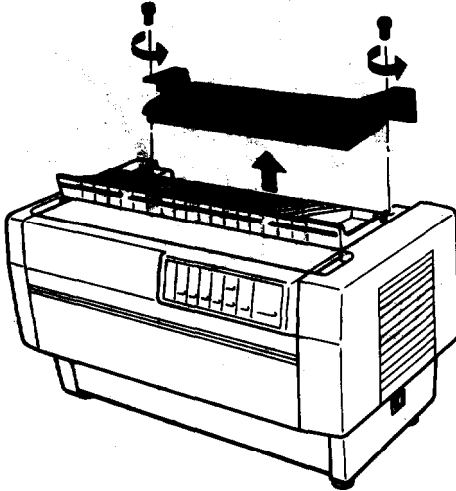

3. Using the two screws you just removed from the printer's original paper separator, install the paper separator that comes with the pull tractor.

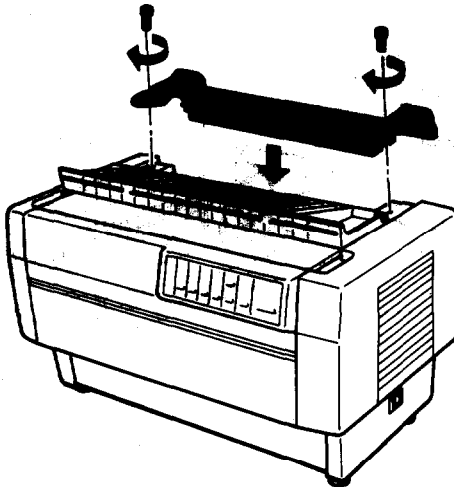

4. Close the paper separator cover and open the top cover.

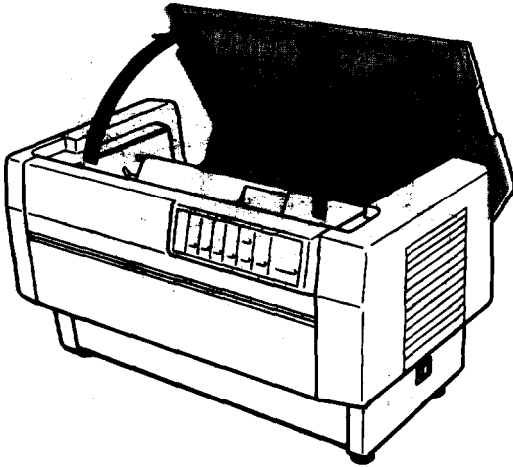

5. Holding the **pull** tractor with its gears to the left, fit the tractor's front notches over the mounting shaft in the printer.

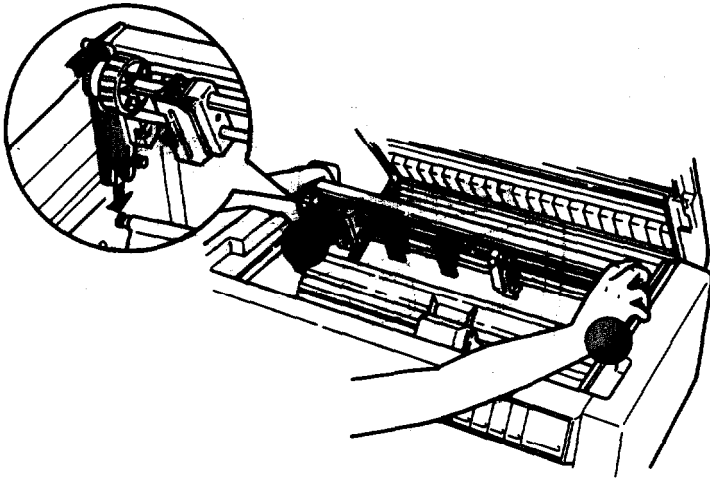

6. Open the paper bail using the tab on its right side. Then tilt the pull tractor back until its rear latches click into place over the printer's rear mounting pins.

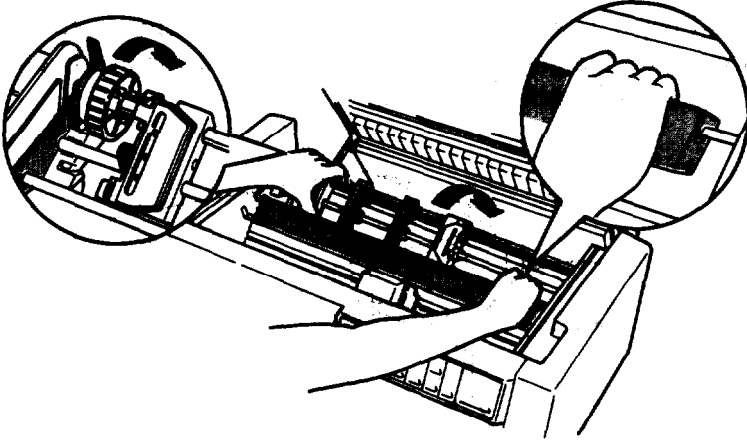

7. Close the paper bail and then close the top cover.

Paper handling

If you are using labels or multi-part forms with more than four parts including the original, use the pull tractor **with** the built-in front tractor.

You can switch between the front and rear tractors at any time **when you are using the pull tractor**. Just press the **FRONT/REAR** button and then use the **FORM FEED** button to feed the paper the additional distance to the **pull** tractor. (Labels require special handling. see **the section** on labels in Chapter 2.)



WARNING: The short tear-off feature does not work when the pull tractor is installed. To remove a document, press the **FORM FEED** button to advance the paper to a point where you can tear it off.

Pull Tractor

Using the pull tractor with the **front tractor**

The steps below show you how to load paper when you use the optional pull tractor with the printer's built-in front tractor.

- 1. Load paper** to the loading position on the front **tractor**. (See the section on **loading** paper onto the front tractor **in Chapter 2**.) Then take the printer off line.

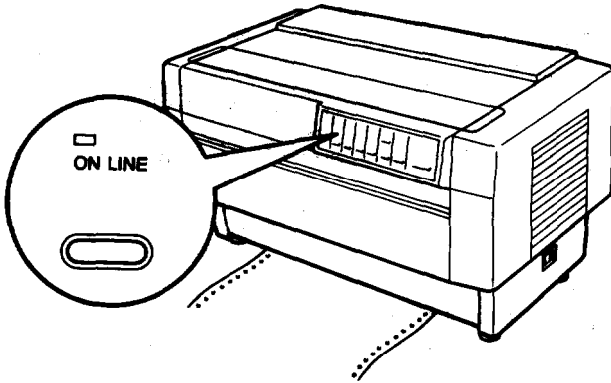

- 2. Open the top cover.**

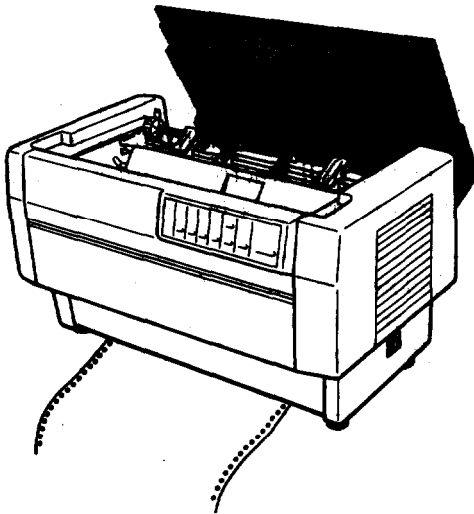

3. Press the **FORM FEED** or **LINE FEED** button to advance the paper over the pull tractor.

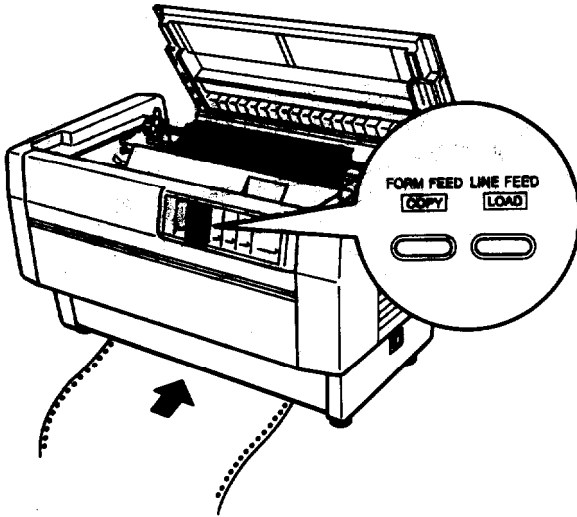

4. Release both sprocket lock levers on the pull tractor by pulling them toward you. Then open both sprocket covers.

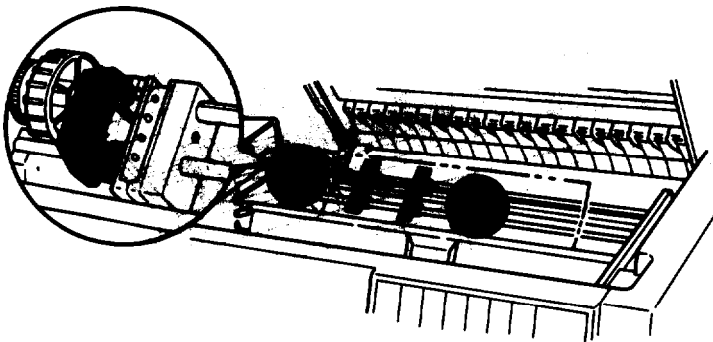

Pull Tractor

5. Adjust the sprocket units to match the width of your paper.

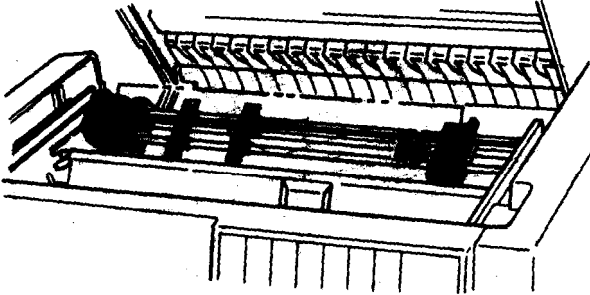

6. Slide the two paper supports so that they are spaced **evenly** between the two sprocket units.

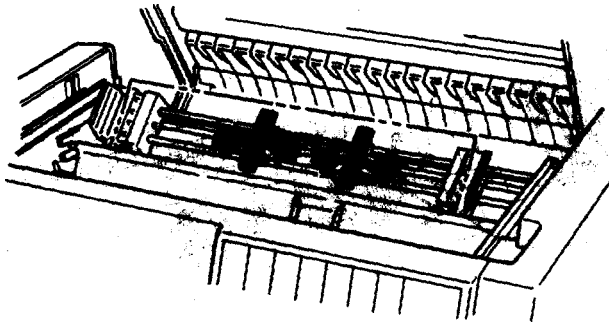

7. Fit the paper's sprocket holes over the pins on the sprocket units and close the sprocket covers.

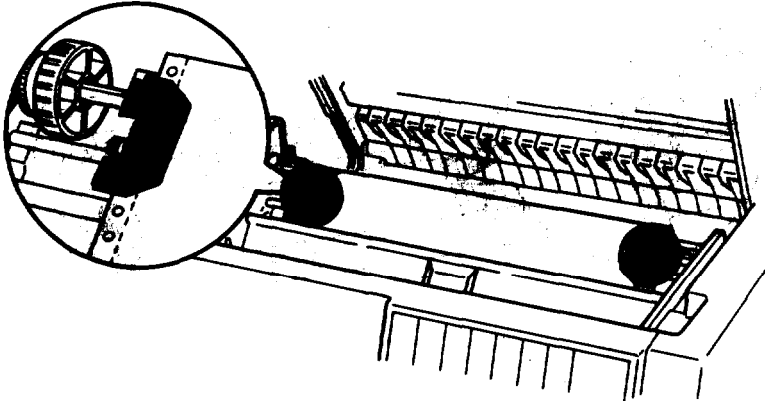

CAUTION: Be sure the sprocket units of the built-in front tractor and the optional pull tractor are aligned.

8. If there is slack in the paper, or if the paper's sprocket holes do not easily fit onto the tractor pins, press in the pull tractor knob and **turn it** to adjust the position of the paper.

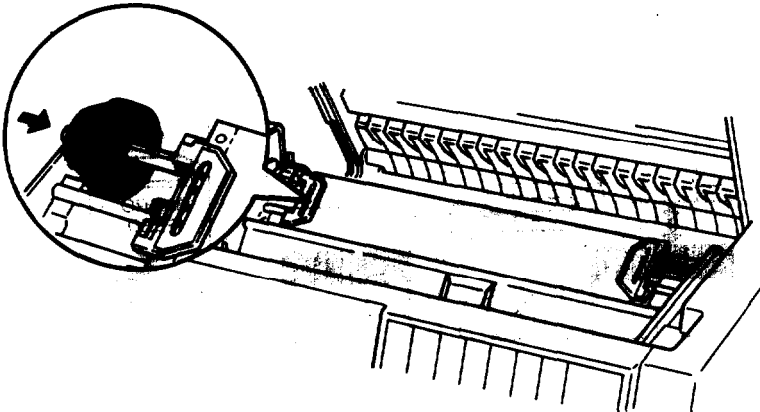

9. Slide the sprocket units so that the paper is straight and smooth, and then lock them into place.

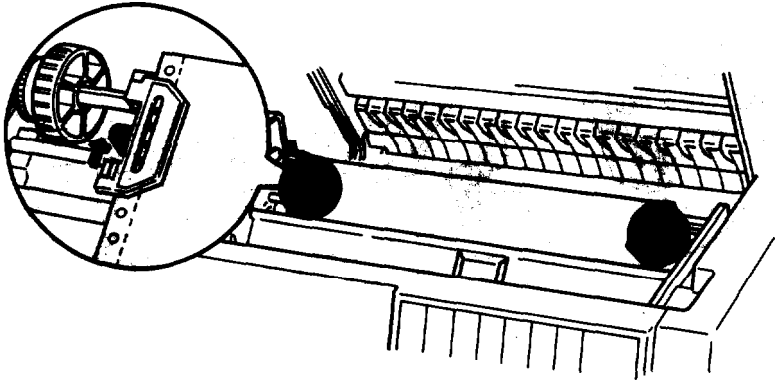

CAUTION Be sure the sprocket units are not too far apart. **If they pull your paper too tightly or tear the edges of the paper holes, a paper jam may result.** To **remove any excess tension** in your paper, release the right sprocket unit and lock it again.

10. Adjust the top of form position as described in Chapter 3.

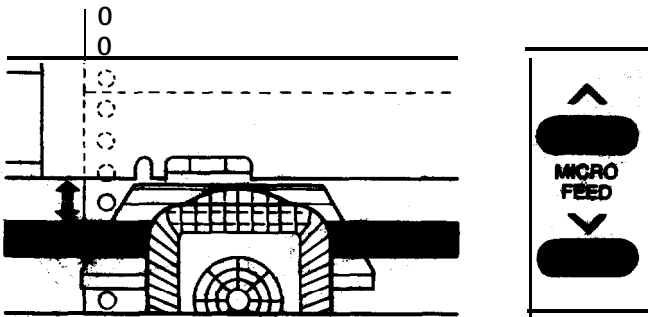

11. Close the top cover. Make sure the edge of the first sheet emerges below the paper separator.

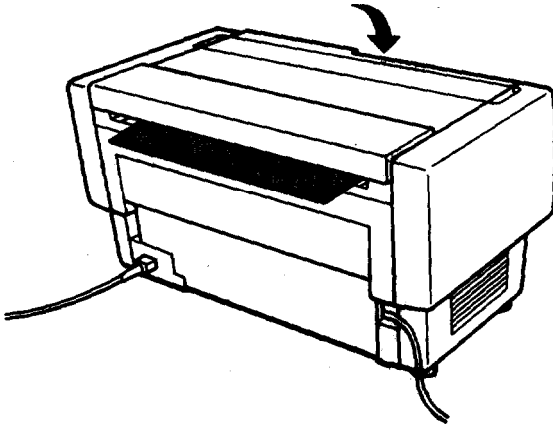

12. Press the **ON LINE** button to put the printer on line so it is ready to print.

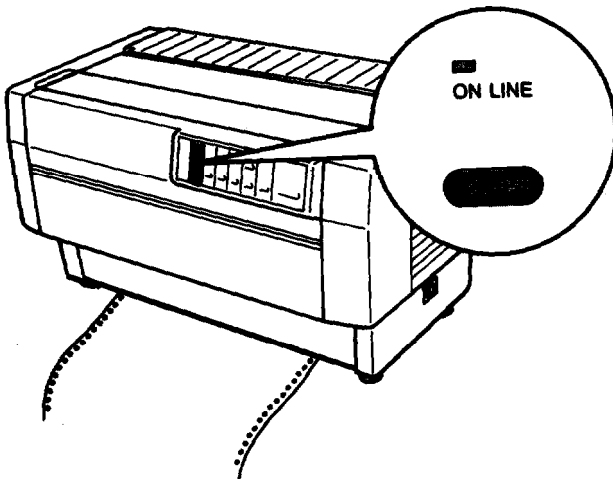

Pull Tractor

Using the pull tractor with the rear tractor

This section describes how to load paper when you use the optional pull tractor with the built-in rear tractor. If paper is already loaded onto the rear tractor, follow steps 2 through 12 in the previous section to load paper **onto the** pull tractor. If paper is not loaded onto the rear tractor, follow the steps below to load paper onto the pull tractor.

1. Turn on the printer and take it off line. Then open the top cover.

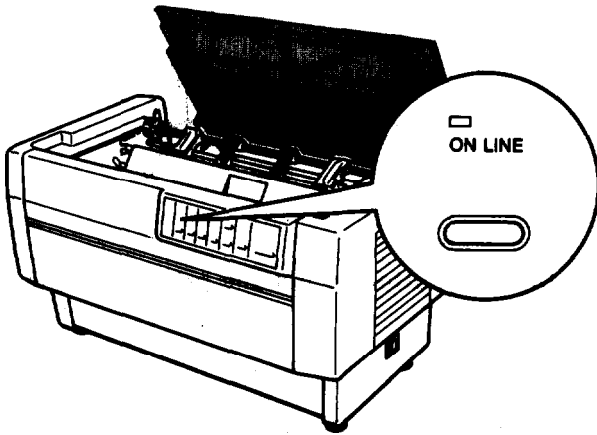

2. Pull the levers on the pull tractor toward you to release the pull tractor.

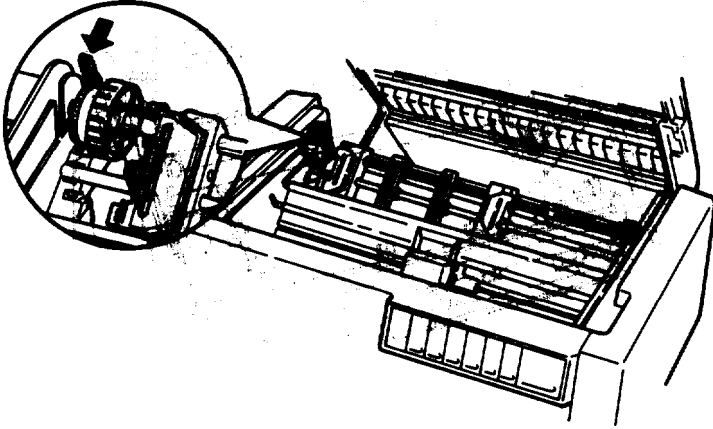

3. Tilt the **tractor** forward with the front notches over the mounting shaft so that its sprocket pins rest on the **metal** frame of the printer.

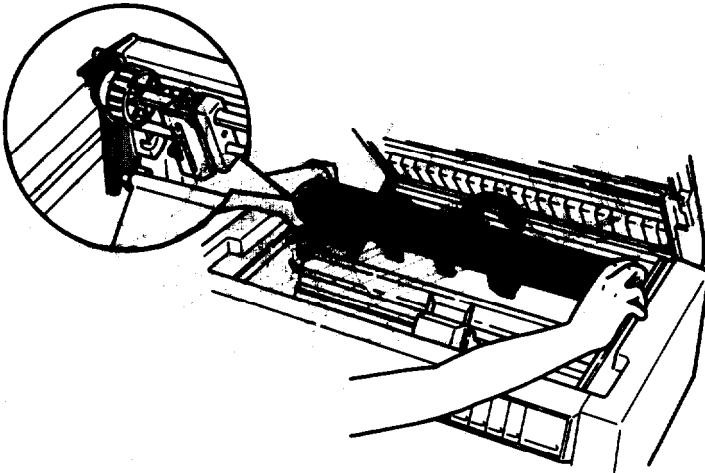

Pull Tractor

4. **Load paper** onto the **rear tractor** as described on page 2-11.

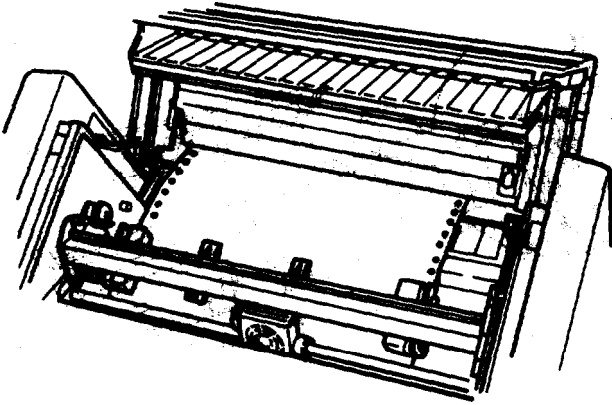

5. Open the paper bail **using** the tab on its right side. Then tilt the pull tractor back until the rear latches click into place over the printer's rear mounting pins.

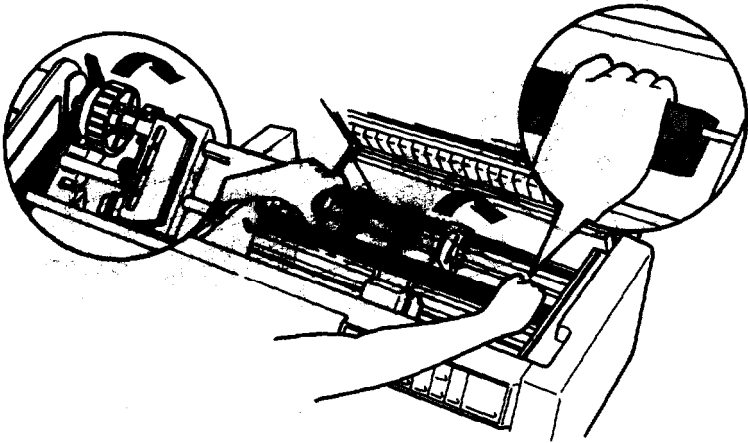

6. Follow steps 3 through 12 in the previous section to load the paper onto the pull tractor.

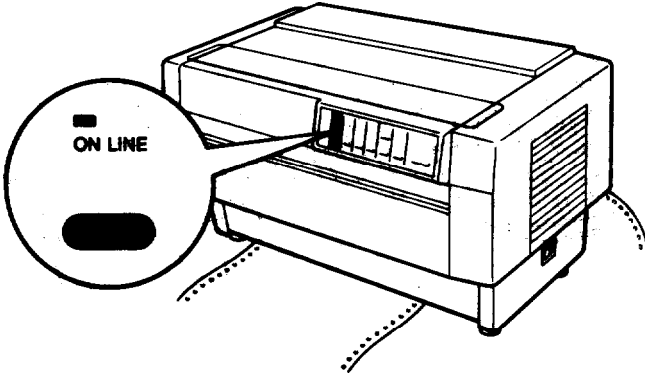

Removing the pull tractor

Follow these steps to remove the pull tractor. You will need a cross-head **screwdriver** and the paper separator that **originally** was installed on the printer.

1. Turn off the printer. Then open the top cover and remove any paper loaded on the pull tractor.

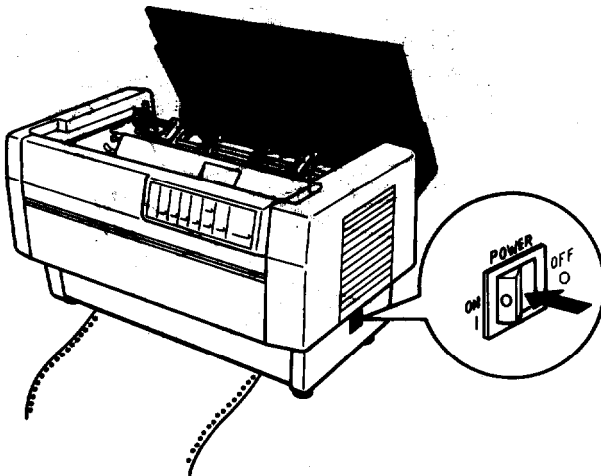

Pull Tractor

2. Pull the levers on the pull tractor forward to release the pull tractor.

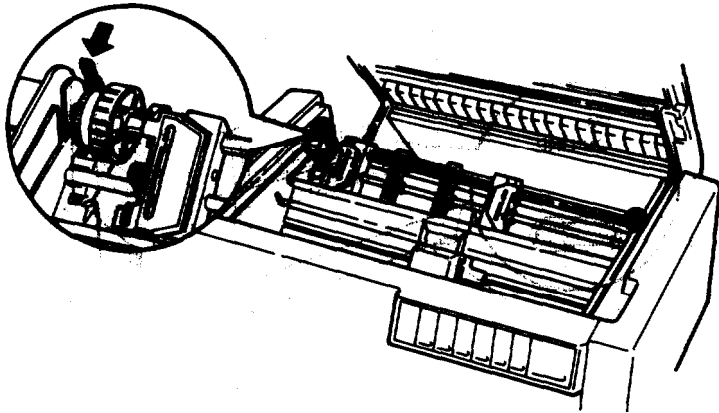

3. Tilt the **pull** tractor forward, and then lift it up and out of the printer.

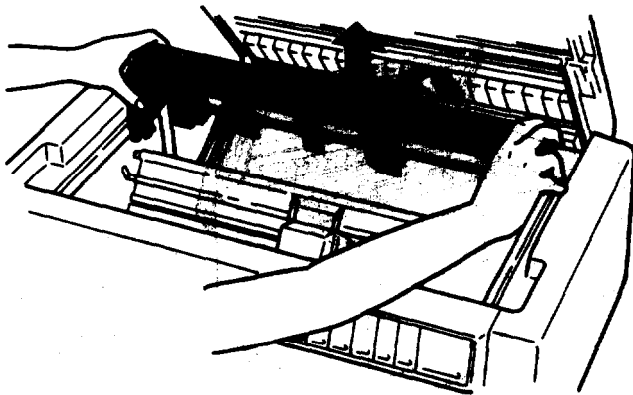

4. **Close** the top cover and **open** the paper separator cover.

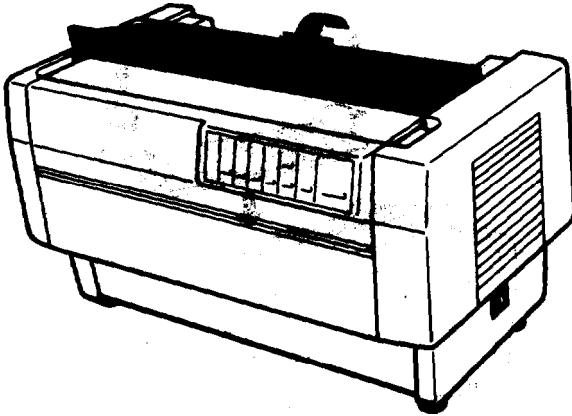

5. **Using** a cross-head screwdriver, remove the paper separator that came with the pull tractor.

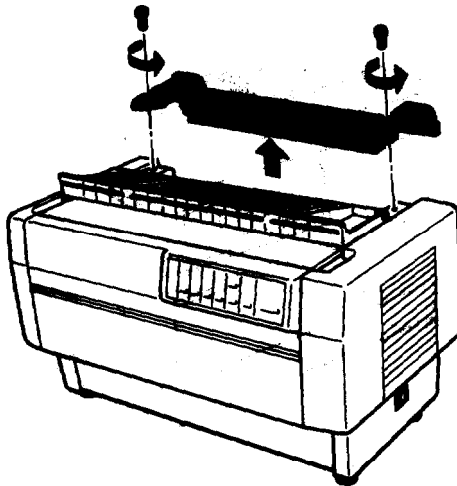

Pull **Tractor**

- Using the two screws you just removed from the paper separator that came with the pull tractor, reinstall the **original** paper separator.

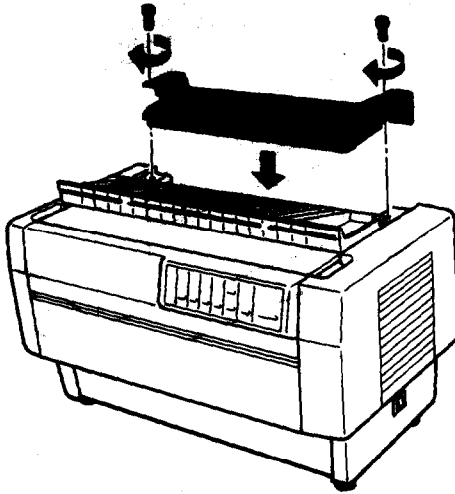

- Close the paper separator cover.

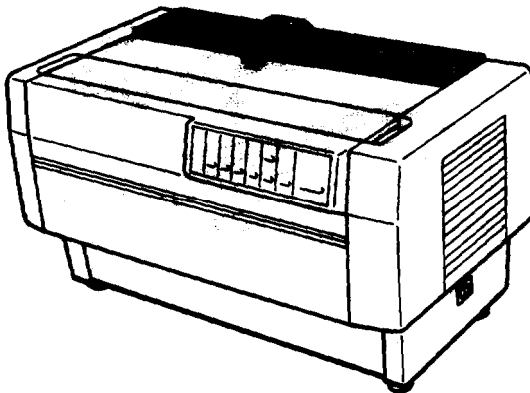

Paper Cutter

The optional paper cutter (C815001) makes using continuous paper easier by cutting off your printed documents for you. When you use the paper cutter, be sure to set the **page length** to match your paper.

Installing the paper cutter

The steps below show you how to install the paper cutter. You will need a cross-head screwdriver.



WARNING: Do not use multi-part forms that vary in thickness with the optional paper cutter. These forms include forms with labels on them and forms that overlap slightly where they are glued together.

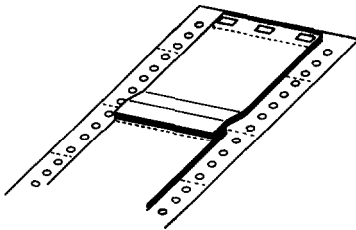

overlapping multi-part forms

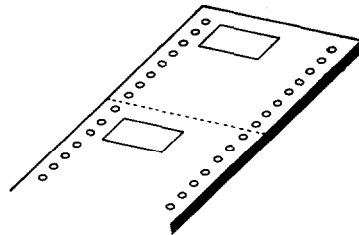

multi-part forms with labels

Note: If you plan to use the paper cutter with the built-in rear tractor, it is best to load paper onto the rear tractor before you install the paper cutter. See the section on loading paper onto the rear tractor in Chapter 2.

Paper Cutter

1. Turn off the printer and open the paper separator cover.

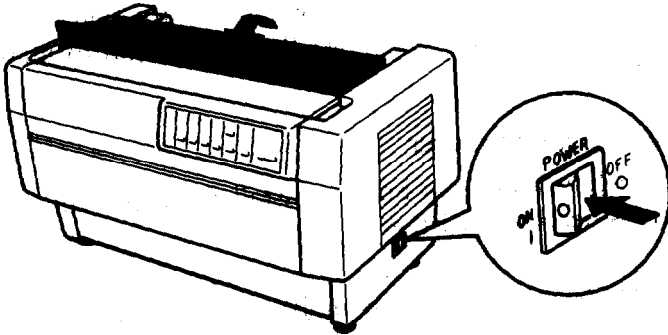

2. Use a cross-head screwdriver to remove the two screws securing the paper separator to the printer. Then lift off the paper separator. Store the paper separator and screws for your later **use**.

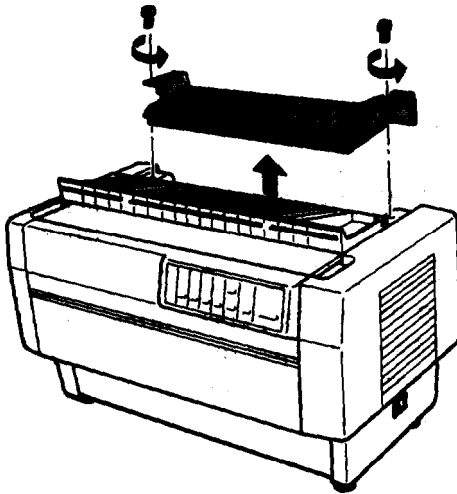

3. Close the paper separator cover and open the top cover.
4. Hold the paper cutter by its handle with the connector facing to the right. Then lower the paper cutter into the space at the back of the printer, guiding the pins on the sides of the paper cutter into the notches in the printer.

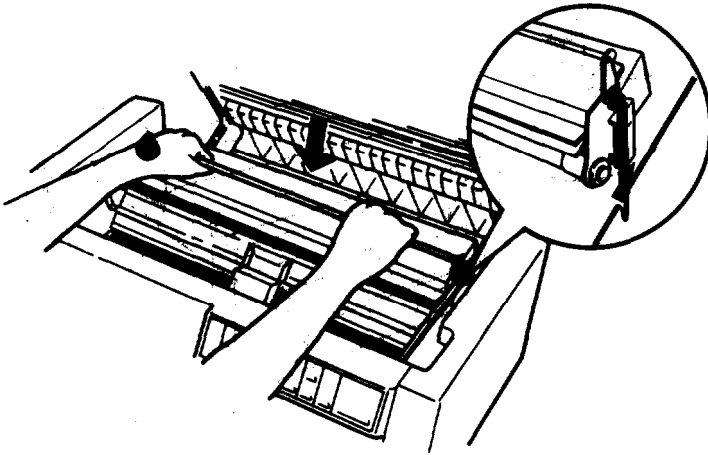

5. After the paper cutter is in place, tilt the paper cutter handle forward. Then close the top cover.

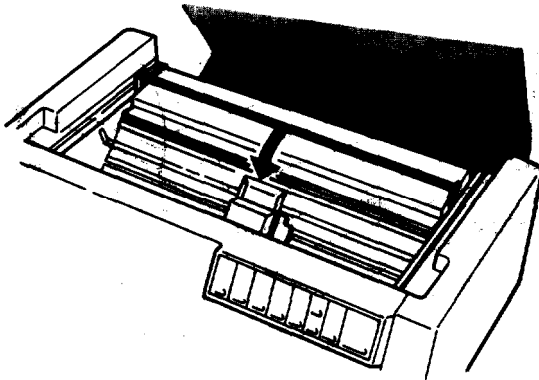

6. Open the rear **flap and remove** it by lifting up to pull the pegs on the rear flap out of the notches at the back of the printer. Then plug the paper cutter's connector securely into the connector inside the printer.

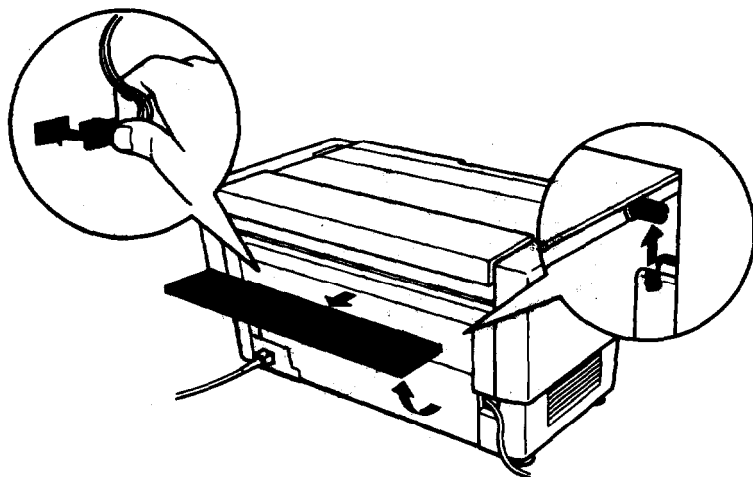

7. To replace the rear flap, fit the pegs on the rear flap into the notches **at the back of the printer**. Then **close** the rear flap.

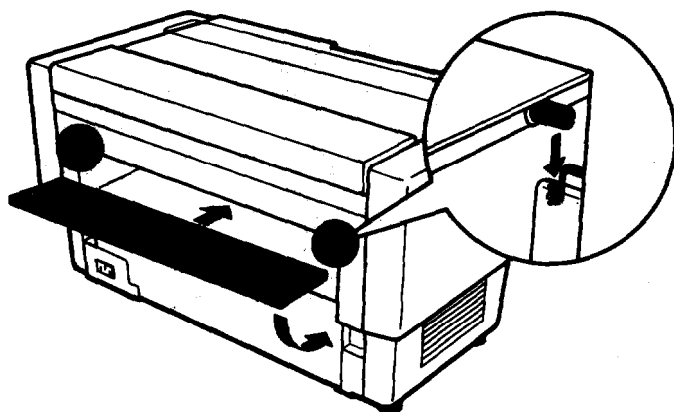

Paper handling

This section describes how to use the paper cutter with your continuous paper. When you use the paper cutter, you need to set the page length to match your paper.

Cutting off a printed document

To cut off a printed document, follow the steps below:

1. Be sure that the printer is turned on and that it is off line.

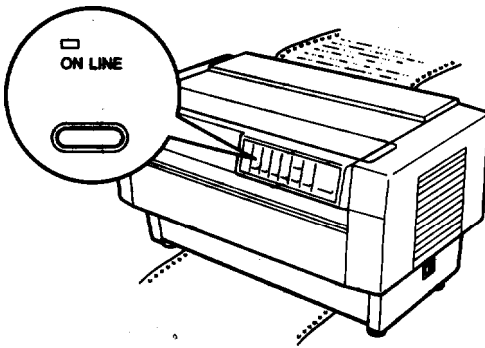

2. Press the TEAR OFF button. The printer advances the paper so that the perforation at the end of the last printed page is near the cutting line of the paper cutter.

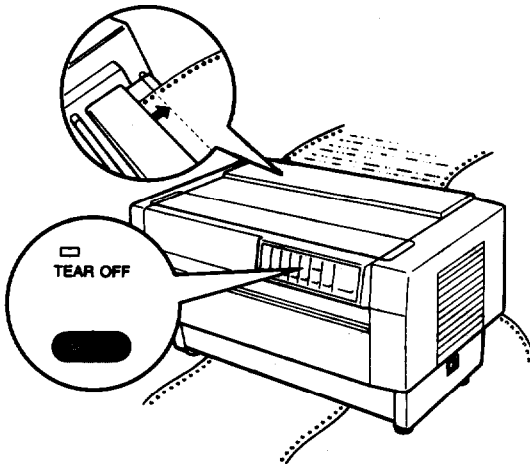

3. If you loaded new paper onto the current tractor since the **last** time you cut off a document, you may need to adjust the cutting position. Open the paper separator cover and use the **MICRO FEED** buttons to adjust the cutting position with the cutting line. Then close the paper separator cover.

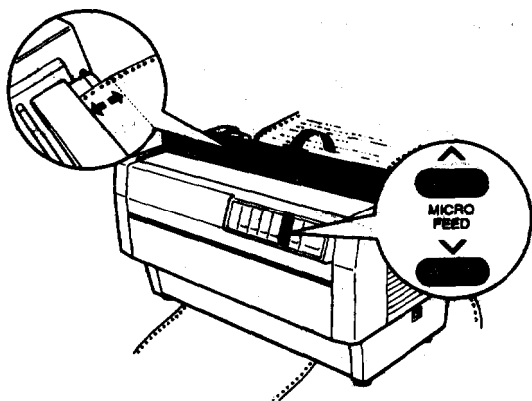

Note: **You can** set the cutting position, from **0.1 inches (3.0 mm)** to **1.0 inches (25.4 mm)** below the perforation at the end of the last printed page. The factory setting of the cutting position is the **0.1 inches (3.0 mm)** position below the perforation;

4. Press the **TEAR OFF** button. The printer cuts off your printed document and feeds the fresh paper back to the top of form position.

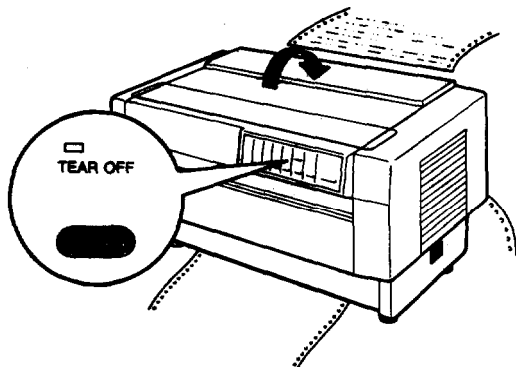

5. Press the ON LINE button to put the printer on line so that it is **ready** to print.

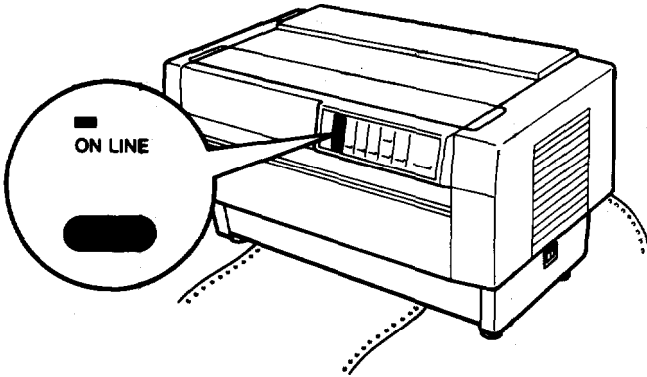

Note: The next printing position after cutting the paper depends on the cutting position and the top of form position, as described below.

When the cutting position is above the top of form position, the printer starts printing at the top of form position on the same page.

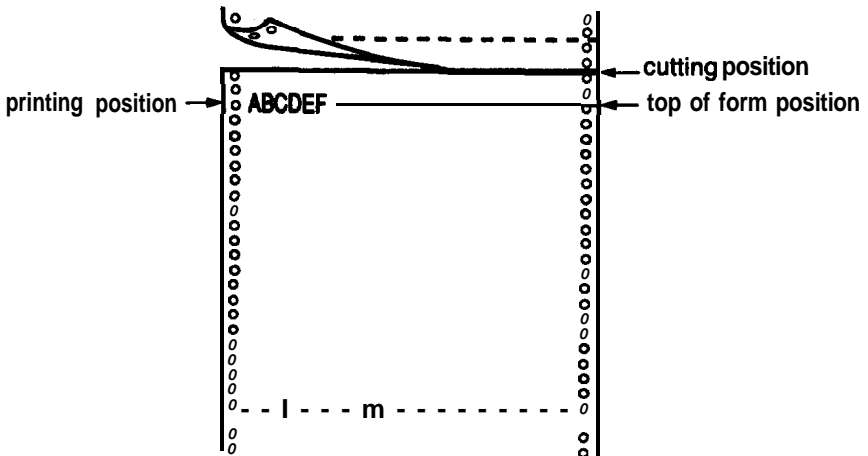

When the cutting position is below the top of form position, the printer starts printing at the top of form position on the next page.

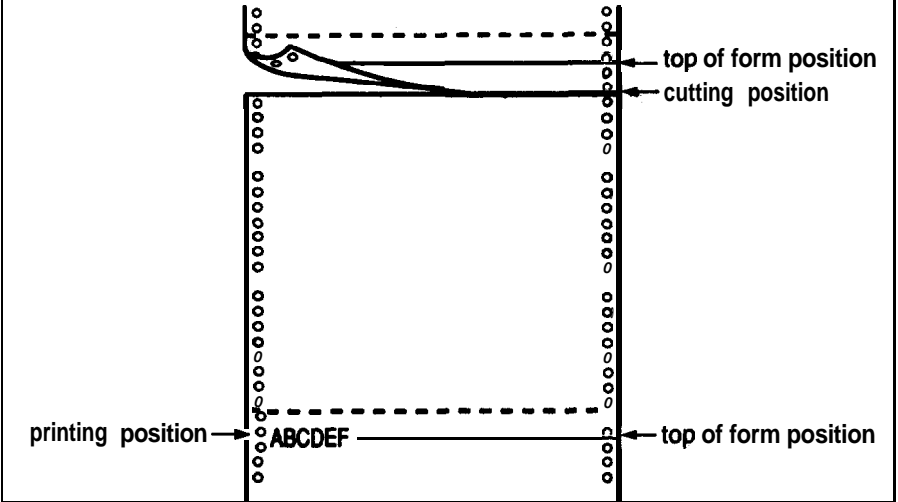

Switching tractors

To switch tractors when the paper cutter is installed, **follow** the steps below:

1. Be sure that the printer is turned on and that it is off line.

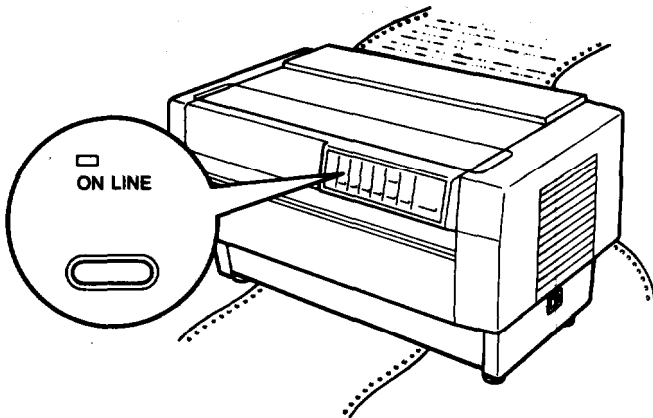

2. Press the **FRONT/REAR** button to switch to the other tractor. The printer cuts off the printed document, feeds the paper on the tractor backward to the standby position, and then advances the paper on the other tractor to the loading position.

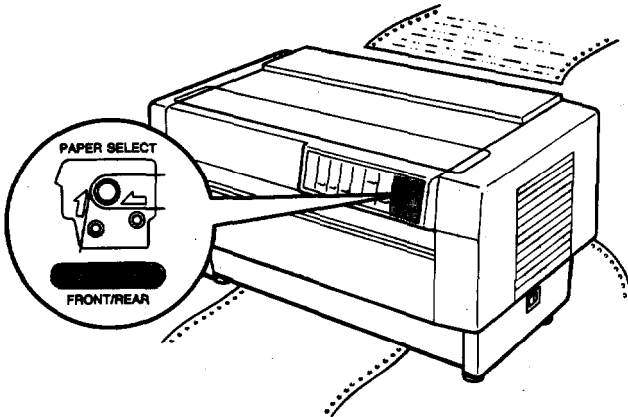

3. Press the **ON LINE** button to put the printer on line so that it is ready to print.

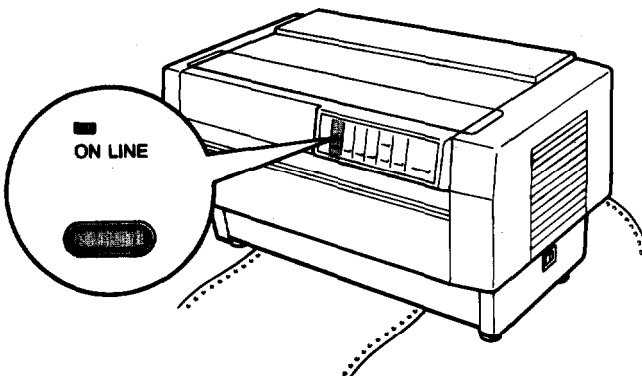

Note: You can use the ESC EM printer command to change tractors only when the paper cutter is installed. For more information about this command, see the Command Summary in Chapter 9.



CAUTION: When you load paper on the tractor, be sure that the first page is tom off exactly at the perforation, and the first four holes in the paper fit over the sprocket unit pins.

Removing the paper cutter

To remove the paper cutter, follow the steps below. After you remove the paper cutter, store it in its original box and packing materials.

1. Cut off any printed document in the printer as described in the section above on cutting off a printed document.

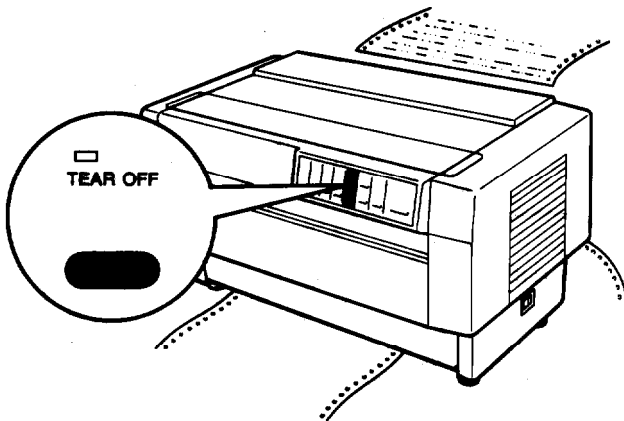

2. Turn off the printer.

3. Open the rear flap and remove it by lifting up to pull the pegs on the rear flap out of the notches at the back of the printer. Then unplug the paper cutter's connector from the printer.

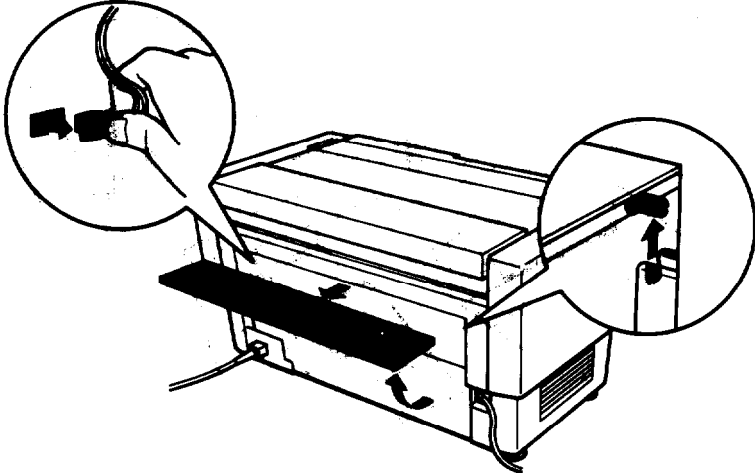

4. To replace the rear flap, fit the pegs on the rear flap into the notches at the back of the printer. Then close the rear flap.

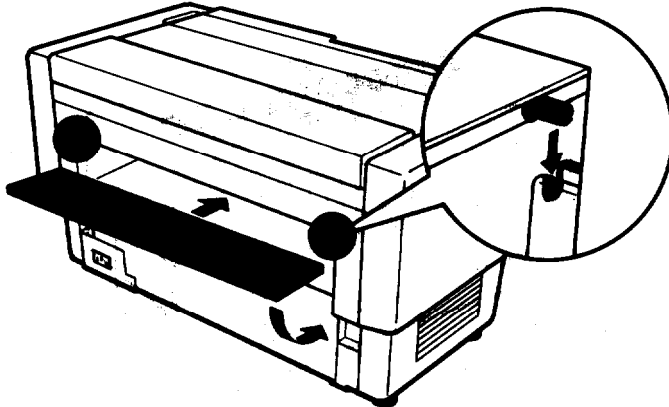

Paper Cutter

5. Open the top cover. Grasp the handle on the paper cutter and lift the paper cutter up and out of the printer.

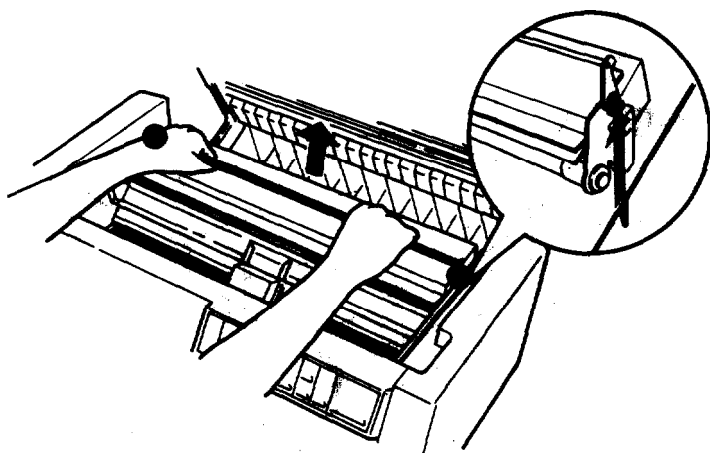

6. Close the top cover and open the paper separator cover.

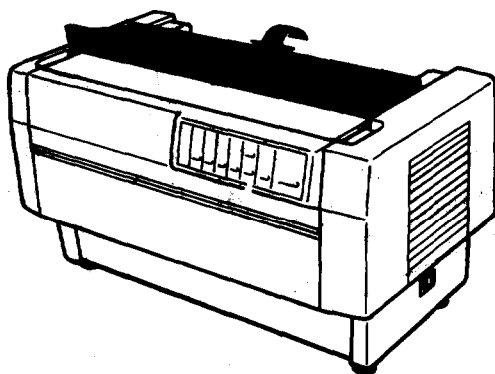

7. Using a cross-head screwdriver, reattach the paper separator.

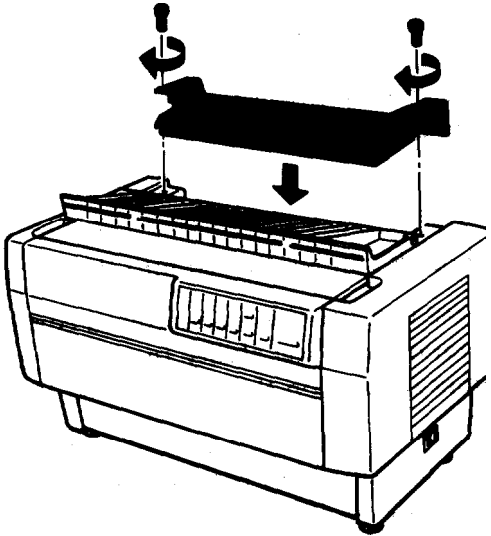

8. Close the paper separator cover.

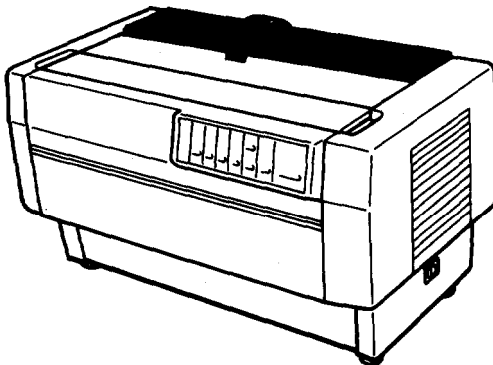

Interface Boards

You can use optional interface boards to supplement your printer's built-in serial and parallel interfaces. If **you don't** know whether you need an **optional interface** or if you want to know more about interfaces, contact your **Epson** dealer,

Choosing an interface

Optional interface boards can be divided into three main categories:

- IEEE-488 interfaces that provide standardized connections, trouble-free operation, and the ability to connect computers, printers, and other devices on the same line so that they can share data freely.
- Coax and twinax interfaces that connect directly to the printer and communicate with **an** IBM minicomputer or mainframe via coax or twinax protocol. These interfaces allow you to use Epson printers as local IBM printers without adding any other circuitry or components.
- Serial interfaces, which are required only if you need an interface that conforms to the Current Loop standard instead of RS-232C or that provides **X-on/X-off** data communications protocol.

Compatible interfaces

The following table lists Epson interfaces that are compatible with the DFX-8000. Some of these interfaces may not be available in your country or region and some may be no longer available.

Number	Name
#8143	New Serial interface board*
#8148	Intelligent serial interface board
#8165	Intelligent IEEE-488 interface board
	Coax interface board
	Twinax interface board

- For more information on the New Serial interface (#8143), see page 5-39.

All Epson interface boards have the Epson name on them. If there is an identification code on the board, it should be one of the four-digit numbers in the table above.

Installing an interface board

The following steps explain how to install an optional interface board. Before you install an interface board, set the DIP switches or jumpers on the board according to the instructions in your computer and interface **board manuals**.

Note: Before you install an interface board, **be** sure your printer's DIP switches are set for use with a parallel interface, even if you are installing a serial interface board. **See** the section on setting the DIP switches in Chapter 3.

Interface Boards

1. Turn off both your printer and computer.

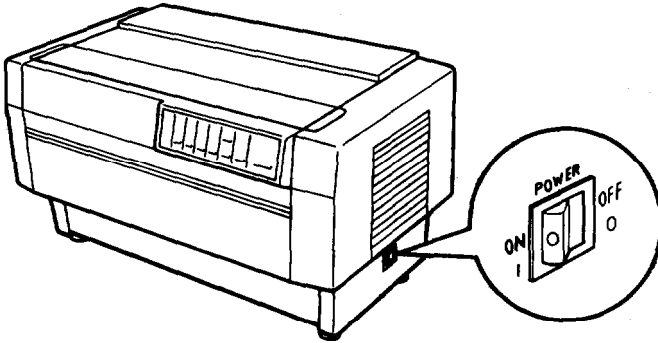

2. Open the rear cover.

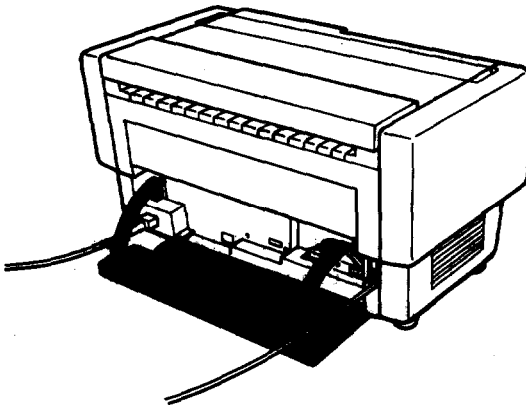

3. Disconnect the printer cable from the printer and the computer. Then unplug the power cable from the electrical outlet and from the back of the printer.

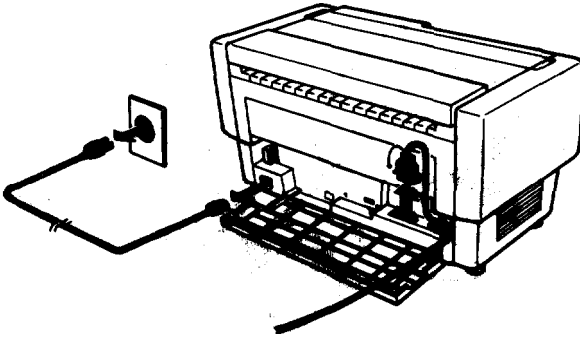

CAUTION: When you install an optional interface board, be sure to disconnect the printer cable from the printer's built-in parallel or serial interface. Two printer cables must not be connected at the same time.

4. If the interface board comes with an FG (frame ground) wire that is not already attached to the board, attach the wire as shown below on the right.

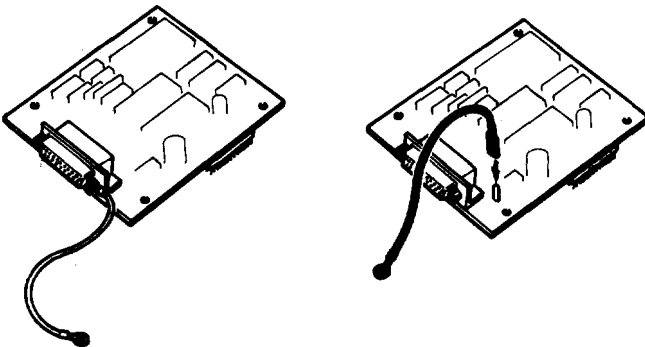

5. **Plug** the cable's connector securely into the interface board. If the connector has tightening screws, use a screwdriver to secure the cable to the interface board. If the connector has clamps instead, squeeze them together to secure the cable to the interface board.

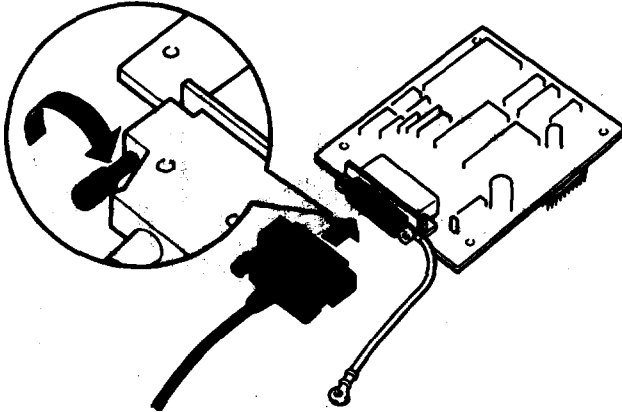

Note: If the cable's connector does not have tightening screws, you do not need to plug the connector into the board before you install it.

6. Place the board in the option slot at the back of the printer, carefully inserting the interface board's pins into the option slot's mating connector.

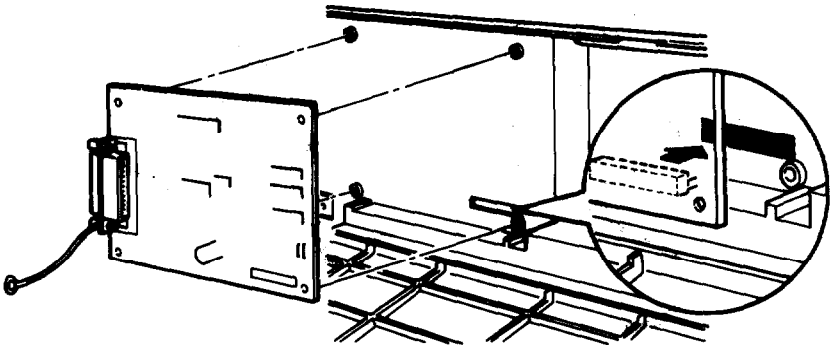

7. Use a cross-head screwdriver to secure the board with the four screws.

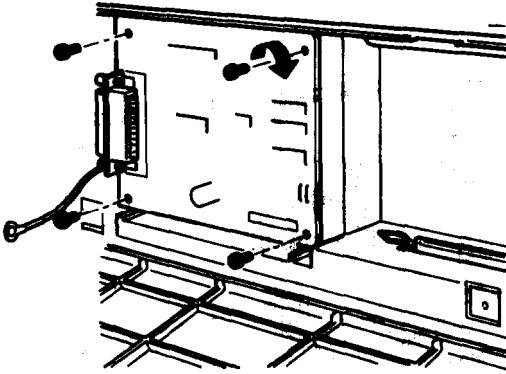

8. Remove the screw from the CG (chassis ground) connector on the printer. Then use the cross-head screwdriver to connect the round end of the FG wire from the interface board to the CG connector.

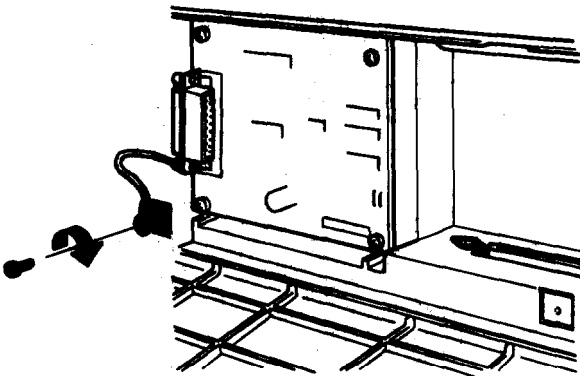

interface Boards

9. Plug a suitable cable securely into the interface board, if you have not done so already. (If the cable connector has screws, you need to plug the cable into the board before you install the board. See step 5 on page 5-36.)

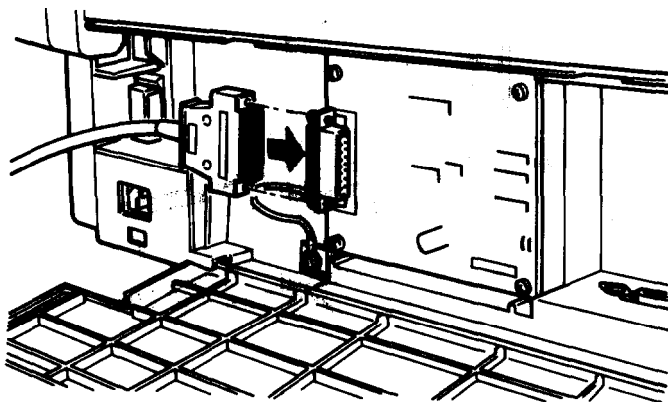

10. Secure the cable using the plastic clamp on the left.

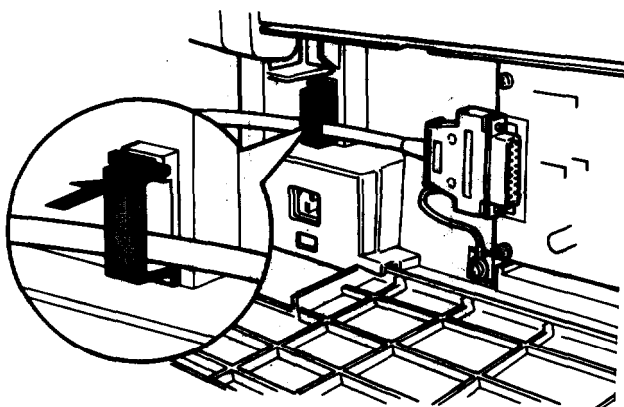

11. Close the rear cover.

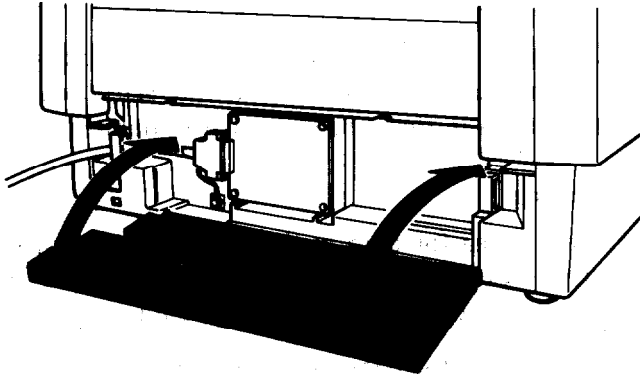

CAUTION: Always be sure the rear cover is closed when you use the printer.

#8143 New Serial interface board

If you use an optional interface, you may need to change the communications protocol of the printer or the computer so that they can communicate properly. In most cases, you should see your optional interface manual or computer manual to match the computer with the interface.

To use the **#8143** interface board with the DFX-8000, see the sections below on selecting a baud rate, handshake timing, and error handling. For all other data transfer conventions, such as word structure and communications protocol, see the **#8143** optional interface board manual,

interface Boards

Selecting a baud rate

The range of baud rate settings for the #8143 interface depends on whether your printer's input buffer is on or off.

You can select baud rates from 75 to 19,200 bps (bits per second). When you set the baud rate, use the bit rate selection table for printers with buffers in the #8143 interface manual.

Handshake timing

When the vacant area for data in the input buffer **drops** to 512 bytes, the printer outputs **an X-OFF** code or sets the DTR flag to **"1"** (MARK) to indicate that it **cannot receive** data.

When the vacant area for data in the buffer increases to 784 bytes, the printer outputs an X-ON code or sets the DTR flag to **"0"** (SPACE) to indicate that it is ready to receive data.

Error handling

When the printer detects a parity error, it prints an asterisk (*). The printer ignores all other errors, including framing and overrun errors.

Chapter 6

Maintenance

Cleaning the Printer	6-2
Replacing the Ribbon.....	6-4
Transporting the Printer.....	6-9

Cleaning the Printer

To keep your printer operating at its best, you should clean it thoroughly several times a year.

The following steps show you how to clean the printer.

1. Turn off the printer and close all of its covers.

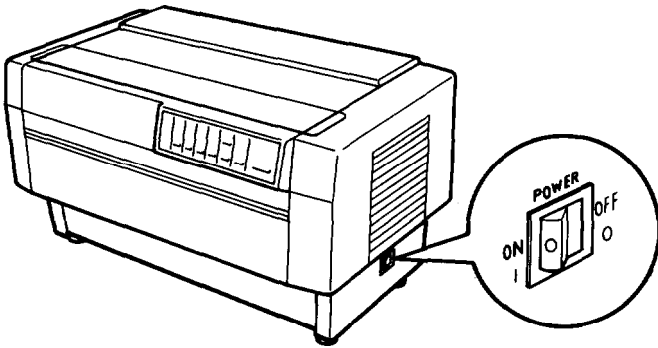

2. Using a soft brush, carefully remove all dust and dirt.

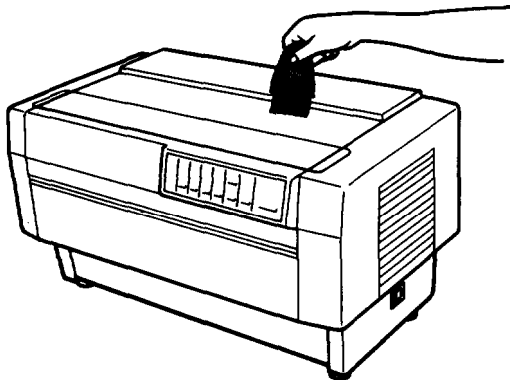

3. If the outer case is dirty or dusty, clean it with a soft, clean cloth dampened with mild detergent dissolved in water. Keep all of the covers closed to prevent water from getting inside the printer.

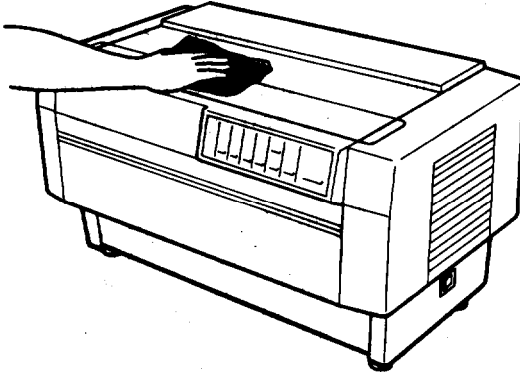

WARNINGS:

- Never use alcohols or thinners to clean the printer. These chemicals can damage the printer components as well as the case.
- Be careful not to get the printer mechanism or electronic components wet.
- Do not use a hard or abrasive brush.
- Do not spray the inside of the printer with lubricants. Unsuitable oils can damage the mechanism. Contact your Epson dealer if you think lubrication is needed.

Replacing the Ribbon

When your printing becomes too faint, you need to replace the ribbon. Use only the #8766 standard Epson replacement ribbon cartridge for the DFX-8000.

The steps below show you how to replace the ribbon.

1. If the printer is on line, press the **ON LINE** button to take it off line. Then turn off the printer and open the top cover.

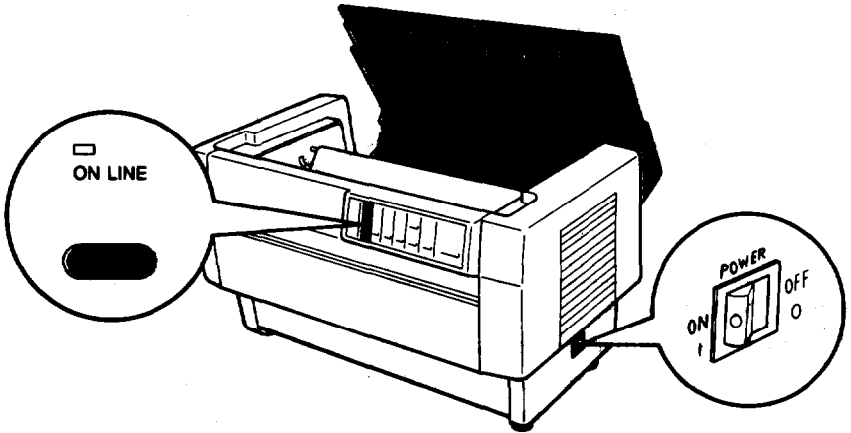

Note: Make sure that the printer is off line before you turn it off. When you take the printer off line, the gap between the print head and the platen widens, making it easier for you to replace the ribbon.

2. Slide the print head to the exposed part of the paper bail, as shown below. Lift the ribbon guide off the print head.

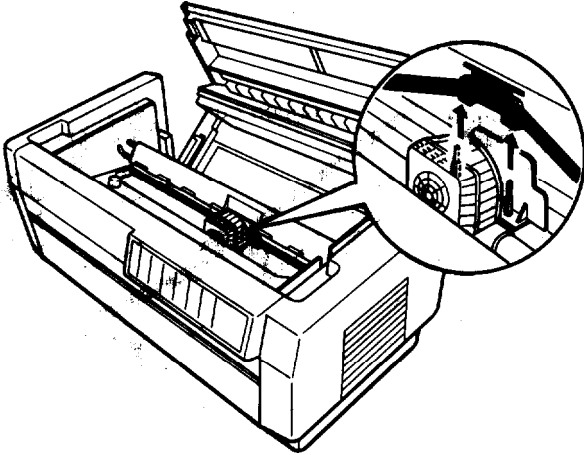

3. Pull up on the inside edge of the ribbon **cartridge** to release it from the printer's mounting pins. Then remove the cartridge by lifting it up and away from you.

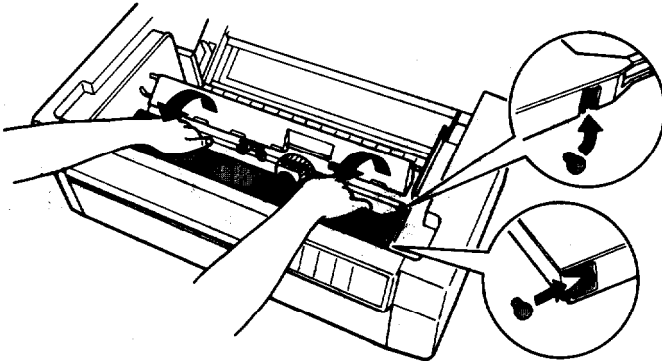

CAUTION: Be sure not to pull on the flat cable beneath the ribbon cartridge when you remove the **cartridge**.

Replacing the Ribbon

4. After you unpack the new ribbon cartridge, remove the separator from the ribbon cartridge and discard it. Then detach the ribbon guide from its holder on the ribbon cartridge (but not from the ribbon). Turn the ribbon-tightening knob to remove any slack in the ribbon.

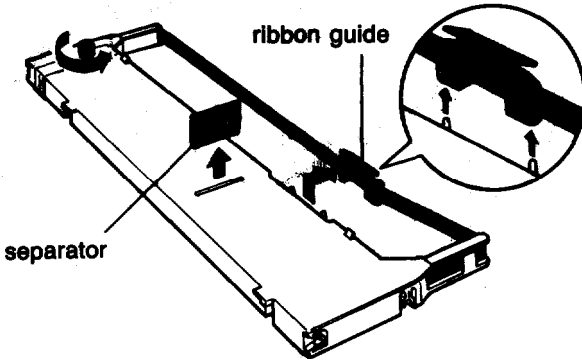

5. Hold the ribbon cartridge with both hands and lower it into the printer. Pulling the cartridge toward you, slide the hooks in the sides of the **cartridge** over the two corresponding pins in the printer. Then push the cartridge down into position so that the remaining two hooks snap into place over the mounting pins in the printer.

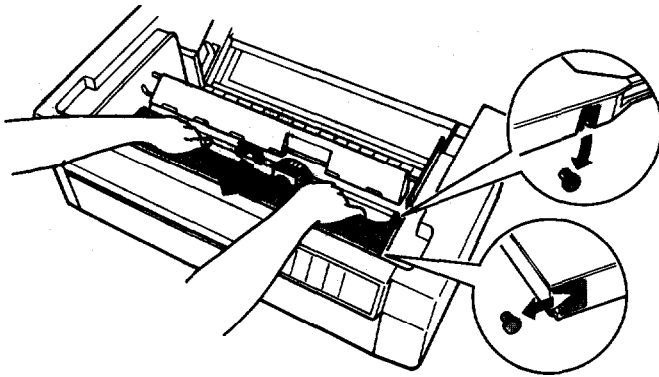

Note: Press lightly on both sides of the cartridge to make sure the hooks **are** properly connected.

6. Fit the plastic ribbon guide onto the metal pins on each side of the print head. The smaller end of the guide should be on top, with its angled edge toward the platen. Turn the ribbon-tightening knob to remove any slack in the ribbon.

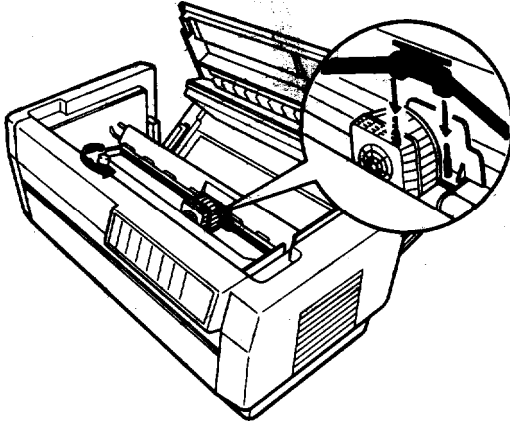

7. Slide the print head from side to side to make sure that it moves smoothly. Also check that the ribbon is not twisted or creased.

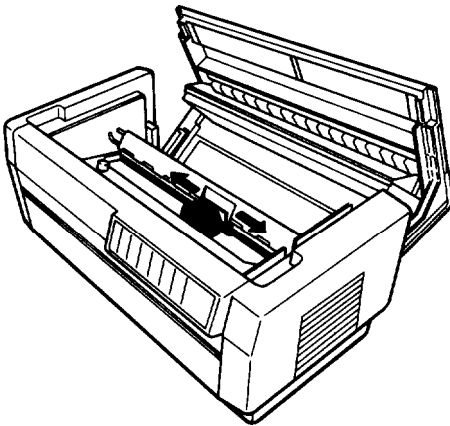

Replacing the Ribbon

8. Close the top cover.

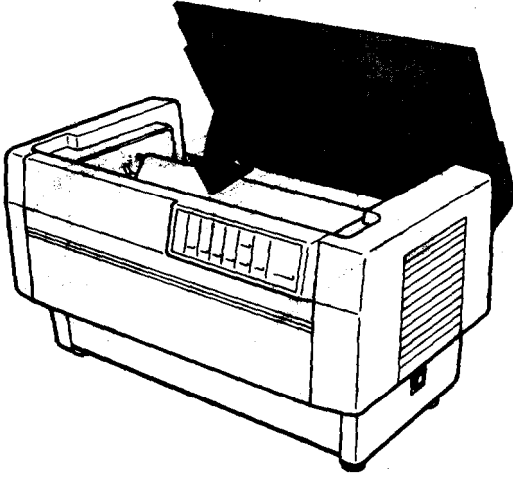

Transporting the Printer

If you need to transport your printer some distance, carefully pack it in the original box and packing materials. The steps below show you how to pack your printer.

1. Turn off the printer and remove any paper loaded in the printer. If any printer options are installed, remove them as described in Chapter 5.

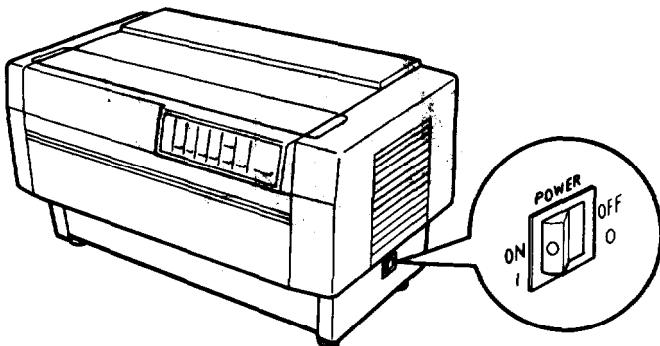

WARNING: Be sure to turn off the printer before you unplug the power cable in the next step.

2. Unplug the power cable from the electrical outlet and then from the back of the printer. Then coil the cable and tie it.

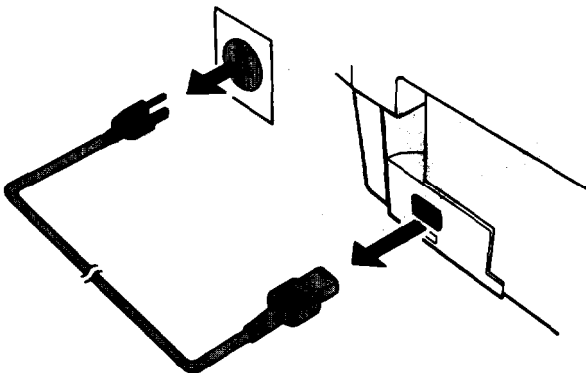

Transporting the Printer

3. Open the rear cover and disconnect the interface cable from the printer and the computer.

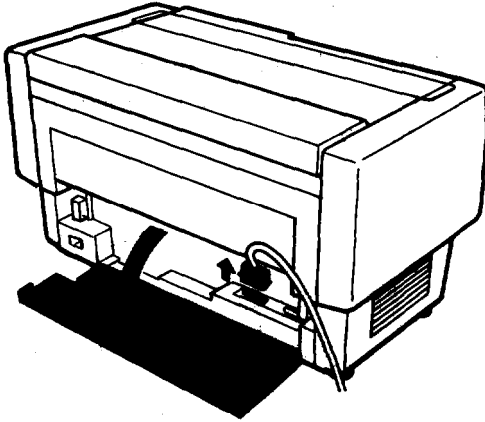

4. Close the rear cover.

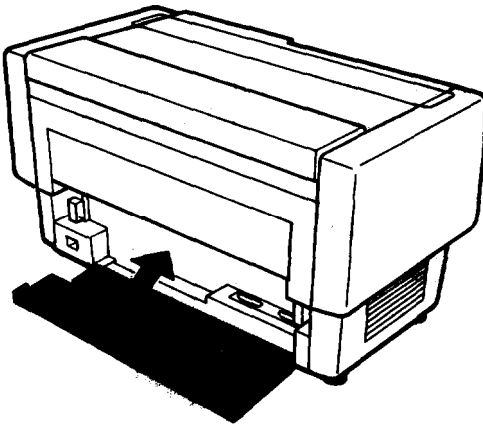

5. Open the top cover and slide the print head to the exposed part of the paper bail, as shown below. Lift the ribbon guide off the print head, and then remove the ribbon cartridge.

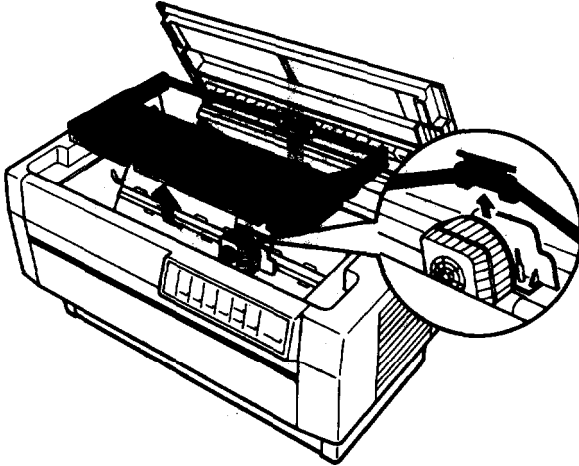

6. Using a cross-head screwdriver, reattach the carriage guide support bar and the two locking brackets.

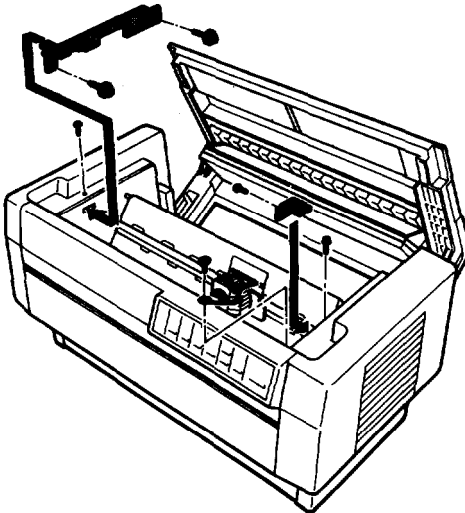

Transporting the Printer

7. Lift up the paper bail and place the piece of foam packing underneath it, as shown below. Then insert the plastic print head protector.

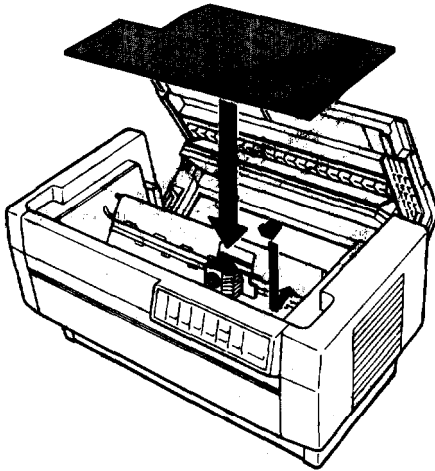

8. Close the top cover.
9. Replace the packing materials and put the printer in its box.



WARNING: Even when you need to carry the printer only a short distance, do not carry it by **yourself**. The printer should always be carried by two people holding the printer at the bottom.

Chapter 7

Troubleshooting

Problems and Solutions 7-2

Power Supply 7-3

Printing..... 7-4

Paper Handling 7-13

Options 7-18



Problems and Solutions

This chapter describes potential problems and their likely solutions. If you encounter a problem, look for it in the list below and see the appropriate page for the solution.

Power supply

- Power is not being supplied to the printer. See page 7-3.

Printing

- The printer does not print. See page 7-4.
- The printout is faint. See page 7-6.
- Parts of printed characters or graphics are missing. See page 7-6.
- Printed characters are not what you expect. See page 7-7.
- The printing position is incorrect. See page 7-9.

Paper handling

- The printer does not feed continuous paper properly. See page 7-13.
- The printer does not switch tractors properly. See page 7-17.

Options

- A pull tractor is installed and the printer does not feed continuous paper properly. See page 7-18.
- A paper cutter is installed and the printer does not feed continuous paper properly. See page 7-20.
- An optional interface board is installed and the printer does not work properly. See page 7-23.

Power Supply

Problem

Solution

Power is not being supplied to the printer.

The POWER light does not go on.

The power cable may not be fully plugged into the printer or the electrical outlet. Turn off the printer and see that **the** cable is fully plugged into the printer and the electrical outlet.

The power switch is off. Turn on the switch.

The electrical outlet may not be supplying power. Check if an outside switch or automatic timer controls the **electrical** outlet. **If** so, use a different outlet.

The electrical outlet may not work. Plug another electrical device into the outlet to check whether the outlet works.

The POWER light comes on briefly and then goes off. The light stays off after you turn the printer off and then on again.

The voltage supplied by the electrical outlet may **not be** correct for your printer. Check the label on the printer's rear panel to see if the printer's **voltage** rating matches that of your electrical outlet. If the voltages do not match, unplug the printer and contact your Epson dealer. Do not reconnect the power cable to **an** electrical outlet. See page 1-13.

Printing

You can solve many printing problems, including problems **with** line spacing and margins, by changing your application program's settings. When you encounter a printing problem, check your software settings first. If this does not work, check the printer's DIP switch settings next.

Problem

Solution

The printer does not print.

The ON LINE light is off.

The ON LINE light is on.

The printer may be off line. If so, it cannot receive and print data. Press the **ON LINE** button. The **ON LINE** light should go on. See page 3-3.

Your software may not be set up correctly for the printer. Check your program's printer settings and make any necessary changes. See page 1-36.

The interface cable may be loose. Make sure the printer is connected securely to the computer. If you are using a parallel interface, secure the connector with the wire retaining clips. If you **are using a** serial interface with a cable connector that has screws, secure the **cable** connector using the screws. See page 1-26.

You may not be using the correct interface cable. Make sure your interface cable meets the printer and the computer specifications. See page 8-11.

Problem**Solution**

The PAPER OUT light is on.

The printer's interface DIP switch settings may not be correct. Check DIP switches 2-5, 2-6, 2-7, and 2-8, and reset them if necessary. See page 3-13.

The printer beeps four times and stops printing and the ON LINE light goes off,

The printer may be out of paper. If so, load paper. Be sure the paper is properly loaded onto the printer's sprocket pins. See pages 2-4 and 2-11.

The printer sounds like it is printing, but nothing is printed.

The top cover may be open. To resume printing, close the top cover and press the ON LINE button.

The printer makes a strange noise, beeps several times, and stops printing.

The ribbon cartridge may not be installed properly. Turn off the printer, reinstall the ribbon cartridge, and take up any slack in the ribbon. See page 1-9.

The ribbon **may be** worn. **Replace** the ribbon **cartridge**. See page 6-4.

The ON LINE light is flickering and the printer does not print.

Your printer is not working properly. Turn off the printer and check for paper jams or other problems. Make sure that all protective materials **are** removed. Then turn on the printer. If the printer still does not print correctly, contact your Epson dealer.

The print head is overheated. Wait several minutes until the printer head cools. Printing resumes when the head cools.

Problem

Solution

The printout is faint.

The printout is faint.

The printing on the last pages of your multi-part forms is faint.

Parts of printed characters or graphics are missing.

The bottom parts of characters are missing, as shown here:

ABCD

A blank line runs through your characters, as shown here:

ABCD

The ribbon may be worn out. A worn ribbon can damage the print head. Install a new ribbon cartridge as soon as possible. See page 6-4.

Use copy mode to print clearer, darker characters on the last pages of your multi-part forms. To select copy mode, press the FORM FEED/COPY button when the ON LINE light is on. The printer beeps twice to indicate it is in copy mode. See page 2-29.

The ribbon cartridge may not be installed properly. Remove the ribbon cartridge and reinstall it. Make sure the cartridge hooks are securely connected to the printer. See page 1-9.

The print head is damaged. Stop printing and contact your Epson dealer to have the print head replaced.

Problem**Solution**

Parts of characters **are missing, as shown here:**

ABCD

Printed characters are not what you expect.

The printer does not print the typestyle or characters set by the software.

You selected the Roman, Sans Serif, or draft font with your software, but characters are printed in a different font.

The printer prints italic characters instead of the graphic and line characters you selected.

There is too much slack in **the** ribbon or the ribbon has caught **on something**. **Stop** printing, turn off the printer, and reinstall the ribbon cartridge. See page **1-9**.

Your software may not be set up correctly for the printer. Use the program's setup (or install) procedure to check the printer settings, and change them if necessary.

The wrong font is selected. If your program accepts control codes, set **the** codes to the values below to select the fonts:

Roman: ESC k 0
 Sans Serif: ESC k 1
 Draft: ESC x 0

See pages 3-43 and 9-23.

The wrong character table is selected. If your application program can send control codes, specify the Epson Extended Graphics character table using ESC t 1.
 See page 9-34.

You can also set a DIP switch to select the graphics character table. To do this, turn off the printer, turn on DIP switch 1-3, and then turn on the printer. See page 3-49.

Problem

Solution

Printed characters are not what you expect (continued).

The printer prints graphic characters or lines instead of the italic characters you selected.

The wrong character table is selected. If your application program can send control codes, specify the italic character table using ESC t 0. See page 9-34.

You can also set a DIP switch to select the italic character table. To do this, turn off the printer, turn off DIP switch 1-3, and then turn on the printer. See page 3-49.

The wrong international characters are printed.

The wrong international character set is selected. If your application program can send control codes, specify the desired international character set using ESC R n. See page 9-34.

You can also set a DIP **switch** to select **an** international character set. To do this, turn off the printer, set DIP switches 1-6, 1-7, and 1-8 to select the character set you want, and then turn on the printer. **See** page 3-47.

Printed characters are smaller than you expect.

Condensed mode may be selected. If your application program can send control codes, cancel condensed mode using DC2. See page 9-26.

Problem

Solution.

A series of strange characters is being printed.

You can also set a DIP switch to cancel condensed mode. To do this, turn off the printer, turn off DIP switch 1-1, and then turn on the printer. See page 3-46.

The printing position is incorrect.

Your printer and computer may not be communicating correctly. Make sure that you are using the correct interface cable, that the communication protocol is correct, and that the interface cable is securely plugged in. See pages 3-13 and g-11. See your computer manual for more information.

Printing starts too high or too low on the page.

The top of form position may be incorrect. Adjust the top of form position as described on page 3-33. If the problem persists, check your software program's top margin setting and change it if necessary.

The line spacing is incorrect.

If your application program can send control codes, set the line spacing using **ESC 0**, **ESC 1**, **ESC 2**, **ESC 3**, or **ESC A**. See pages 9-15, 9-16, and 9-17.

One line of printing takes up two lines.

The margins may not be set correctly. If your application program can send control codes, set the left and right margins using **ESC 1** or **ESC Q**. See pages 9-19 and 9-20.

Problem

Solution

The printing position is incorrect (continued).

In BASIC, enter one of the following statements:

WIDTH LPRINT 255

or

WIDTH "LPT1:", 255

If the printer still does not print properly, set the right margin to the maximum setting **using** ESC Q.

All the text is printed on the same line.

A line feed signal is **not** being sent at the end of **each** line. Turn on DIP switch 2-4 so that the printer adds **a** line feed code to each carriage return sent by the application program. See page 3-15.

The printer inserts extra blank lines between lines of text.

Extra line feed signals are being sent. Turn off DIP switch 2-4. See page 3-15.

The page length does not match the length of the paper.

The **page** length may be set incorrectly. Check your application program's page length setting and change it if necessary. You can also turn off DIP switch 3-2 to set the page length to 11 inches (279.4 mm) or turn on the switch to set the **page** length to 12 inches (304.8 mm). See page 3-17. If your application program can send control codes to the printer, you can set the page size using ESC C or ESC C 0.

Problem	Solution
<i>The printout contains regular gaps.</i>	One inch skip over perforation may be set. Turn off DIP switch 3-3. If your application program allows you to use control codes, cancel skip over perforation using ESC O. See page 3-18.
<i>Skip over perforation is set, but the perforation does not fall in the center of the skip.</i>	The page length may be set incorrectly. Set DIP switch 3-2 to match your paper length. See page 3-17. If your application program allows you to use control codes, you can set the page length using ESC C or ESC C 0. See pages 9-13 and 9-14. The top of form position may be too high or too low. Adjust the top of form position so that the perforation is centered within the skip area. See page 3-33. Your application program may be setting the top and bottom margins. If so, turn off DIP switch 3-3 to cancel skip over perforation. See page 3-18.
<i>Vertical printed lines are not aligned.</i>	The printer may be set for bidirectional printing. This can cause a slight misalignment of graphics characters. If you need to print precisely aligned vertical lines, select unidirectional print mode by sending ESC U or ESC < to the printer. See page 9-10.

Note: If you are still having **printing problems** after trying the solutions in this section, you can use data dump mode. This mode helps advanced users find the cause of communication problems **between the printer and application** programs. In data **dump** mode, the printer produces an exact printout of the codes reaching the printer. See the section on data dump mode in Chapter 3.

If the printer still does not print correctly, try the self test described in Chapter 1. If **the self test works properly**, the printer is all right, **and the problem probably** lies in the computer, **the software**, or **the cable**. If the self test does not work, contact your Epson dealer.

Paper Handling

This section describes potential problems with handling continuous paper and their likely solutions. If you have problems using the optional pull tractor or paper cutter, see the section on options on page 7-18.

Problem

The printer does not feed continuous paper properly.

When you press the LINE FEED/LOAD button, the printer does not feed the paper.

Solution

The printer may be on line. If the **ON LINE** indicator is lit, press the **ON LINE** button to take the printer off line, and **then try to** feed the paper. After you feed the paper, press the **ON LINE** button again to put the printer on line. See page 3-3.

The wrong tractor may be selected. Check if the correct tractor arrow is lit on the **PAPER SELECT** indicator. If the wrong tractor is selected; be sure paper is loaded to the **standby** position on the tractor you **want to** use. Then press the **FRONT/REAR** button to switch to that tractor. See pages 2-9 and 2-18.

The printer may be out of paper. Load paper onto the tractor. The tractor arrow on the **PAPER SELECT** indicator should be green. See pages 2-4 and 2-11.

Problem

Solution

The printer does not feed continuous paper properly (continued).

The paper jams or does not feed smoothly into the printer.

There may be some obstacle, such as a cable, in the way of the paper or something on top of the paper supply. See page 2-2

The paper supply may be too far from the printer. Position your paper supply within 3.28 feet (1 meter) of the printer.

The paper supply may not be aligned with the front or rear tractor. See page 2-3.

The rear cover **may** be open. Close the rear cover before trying to feed the paper.

The paper may be caught on the paper separator. Be sure the edge of the first page emerges below the paper separator.

The paper may not be mounted on the sprockets correctly. Check the paper on the sprockets to be sure the paper's sprocket holes fit correctly over the sprockets. Be sure the paper on the sprockets is not ripped or jammed. If something is wrong with the paper, tear off the paper below the tractor and press the FORM FEED button to eject the remaining paper. Then load fresh paper, making sure the first sheet has a clean, straight edge.

The holes on the sides of the paper may not be aligned with each other. Reposition the paper on the tractor pins. See pages 2-7 and 2-16.

Problem**Solution**

The printout contains regular gaps.

Skip over perforation does not work.

The sprocket units may not be positioned for the width of your paper. Move the right sprocket unit to the right to remove any slack in the paper, or to the left to remove any excess tension in the paper. See pages 2-8 and 2-17.

The sprocket covers may be open or the sprocket lock levers may be unlocked. Close the sprocket covers. Be sure the sprocket units are positioned to match the width of your paper. Then lock them in place by pressing the sprocket lock levers away from you. See pages 2-8 and 2-16.

The paper may not meet the specifications for the DFX-8000. Check that your paper is of the proper size, weight, and thickness. See pages 8-5 and 8-6.

The print head may be catching the binding area of your multi-part forms. Turn on DIP switch 3-7 to select the skip over binding function. See page 3-16.

Skip over perforation may be selected. Turn off DIP switch 3-3. If your application program allows you to use control codes, cancel skip over perforation using ESC O. See pages 3-18 and 9-15.

You may have turned on DIP switch 3-3 when the printer was on. To make any new DIP switch settings effective, turn off the printer and then turn it back on. See page 3-7.

Problem

Solution

The printer does not feed continuous paper properly (continued).

Skip over perforation is set, but the perforation does not fall in the center of the skip.

The top of form position shifts slightly when you print several pages.

Your application program may cancel the **skip** over perforation set by DIP switch 3-3. Check that your application program's settings are correct.

The page length may be set incorrectly. Set DIP switch 3-2 to match your paper length. If your application program allows you to use control codes, you can set the page length using ESC C or ESC C 0. See pages 3-17, 9-13 and 9-14

The top of form position may be too high or too low. Adjust the top of form position so that the perforation is centered within the skip area. See page 3-33.

The paper may be too heavy for the built-in tractor. When you require highly accurate paper feeding such as when you print carbon copies, use the optional pull tractor. See page 5-2.

Problem**Solution**

The printer does not switch tractors properly.

When you press the FRONT/REAR button to switch tractors, the paper jams or the printer does not feed the paper back to the standby position.

When you press the FRONT/REAR button to switch tractors, the printer does not load paper onto the selected tractor.

The printer may have tried to reverse feed too many pages. Use the short tear off feature to tear off the printed document or any excess paper so that the printer needs to reverse feed only one page. Then press the FRONT/REAR button to switch tractors. See page 2-20.

You may be trying to switch tractors when labels are loaded in the printer. **Labels** jam when they are fed backward, so always remove any labels loaded in **the** printer **before** you switch tractors. To remove labels loaded in the printer, tear off the **fresh supply below** the tractor and press the FORM FEED or LINE FEED button to eject the remaining labels. See page 2-32.

The -printer may be out of paper. Load paper onto the tractor. The tractor arrow on the PAPER SELECT indicator should be green. See pages 2-4 and 2-11.

Options

Problem

Solution

A pull tractor is installed and the printer does not feed continuous paper properly.

When you press the FORM FEED or LINE FEED button, the printer does not feed the paper.

The paper jams or does not feed smoothly into the printer.

The printer may be on line. Before you press the FORM FEED or LINE FEED button to feed paper, **be** sure the printer is off line (the ON LINE light is out). See page 3-4.

The pull tractor may **not** be correctly installed. Remove the pull tractor and then reinstall it, making sure the mounting notches and pins fit together properly. See page 5-2.

There may be **some** obstacle, such as a cable, in the way of the paper supply or something on top of the paper supply. See page 2-2.

The paper supply may be too far from the printer. Position the paper supply within 3.28 feet (1 meter) of the printer.

The rear cover may be open. Close the rear cover before trying to feed the paper.

The paper may be caught on the paper separator. Be sure the edge of the first page emerges below the paper separator.

Problem**Solution**

The printout contains regular gaps.

Skip over perforation does not work.

The pull tractor sprockets and the built-in tractor sprockets may not be aligned correctly. Align the pull tractor and built-in tractor sprockets.

The sprocket units may not be positioned for the width of your paper. Move the right **sprocket** unit to the right to remove any slack in the paper or to the left to remove any excess tension in the paper.

The paper may have too much slack along its length. Press in the pull tractor feed knob on the right and **turn** it to remove **any excess slack**. See page 5-9.

The paper may not meet the specifications for the DFX-8000. Check that your paper is of the proper size, weight, and thickness. See pages 8-5 and 8-6.

The print head may be catching the binding area of your multi-part forms. Turn on DIP switch 3-7 to select the skip over binding function. See page 3-16.

Skip over perforation may be set. Turn off DIP switch 3-3. See page 3-18.

You may have turned on DIP switch 3-3 when the printer was on. To make any new DIP switch settings effective, turn off the printer and then turn it back on. See page 3-7.

Problem

Solution

A pull tractor is installed and the printer does not feed continuous paper properly (continued).

Skip over perforation is set, but the perforation does not fall in the center of the skip.

The paper cutter is installed and the printer does not feed continuous paper properly.

When you press the TEAR OFF or FRONTREAR button, the paper cutter does not cut the paper.

Your application program may cancel the skip over perforation set by DIP switch 3-3. Check that your application program's settings are correct.

The page length may be set incorrectly. Set DIP **switch** 3-2 to match your paper length. You **can** also set the page length using ESC C or ESC C 0. See pages 3-17, 9-13, and 9-14.

The top of form position may be too high or too low. Adjust the top of form position so that **the perforation** is centered within the skip area. See page 3-33.

The paper cutter's connector may not be plugged securely into the printer. Turn off the printer. Open the rear flap and check the paper cutter connector. See page 5-22.

Problem

When you press the FORM FEED or LINE FEED button, the printer does not feed the paper.

The paper jams or does not feed smoothly.

solution

The printer may be on **line**. **Before** you press the **FORM FEED** or **LINE FEED** button to feed the paper, be sure **the printer** is off line (the **ON LINE** light is out). See **page 3-4**

The paper cutter may not be correctly **installed**. Remove the paper cutter and then **reinstall** it, making sure the mounting notches and pins fit together properly. See page 5-19.

The paper **cutter** may cut the paper so that the perforation at the end of the last printed page remains with the paper loaded in **the** printer. This perforation may cause a paper **jam**. Use **the MICRO FEED** buttons to **position** the paper so that the perforation at the end of the last printed page is even with or just past the cutting **line**. Be sure to set the page length to match your paper. See page 5-24.

You may be using multi-part forms that vary in thickness with the paper cutter. Multi-part forms that vary in thickness include forms with labels on them and forms that overlap **slightly** where they are glued together. Do not use these forms when the paper cutter is installed. see page 5-19.

There may be some obstacle, such as a cable, in the way of the paper or something on top of the paper supply.

Problem

Solution

The paper cutter is installed and the printer does not feed continuous paper properly (continued).

The paper supply may be too far from the printer. Position the paper supply within 3.28 feet (1 meter) of the printer.

The rear cover may be open. Close the rear cover before trying to feed the paper.

The paper may be caught on the paper separator. Be sure the edge of the first page emerges below the paper separator.

The sprocket units may not be positioned for the width of your paper. Move the right sprocket unit to the right to remove any **slack** in the paper or to the left to remove any excess tension in the paper.

The paper may not meet the specifications for the DFX-8000. Check that your paper is of the proper size, weight, and thickness. **See pages 8-5 and 8-6.**

The print head may be catching the binding area of your multi-part forms. Turn on DIP switch 3-7 to select the skip over binding function. See page **3-16**.

Problem**Solution**

An optional interface board is installed and the printer does not work properly.

The printer does not print or the printout is not what you expect.

The interface board may be loose or not properly connected. Check that the interface board is fully inserted into the connector on the back of the printer. See page 5-33.

You may not be using a compatible interface board. Check if you can use the interface with the DFX-8000. See page 5-33.

You may not be using the correct cable. Be sure the cable matches the interface specifications.

The DIP switches or jumpers on the interface board may not be set correctly. See the interface manual for the correct settings.

The computer and interface settings may not match. See the computer and the interface manual to find the proper settings.

Chapter 8

Technical Specifications

Printer Specifications	8-2
Printing.....	8-2
Paper.....	8-3
Mechanical	8-9
Electrical	8-10
Environment	8-10
Interface Specifications.....	8-11
Parallel interface	8-11
Serial interface	8-15
Initialization	8-17
Default settings.....	8-17



Printer Specifications

Printing

Printing method: 9-pin impact dot matrix

Pin configuration: Two 9-pin columns

Printing speed:

Quality	Characters per inch	Character/second/line
high-speed draft	10	1066
normal draft	10	800
	12	960
NLQ	10	160
	12	192

Printing direction: Bidirectional logic-seeking for text printing. Unidirectional for graphics (can also be switched to bidirectional using the proper software command).

Line spacing: 1/6-inch, 1/8-inch, or programmable in increments of 1/216th of an inch

Paper feed speed: Approx. 17 ms/line at 1/6-inch line spacing during continuous feeding
26 ms/line at 1/6-inch line spacing during intermittent feeding

Printable columns:

Character sizes	Maximum printed characters
10 cpi	136
10 cpi condensed	233
12 cpi	163
12 cpi condensed	272

Input buffer: 3Kbyte

Character *fonts*:

Font	Available sizes (characters per inch)
Epson high-speed draft	10
Epson draft	10, 12, proportional
Epson NLQ Roman	10, 12, proportional
Epson NLQ Sans Serif	10, 12, proportional

Characters: Standard ASCII character set with
96 characters (including italic characters)
13 international character sets (including italic characters)
Epson Extended Graphics character set

Paper

Paper type:

Continuous-feed paper:

- The sprocket holes must be perfectly circular or circular and notched.
- The holes must be cleanly cut.
- The perforation between pages should not extend all the way to the edges of the paper, as shown below.

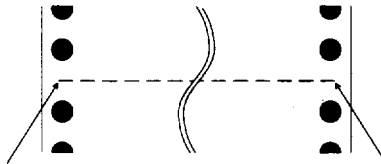

The edges of paper are not perforated.

- At the perforation between pages, the horizontal and vertical perforation cuts should not cross, as shown here:

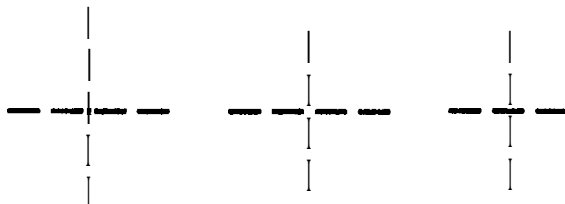

Multi-part forms:

- It is best to use pressure-sensitive multi-part forms.
- The form sheets should be securely joined together along the left and right edges with crimping (crash impressions), **spot-gluing**, or tape-stitching. For the best printing quality, use multi-part forms joined with **spot-gluing**. Never use **multi-part** forms joined with metal staples.
- Crimping should be punched from the original sheet side and go completely through all copy sheets. Also, crimping should be double-sided; using single-sided crimping may cause the printer to jam.

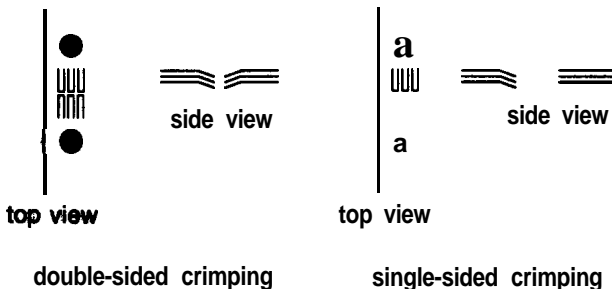

- For multi-part forms joined with spot-gluing, be sure the spots of glue are spaced the same way on the left and right edges of the paper.
- The binding area should be flat and have no creases.
- Overlapping multi-part forms should be joined together at the top of the pages and not along the sides of the pages.
- The sprocket holes of all the form sheets should be aligned properly.

Labels:

- Labels should be securely attached to the backing sheet.
- The backing sheet should be covered with the label material, both in the label area and in the spaces between labels. (The backing sheet should not be exposed.)
- The corners of the labels should be rounded.
- The label surface should be flat.

Paper width and length:

Paper	Width and length
Continuous paper (including multi-part forms)	Width: 101 to 406 mm (4.0 to 16.0")
Labels backing sheet	Width: 101 to 406 mm (4.0 to 16.0") Length: 88.9 mm (3.5") minimum
label	63.5 × 23.8 mm (2.50 × 0.94 ") minimum

Printer Specifications

Paper weight: Continuous paper: 14 to **22 lbs.**
(**52.6 to 82.7 g/m²**)
Multi-part forms: [**11 to 15 lbs.**] × N
(**[41.1 to 56.4 g/m²] × N**)
(**N ≤ 6**)

Paper thickness: Continuous paper (including multi-part forms):
Front - up to **0.46 mm (0.018")**
Rear - up to **0.30 mm (0.012")**
Labels:
Up to **0.19 mm (0.0075")** including backing sheet
Overlapping area on overlapping multi-part forms:
Up to **0.70 mm (0.028")**

Printable area: Continuous paper:

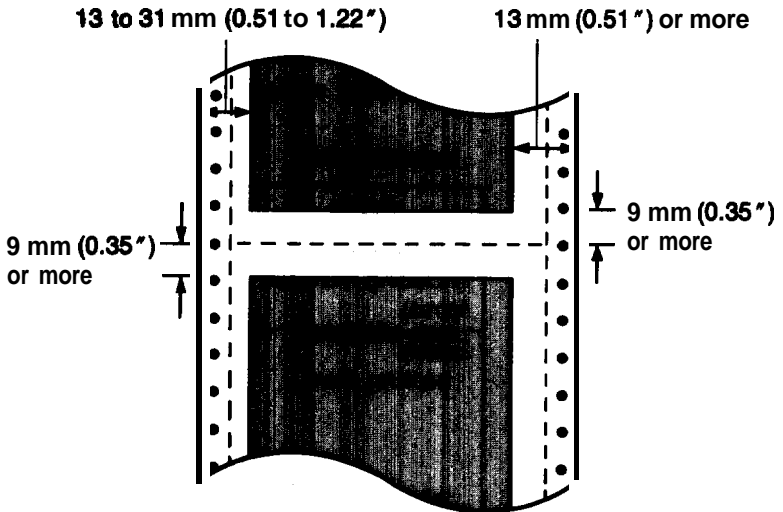

Labels:

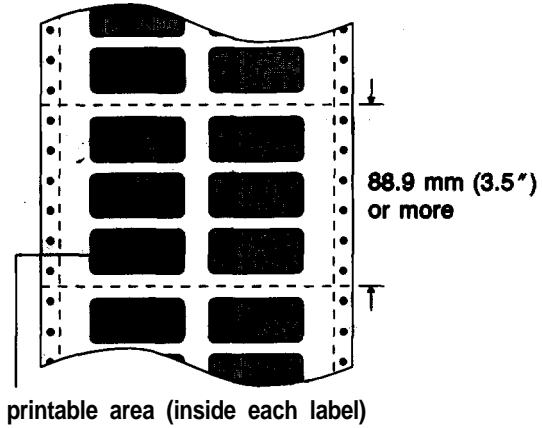

Overlapping multi-part forms:

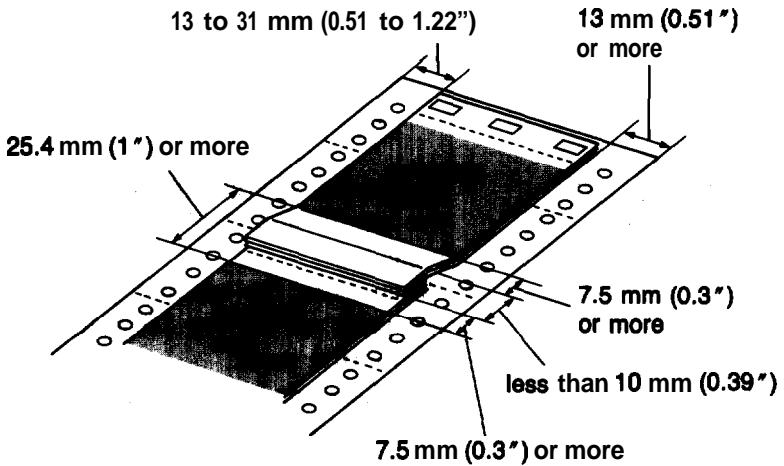

Multi-part forms with labels:

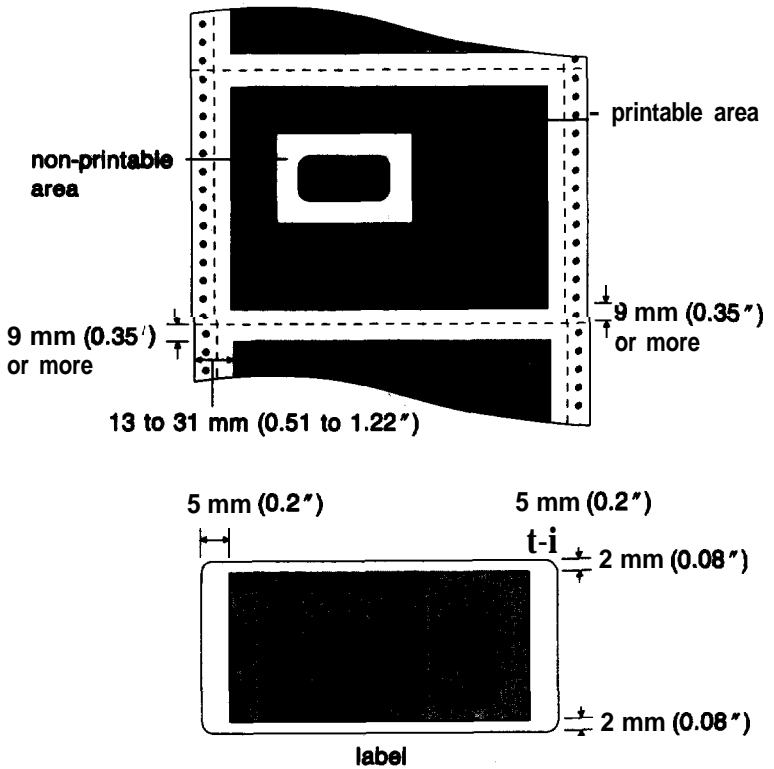

- Horizontal alignment may be irregular in the top **75 mm (3 inches)** of the first **page**.
- When using the optional pull tractor, do not print on the top 120 mm (4.8 inches) of the first page.
- Any holes or binding materials should be outside the printable area.

Number of copies: With continuous, multi-part forms only.
Front - one original plus up to five copies.
Total thickness must not exceed 0.46 mm
(0.018").
Rear - one original plus up to three copies.
Total thickness must not be exceed 0.30 mm
(0.012 ").

Mechanical

**Paper feed
methods:**

Push tractor
Pull tractor (optional)

Ribbon:

Cartridge ribbon, available in black only
(# 8766)
Life expectancy at 14 dots/character:
15 million characters

MCBF:

For all components excluding print head:
24,000,000 lines

MTBF:

6000 power-on hours (25% duty)

Print head life:

400 million characters at 14 dots/character

**Dimensions
and weight:**

Height: 369 mm (14.5")
Width: 700 mm (27.6")
Depth: 382 mm (15.0")
Weight: approx. 29 kg (63.9 lbs.)

Optional paper cutter:

Cutting position accuracy: **±3** mm (0.12")
Available cutting area:
3.0 to 25.4 mm (0.12 to 1.00") below the
perforation at the end of page

Printer Specifications

Electrical

Voltage:	103.5 to 132.0 VAC (120V model) 198.0 to 264.0 VAC (220-240V model)
Rated current:	7A (120V model) 5A (220-240V model)
Power consumption:	200 watts (during self test printing in draft mode)
Frequency:	49.5 to 60.5 Hz
Insulation resistance:	10 M ohms minimum (between AC power line and chassis)

Dielectric strength (between AC line and chassis):

120V model can withstand 1.00 KV rms applied for one minute or 1.20 KV rms applied for one second
220-240V model can withstand 1.25 KV rms applied for one minute or 1.50 KV rms applied for one second

Environment

Temperature:	Operation: +5° to +35°C (+41° to +95°F) Storage: -30° to +60°C (-22° to +140°F)
Humidity:	Operation: 10% to 80% RH without condensation Storage: 5% to 85% RH without condensation
Operation angle:	0°

Interface Specifications

This section provides specifications for the DFX8000's parallel and serial interfaces. For specifications on optional interfaces, see their manuals.

WARNING: The DFX-8000 has a parallel interface, a serial interface, and a slot for an optional interface. To avoid damaging the printer, do not connect cables to the parallel interface and the optional interface at the same time. Also do not plug cables into all three interfaces at the same time. However, you can connect cables to the serial interface and the parallel interface or the serial interface and the optional interface at the same time.

Parallel interface

The following table provides the parallel interface connector pin assignments and describes their interface signals.

Signal Pin	Return Pin	Signal	Director	Description
1	19	STROBE	IN	STROBE pulse to read data. Pulse width must be more than 0.5 microseconds at the receiving terminal.
2	20	DATA 1	IN	These signals represent information of the 1st to 8th bits of parallel data, respectively. Each signal is at HIGH level when data is logical 1 and LOW when it is logical 0 .
3	21	DATA 2	IN	
4	22	DATA 3	IN	
5	23	DATA 4	IN	
6	24	DATA 5	IN	
7	25	DATA 6	IN	
8	26	DATA 7	IN	
9	27	DATA 6	IN	

Interface Specifications

Signal Pin	Return Pin	Signal	Direction	Description
10	28	<u>ACKNLG</u>	OUT	About a 12-microsecond pulse . LOW indicates that data has been received and that the printer is ready to accept more data.
11	29	BUSY	OUT	A HIGH signal indicates that the printer cannot receive data. The signal goes HIGH in the following cases: 1) during data entry (ea. char. time) 2) when off line 3) during a printer error state 4) during printing
12	30	PE	OUT	A HIGH signal indicates that the printer is out of paper.
13	—	—	—	Pulled up to +5 volts through 3.3K ohm resistance.
14	—	<u>AUTO FEED XT</u>	IN	When this signal is LOW, the paper is automatically fed one line after printing. (The signal level can be fixed to this by turning on DIP switch 2-4.)
15	—	NC	—	Not used.
16	—	0V	—	Logic ground level.
17	—	CHASS GND	S —	Printer's chassis ground, which is isolated from the logic ground.
18	—	NC	—	Not used.
19-30	—	GND	—	Twisted-pair return signal ground level.
31	—	<u>INIT</u>	IN	When this level becomes LOW, the printer controller is reset to its power-up state and the print buffer is cleared. This level is usually HIGH ; its pulse width must be more man 50 microseconds at the receiving terminal.

Signal Pin	Return Pin	Signal	Direction	Description
32	—	ERROR	OUT	This level becomes LOW when the printer is: 1) out of paper 2) off time 3) in a printer error state
33	—	GND	—	Same as for pins 19 - 30.
34	—	NC	—	Not used.
35	—	—	—	Pulled up to +5V through 3.3K ohm resistance.
36	—	SLCT IN	I N	The DC1/DC3 code is valid only when this signal is HIGH. (Internal fixing is possible with jumper J1.)

- All interface conditions are based on **TTL** level. Both the rise and the fall times of each signal must be less than **0.2** microseconds.
- Data transfer is carried out by observing the **ACKNLG** or **BUSY** signal. Data transfer to this printer occurs only after receipt of the **ACKNLG** signal or when the level of the **BUSY** signal is **LOW**.
- The column heading “Direction” refers to the direction of signal flow as viewed from the printer.
- “Return” denotes the twisted-pair return to be connected at signal ground level. For interface wiring, be sure to use a twisted-pair cable for each signal and to complete the connection on the return side. These cables should be shielded and connected to the chassis of the host computer and the printer.

Interface Specifications

Interface timing

The figure below shows the timing for the parallel interface.

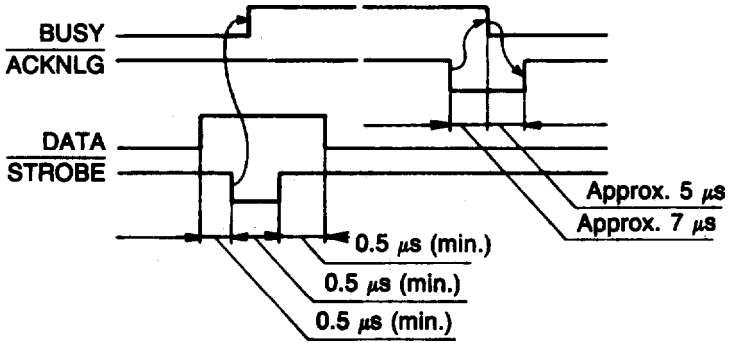

Printing enabled/disabled signals and control conditions

The **table below** shows the relationship between printing being enabled or **disabled**, the **on** line/off line status, and **the** receipt of the data on/off control characters, **DC1** and **DC3**.

On-line (indicator on)	SLCT IN	DC1/DC3 (data on/off control)	ERROR	BUSY	ACKNLG	Printing (disabled/enabled)
On-line	Low (J1/interface)	DC1/DC3 (no effect)	High	High/Low	Pulsed ea. char.	Enabled (normal cond.)
On-line	High	DC1 recv'd	High	High/Low	Pulsed ea. char.	Enabled
On-line	High	DC3 recv'd	High	High/Low	Pulsed ea. char.	Disabled
Off-line	High/Low (no effect)	DC1/DC3 (no effect)	Low	High	Not generated	Disabled

* While printing is disabled, the printer receives and acknowledges character data so that it can look for another **DC1** character, which allows it to resume printing.

Serial interface

The DFX-8000's built-in serial interface is an RS-232C asynchronous interface. It has the following characteristics:

- Data format:** 1 start bit
- Data word length :** 7 or 8 bit
Odd, even, or no parity
1 stop bit
- Baud rate:** 300, 1200, 9600, or 19200 bits per second
- Signal level:** Mark (1) -3 to -27V
Space (0) +3 to +27V
- Handshaking:** Handshaking by DTR signal or X-on/X-off

Available bytes in the input buffer	Printer status	Signal
Decreases to 512 bytes	Cannot receive input data	Sends X-OFF code or sets DTR to 1 (Mark)
Increases to 784 bytes	Can receive input data	Sends X-ON code or sets DTR flag to 0 (Space)

Error handling: When a parity error is detected, the printer prints an asterisk (*). All other errors are ignored.

Connector: 25-pin EIA connector

Interface Specifications

Pin assignments for the serial interface:

Pin Number	Signal	Direction	Description
1	CG	—	Printer chassis ground.
2	TXD	OUT	Transmits' data for X-on/X-off.
3	RXD	IN	Receives data.
4-6	NC	—	Not used.
7	SG	—	Signal (logic) ground.
8-10	NC	—	Not used.
11	DTR	OUT	Indicates whether the printer is ready to receive input data. MARK level indicates printer is not ready to receive data.
12-19	NC	—	Not used.
20	DTR	OUT	Same as pin 11.
21-25	NC	—	Not used.

- The column heading “Direction” refers to the direction of signal flow from the printer,

Initialization

The table below describes the three ways that the printer can be initialized (returned to a fixed set of conditions).

Hardware initialization	<ul style="list-style-type: none">• The printer is turned on.• The printer receives an INIT signal at the parallel interface (pin 31 goes LOW).
Software initialization	<ul style="list-style-type: none">• The software sends the ESC @ (initialize the printer) command.

Default settings

The following table shows the default conditions that become valid when the printer is initialized.

Item	Default condition
Top of form position	Last setting by TOP OF FORM button
Page length	The current DIP switch setting
Left and right margins	Cancelled
Line spacing	1/6-inch line spacing
Vertical tab position	Cleared
Horizontal tab position	Every eight characters
VFU channel	Channel 0
Condensed mode	The current DIP switch setting
Justification	Left justification
Special printing effects	The current DIP switch settings where applicable. Other effects are cancelled .
Graphic mode assignment	ESC K = ESC * 0, ESC L = ESC * 1, ESC Y = ESC * 2, ESC Z = ESC * 3
User-defined character set	Epson ESC/P mode: not cleared IBM emulation mode: cleared

Initialization

Note: The data buffer is cleared **only when** the printer is initialized by turning on the power or by an **INIT** signal.

Chapter 9

Command Summary

Using the Command Summary	9-2
Control key chart	9-4
Commands in Numerical Order	9-5
Epson ESC/P Commands Arranged by Topic	9-9
Printer operation	9-9
Data control	9-12
Vertical motion	9-13
Horizontal motion	9-19
Overall printing style	9-23
Print size and character width	9-25
Print enhancement	9-29
Word processing	9-33
Character tables	9-34
User-defined characters	9-36
Graphics	9-38
IBM Emulation Mode Commands Arranged by Topic	9-41
Commands that duplicate Epson ESC/P commands	9-41
Commands that differ from Epson ESC/P commands	9-42

Using the Command Summary

This chapter lists and describes all the commands available on the DFX-8000. This chapter includes the commands available in both Epson ESC/P mode and IBM emulation mode.

Note: Epson ESC/P mode is selected when DIP switch 1-4 is turned off. To select IBM emulation mode, turn on DIP switch **1-4**.

The first part of this chapter lists, all commands in numerical order and gives the number of the page where each is fully described. If you know which command you are looking for, consult the numerical list.

Note: The Quick Reference card at the end of this **manual also lists** the commands by topic with page numbers that **direct** you to full explanations of the commands, The numerical list and the Quick Reference card indicate which commands work differently in Epson **ESC/P** mode and IBM emulation mode.

The second part of this chapter describes the commands available in Epson **ESC/P** mode and the third part of this chapter describes the commands available in IBM emulation mode. These sections list and describe each command separately. The commands are divided into the following subjects:

Printer operation	Print enhancement
Data control	Word processing
Vertical motion	Character tables
Horizontal motion	User-defined characters
Overall printing style	Graphics
Print size and character width	

Each command description has a format section and a comment section. The format section gives the ASCII, decimal, and hexadecimal values for the command. These three formats are equivalent, and it should be easy to pick the one most suited to your purpose. The comment section describes the effect of the command and gives any additional information necessary for using it.

Note: Some application programs can use control key sequences. See the Control key chart on page **9-4** for information on using control keys.

The simplest type of command consists of a single character to be sent to the printer. For instance, to print in condensed mode the code format is:

ASCII code:	SI
Decimal :	15
Hexadecimal:	0F

This code can be sent from a program by sending the code **15** directly.

More complex commands consist of two or more character codes. For example, to print in double-wide mode the code format is the following:

ASCII code:	ESC	W	<i>n</i>
Decimal:	27	87	<i>n</i>
Hexadecimal:	1B	57	<i>n</i>

In this case *n* can be either 1 or 0, to begin or end double-wide printing. You can use either of the following commands to turn on double-wide printing from BASIC:

```
LPRINT CHR$(27):CHR$(87):CHR$(1)
LPRINT CHR$(27):"W":CHR$(1)
```

Using the Command Summary

For the following commands that use only 0 or 1 for the variable, either the decimal or hexadecimal values 1 and 0 or the ASCII characters 1 and 0 can be used:

ESC U, ESC x, ESC p, ESC W, ESC S, ESC -, ESC w, and ESC %

For example, in BASIC you can select draft mode with either of these statements:

```
LPRINT CHR$(27);"x";CHR$(0)
LPRINT CHR$(27);"x";"0"
```

Control key chart

Some application programs can use control key codes for decimal values 0 through 27. The table below gives you the proper values. The Control Key column indicates that you press the control key at the same time you press the key for the letter or symbol in that column. For example, you press the control key and A at the same time to send the value 1.

Note: Many programs use the control keys for other purposes. Also, some programs do not use all these keys.

Dec	Hex	control key
0	00	@
1	01	A
2	02	B
3	03	C
4	04	D
5	05	E
6	06	F
7	07	G
8	08	H
9	09	I
10	0A	J
11	0B	K
12	0C	L
13	0D	M

Dec	Hex	control key
14	0E	N
15	0F	O
16	10	P
17	11	Q
18	12	R
19	13	S
20	14	T
21	15	U
22	16	V
23	17	W
24	18	X
25	19	Y
26	1A	Z
27	1B	[

Commands in Numerical Order

This section lists all the **DFX** commands, with their decimal and hexadecimal values. The numbers in the columns on the right are the page numbers in this chapter where you can find a complete description of the command. If the Epson **ESC/P** and IBM emulation mode **page** numbers are the same, the command is the same in both modes and is described only in the Epson **ESC/P** mode section.

ASCII	Dec	Hex	Description	Epson ESC/Pmode	IBM emulationmode
BEL	7	07	Beeper	9-12	9-12
BS	8	08	Backspace	9-20	9-20
HT	9	09	Tab Horizontally	9-22	9-22
LF	10	0A	Line Feed	9-15	9-15
VT	11	0B	Tab Vertically	9-17	9-17
FF	12	0C	Form Feed	9-14	9-14
CR	13	0D	Carriage Return	9-12	9-12
s o	14	0E	Select Double-wide Mode (one line)	9-27	9-27
SI	15	0F	Select Condensed Mode	9-26	9-26
DC1	17	11	Select Printer	9-9	9-9
DC2	18	12	Cancel Condensed Mode	9-26	
DC2	18	12	Select 10 cpi		9-47
DC3	19	13	Deselect Printer	9-10	9-10
DC4	20	14	Cancel Double-wide Mode (one line)	9-27	9-27
CAN	24	18	Cancel Line	9-13	9-13
DEL	127	7F	Delete Character	9-13	
ESC SO	14	0E	Select Double-wide Mode (one line)	9-27	9-27
ESC SI	15	0F	Select Condensed Mode	9-26	9-26
ESC EM	25	19	Select Paper Path	9-12	
ESC SP	32	20	Set Intercharacter Space	9-33	
ESC I	33	21	Master Select	9-24	
ESC #	35	23	Cancel MSB Control	9-11	
ESC \$	36	24	Set Absolute Print Position	9-21	

Commands in Numerical Order

ASCII	Dec	Hex	Description	Epson ESC/P	IBM mode	IBM emulation mode
ESC %	37	25	Select User-defined Set	9-37		
ESC &	38	26	Define User-defined Characters	9-36		
ESC *	42	2A	Select Graphics Mode.....	9-39		
ESC -	45	2D	Turn Underlining Mode On/Off	9-32		9-32
ESC /	47	2F	Select Vertical Tab Channel	9-19		
ESC 0	48	30	Select 1/g-inch Line Spacing	9-15		9-15
ESC 1	49	31	Select 7/72-inch Line Spacing	9-16		9-16
ESC 2	50	32	Select 1/6-inch Line Spacing	9-16		
ESC 2	50	32	Select Programmable Line Spacing			9-42
ESC 3	51	33	Set n/216-inch Line Spacing	9-16		9-16
ESC 4	52	34	Select Italic Mode	9-31		
ESC 4	52	34	Set Top of Form			9-43
ESC 5	53	35	Cancel Italic Mode.....	9-32		
ESC 5	53	35	Turn Automatic Line Feed On/Off			9-43
ESC 6	54	36	Enable Printable Characters	9-35		
ESC 6	54	36	Select International Character Set			9-49
ESC 7	55	37	Enable Upper Control Codes	9-35		
ESC 7	55	37	Select Standard Character Set			9-49
ESC :	58	3A	Copy ROM to RAM	9-36		
ESC :	58	3A	Select 12 cpi			9-47
ESC <	60	3C	Select Unidirectional Mode (one line)	9-10		
ESC =	61	3D	Set MSB to 0	9-11		
ESC =	61	3D	Define User-defined Characters			9-50

Commands *in Numerical Order*

ASCII	Dec	Hex	Description	Epson ESC/P	IBM mode emulation mode
ESC >	62	3E	Set MSB to 1	9-11	
ESC ?	63	3F	Reassign Graphics Mode	9-40	
ESC @	64	40	Initialize Printer	9-9	
ESC A	65	41	Set n/72-inch Line Spacing	9-17	
ESC A	65	41	Set n/72-inch Line Spacing		9-43
ESC B	66	42	Set Vertical Tabs	9-18	9-44
ESC C	67	43	set Page Length in Lines...	9-13	9-13
ESC C 0	67	43	Set Page Length in Inches ...	9-14	9-14
ESC D	68	44	Set Horizontal Tabs	9-22	9-45
ESC E	69	45	Select Emphasized Mode	9-29	9-29
ESC F	70	46	Cancel Emphasized Mode ...	9-29	9-29
ESC G	71	47	Select Double-Strike Mode ..	9-30	9-30
ESC H	72	48	Cancel Double&trike Mode	9-30	9-30
ESC I	73	49	Printable Code Area Expansion	9-37	
ESC I	73	49	Select Font		9-46
ESC J	74	4A	Perform n/216-inch Line Feed	9-17	9-44
ESC K	75	4B	Select Single-density Graphics Mode.....	9-38	9-38
ESC L	76	4C	Select Double-density Graphics Mode.....	9-38	9-38
ESC M	77	4D	Select 12 cpi	9-25	
ESC N	78	4E	Set Ship Over Perforation .	9-14	9-14
ESC 0	79	4F	Cancel Ship Over Perforation	9-15	9-15
ESC P	80	50	Select 10 cpi	9-25	
ESC P	80	50	Turn Proportional Mode On/Off		9-47
ESC Q	81	51	Set Right Margin	9-20	
ESC Q22	81	51	Deselect Printer		9-42
ESC R	82	52	Select an International Character Set	9-34	
ESC R	82	52	Restore Default Tab Settings		9-45

Commands in Numerical Order

ASCII	Dec	Hex	Description	Epson ESC/P mode	IBM emulation mode
ESC SO	83	53	Select Superscript Mode	9-30	9-30
ESC S 1	83	53	Select Subscript Mode.....	9-31	9-31
ESC T	84	54	Cancel Superscript/ Subscript Mode	9-31	9-31
ESC U	85	55	Turn Unidirectional Mode On/Off	9-10	9-10
ESC X	88	58	Set Left and Right Margins		9-46
ESC W	87	57	Turn Double-wide Mode On/Off	9-28	9-28
ESC Y	89	59	Select High-speed Double - density Graphics Mode.....	9-38	9-38
ESC Z	90	5A	Select Quadruple-density Graphics Mode.....	9-39	9-39
ESC [@	91	5B	Set Double-high/Double - wide Printing		9-48
ESC \	92	5C	Set Relative Print Position . .	9-21	
ESC \	92	5C	Print Characters from Symbol Set		9-49
ESC ^	94	5E	Select 9-pin Graphics Mode	9-40	
ESC ^	94	5E	Print One Character from Symbol Set		9-50
ESC _	95	5F	Turn Overscoring Mode On/Off		9-48
ESC a	97	61	Select Justification	9-33	
ESC b	98	62	Set Vertical Tabs in Channels	9-18	
ESC k	107	6B	Select Typestyle Family	9-23	
ESC l	108	6C	Set Left Margin	9-19	
ESC p	112	70	Turn Proportional Mode On/Off	9-25	
ESC t	116	74	Select Character Table	9-34	
ESC w	119	77	Turn Double-high Mode On/Off	9-28	
ESC x	120	78	Select Near Letter Quality or Draft	9-23	

Epson ESC/P Commands Arranged by Topic

This section lists and describes all the commands available in Epson ESC/P mode.

Printer operation

ESC @

Initialize Printer

Format:

ASCII code:	ESC	@
Decimal:	27	64
Hexadecimal:	1B	40

Comments:

Resets the printer mode and clears the buffer of printable data on the print line preceding the command.

DC1

Select Printer

Format:

ASCII code:	DC1
Decimal:	17
Hexadecimal:	11

Comments:

Returns the printer to the selected state if it has been deselected by the printer deselect code (**DC3**). Does not select the printer if it has been switched off line by pressing the **ON LINE** button.

DC3

Deselect Printer

Format:

ASCII code: DC3
Decimal: 19
Hexadecimal: 13

Comments:

Puts the printer into ~~the~~ deselected state until the select ^{*}printer code (**DC1**) is received. The printer cannot be reselected with the **ON LINE** button.

ESC <

Select Unidirectional Mode (one line)

Format:

ASCII code: ESC <
Decimal: 27 60
Hexadecimal: 1B 3C

Comments:

Printing is normally bidirectional. This command selects unidirectional printing for one line only. (It is **cancelled** by a carriage return.) The print head moves to the extreme left (home) position, and printing takes place from left to right.

ESC U

Turn Unidirectional Mode On/Off

Format:

ASCII code: ESC U n
Decimal : 27 85 n
Hexadecimal: 1B 55 n

Comments:

The following values can be used for *n*:

1: Mode is **turned** on.

0: Mode is turned off.

Text printing is normally bidirectional. This command selects unidirectional printing for more accurate positioning.

Note: **MSB** is the Most Significant Bit. **MSB** control (**ESC =**, **ESC >**, and **ESC #**) is not valid for graphics or user-defined character.

ESC = (equal) Set **MSB** to 0

Format:

ASCII code:	ESC	=
Decimal:	27	61
Hexadecimal:	1B	3D

Comments:

Sets the **MSB** of all incoming data to **0**. Some computers always send data with the **MSB** set to **1**, which means that italics or character graphics are always printed. **ESC =** can overcome this problem.

ESC > Set **MSB** to 1

Format:

ASCII code:	ESC	>
Decimal:	27	62
Hexadecimal:	1B	3E

Comments:

Sets the **MSB** bit of all incoming data as **1**.

ESC # Cancel **MSB** Control

Format:

ASCII code:	ESC	#
Decimal:	27	35
Hexadecimal:	1B	23

Comments:

Cancels the **MSB** control set by **ESC =** or **ESC >**.

ESC EM

Select Paper Path

Format:

ASCII code:	ESC	EM	<i>n</i>
Decimal:	27	25	<i>n</i>
Hexadecimal:	1B	19	<i>n</i>

Comments:

The following values can be used for *n*:

F : Selects the front tractor.

B : Selects the rear tractor.

Use this command only when the paper cutter is installed.

BEL

Beeper

Format:

ASCII code:	BEL
Decimal:	7
Hexadecimal:	07

Comments:

Sounds the printer's beeper.

Data control

CR

Carriage **Return**

Format:

ASCII code:	CR
Decimal:	13
Hexadecimal:	0D

Comments:

Prints the data in the buffer and returns the print position to the left margin. A line feed may be added if DIP switch **2-4** is on or the AUTO FEED XT line on the parallel interface is held LOW.

CAN

Cancel Line

Format:

ASCII code: CAN

Decimal: **24**

Hexadecimal : **18**

Comments:

Removes all text on the print line but does not affect control codes.

DEL

Delete Character

Format :

ASCII code: DEL

Decimal: **127**

Hexadecimal: **7F**

Comments:

Removes the last text character on the print line but does not affect control codes.

Vertical motion

ESC C

Set Page Length in Lines

Format:

ASCII code: **ESC C n**

Decimal : **27 67 n**

Hexadecimal: **1B 43 n**

Comments:

Sets the page length to **n** lines in the current line spacing. The value of **n** must be from **1** to **127**. The top of form position is set to the current line. Overrides the DIP switch page length setting.

ESC C 0

Set Page Length in Inches

Format:

ASCII code:	ESC	C	0	<i>n</i>
Decimal:	27	67	0	<i>n</i>
Hexadecimal:	1B	43	00	<i>n</i>

Comments:

Sets the page length to ***n*** inches. The value of ***n*** must be from **1** to **22**. The top of form position is set to the current line. Overrides the DIP switch page length setting.

FF

Form Feed

Format:

ASCII code:	FF
Decimal:	12
Hexadecimal:	0C

Comments:

Prints the data in the print buffer and advances the paper to the top of the next form according to the current page length.

ESC N

Set Skip Over Perforation

Format:

ASCII code:	ESC	N	<i>n</i>
Decimal:	27	78	<i>n</i>
Hexadecimal:	1B	4E	<i>n</i>

Comments:

The variable ***n*** is the number of lines skipped between the last line printed on one page and the first line of the next page. For example, with the standard settings for line spacing (**1/6-inch**), and page length (**66** lines), **ESC N 6** cause the **DFX-8000** to print **60** lines and **then** skip **6**. DIP switch **3-3 performs** the same function. This setting is **cancelled** by **ESC 0** and also by **ESC C** or **ESC C 0**. The value of ***n*** must be from **1** to **127**. Overrides the 1-inch skip over perforation setting of DIP switch **3-3**.

ESC O Cancel Skip Over Perforation

Format:

ASCII code:	ESC	0
Decimal:	27	79
Hexadecimal:	1B	4F

Comments:

Cancels the skip over perforation set by **ESC N**. Also overrides the 1-inch skip over perforation setting of DIP switch **3-3**.

LF Line Feed

Format:

ASCII code:	LF
Decimal:	10
Hexadecimal:	0A

Comments:

When this command is received, the data in the print buffer is printed and the paper **advances** one line in the current line spacing.

ESC 0 Select 1/g-inch Line Spacing

Format:

ASCII code:	ESC	0
Decimal:	27	48
Hexadecimal:	1B	30

Comments:

Set the line spacing to **1/8** of an inch for subsequent line feed commands. **The 0** is the character zero **and** not ASCII code **0**.

ESC 1 Select **7/72-inch** Line Spacing

Format:

ASCII code:	ESC	1
Decimal:	27	49
Hexadecimal:	1B	31

Comments:

Sets the line spacing to **7/72** of an inch for subsequent line feed commands. The **1** is the character one and not lowercase **L** or ASCII code **1**.

ESC 2 Select **1/6-inch** Line Spacing

Format:

ASCII code:	ESC	2
Decimal:	27	50
Hexadecimal:	1B	32

Comments:

Sets the line spacing to **1/6** of an inch for subsequent line feed commands. The **2** is the character two and not ASCII code **2**. This is the default at power on.

ESC 3 Select **n/216-inch** Line Spacing

Format:

ASCII code:	ESC	3	<i>n</i>
Decimal:	27	51	<i>n</i>
Hexadecimal:	1B	33	<i>n</i>

Comments:

Sets the line spacing to **n/216** of an inch for subsequent line feed commands. The **3** is the character three and not ASCII code **3**. The value of ***n*** must be from 0 to **255**.

ESC A Select *n*/**72-inch** Line Spacing

Format:

ASCII code:	ESC	A	<i>n</i>
Decimal:	27	65	<i>n</i>
Hexadecimal:	1B	41	<i>n</i>

Comments:

Sets the line spacing to *n*/**72** of an inch for subsequent line feed commands. The value of *n* must be from 0 to **85**.

ESC J Perform *n*/**216-inch** Line Feed

Format:

ASCII code:	ESC	J	<i>n</i>
Decimal:	27	74	<i>n</i>
Hexadecimal:	1B	4A	<i>n</i>

Comments:

Advances the paper *n*/**216** of an inch. The value of *n* must be from 0 to **255**. This command produces an immediate line feed but does not affect subsequent line spacing and does not produce a carriage **return**.

VT Tab Vertically

Format:

ASCII code:	VT
Decimal :	11
Hexadecimal:	0B

Comments:

Advances the paper to the next tab setting in the channel selected by **ESC /**. If no channel has been selected, channel 0 is used. If no vertical tabs have been selected, the paper advances one line.

ESC B

Set Vertical Tabs

Format:

ASCII code:	ESC	B	<i>n1</i>	<i>n2</i>	0
Decimal:	27	66	<i>n1</i>	<i>n2</i>	0
Hexadecimal:	1B	42	<i>n1</i>	<i>n2</i>	00

Comments:

Sets **up** to **16** vertical tabs in the current line spacing. Tab settings are not affected **by** subsequent changes in line spacing. The tab settings are entered as *n1*, *n2*, etc., **all** from **1** to **255**, in ascending order. The **0** character indicates the end of the command. All settings are stored in channel **0** (see **ESC b**). **ESC B 0** clears the tab settings.

ESC b

Set Vertical Tabs in Channels

Format:

ASCII code:	ESC	b	<i>c</i>	<i>n1</i>	<i>n2</i>	0
Decimal:	27	98	<i>c</i>	<i>n1</i>	<i>n2</i>	0
Hexadecimal:	1B	62	<i>c</i>	<i>n1</i>	<i>n2</i>	00

Comments:

Functions the same as **ESC B**, except that the variable *c* selects a channel for the vertical tabs, which must be between **0** and **7**. Therefore, up to eight sets of vertical tabs can be set. The channels are selected by **ESC /**. To clear the tabs in channel *c*, use **ESC b c 0**.

ESC /

Select Vertical Tab Channel

Format :

ASCII code:	ESC	/	c
Decimal:	27	47	c
Hexadecimal:	1B	2F	c

Comments:

This command is used to select the vertical tab. channel. The value of **c** must be **from 0 to 7**. All subsequent vertical tab **commands** use the channel selected by this command. If no channel **has** been **selected**, channel 0 is used.

Horizontal motion

ESC 1

Set Left Margin

Format:

ASCII code:	ESC	1	n
Decimal:	27	108	n
Hexadecimal:	1B	6C	n

Comments:

Sets the left margin to **n** columns in the current character size. Settings made in proportional mode are treated as **10 cpi**. This command clears **previous tab settings** and all **previous** characters in the print line. Use lowercase 1 (for **left**), not the numeral one. The 'minimum **space between the margins** is the **width** of one double-wide **10 cpi** character.

ESC Q

Set Right Margin

Format:

ASCII code:	ESC	Q	<i>n</i>
Decimal:	27	81	<i>n</i>
Hexadecimal:	1B	51	<i>n</i>

Comments:

Sets the right margin to ***n*** columns in the current character size. Settings made in proportional mode are treated as **10 cpi**. This command clears previous tab settings and all previous characters in the print line. The minimum space between the margins is the width of one double-wide **10 cpi** character.

BS

Backspace

Format:

ASCII code:	BS
Decimal:	8
Hexadecimal:	08

Comments:

Prints out data in the print buffer, then moves the print position one space to the left. Backspacing can be performed up to, but not beyond, the left margin setting. Do not use the **BS** code if **ESC a 2** or **a 3** has been **sent**. If this code is received immediately after graphics printing, the print position of subsequent data is moved back to the point at which graphics printing started.

ESC \$

Set Absolute Print Position

Format:

ASCII code:	ESC	\$	<i>n1</i>	<i>n2</i>
Decimal:	27	36	<i>n1</i>	<i>n2</i>
Hexadecimal:	1B	24	<i>n1</i>	<i>n2</i>

Comments:

This sequence specifies the distance from the currently set left margin that **subsequent characters are to be printed**, using this formula: total number of dots = $n1 + (n2 \times 256)$. Each unit equals **1/60th** of an inch. The sequence is ignored and the previous setting remains effective if the position specified is beyond the right margin.

**ESC **

Set Relative Position

Format:

ASCII code:	ESC	\	<i>n1</i>	<i>n2</i>
Decimal:	27	92	<i>n1</i>	<i>n2</i>
Hexadecimal:	1B	5C	<i>n1</i>	<i>n2</i>

Comments:

Determines the position (**relative** to the current position) at which **printing of following data will start. To find *n1* and *n2*, first calculate the displacement required in 1/120ths of an inch. If the displacement is to the left, subtract it from 65536. Send the resulting number using this formula: total number. of dots = $n1 + (n2 \times 256)$.** The command is ignored if it would move the print position outside the current margins.

HT

Tab Horizontally

Format:

ASCII code: **HT**
Decimal: 9
Hexadecimal: **09**

Comments:

Advances the print position to the next horizontal tab setting. The default settings are at intervals of eight characters in the default, character size, and tab positions are not affected by subsequent changes in character size.

ESC D

Set Horizontal Tabs

Format:

ASCII code: **ESC D n1 n2 0**
Decimal: **27 68 n1 n2 0**
Hexadecimal: **1B 44 n1 n2 00**

Comments:

This command allows setting of up to **32** horizontal tabs, which are entered as **n1, n2, n3**, etc. (from **1** to **255**) with the **0** character or any value less than the previous **one terminating** the command. **ESC D 0** clears all tabs. The settings on power up or after an **ESC @** command are every **eight** characters. The tab settings do not **change if** the character size is changed. For proportional printing, the size of **10 cpi** characters determines the tab positions.

Overall **printing style**

ESC x

Select **NLQ** or Draft

Format:

ASCII code:	ESC	x	<i>n</i>
Decimal:	27	120	<i>n</i>
Hexadecimal:	1B	78	<i>n</i>

Comments:

The following values can be used for *n*:

0: Selects draft mode.

1: Selects near letter quality (**NLQ**) mode.

When **NLQ** is selected, the font used for printing is either Roman or **Sans** Serif, whichever is currently selected. Overrides the DIP switch setting.

ESC k

Select **Typestyle** Family

Format:

ASCII code:	ESC	k	<i>n</i>
Decimal:	27	107	<i>n</i>
Hexadecimal:	1B	6B	<i>n</i>

Comments:

This command affects only the near letter quality **typestyle**, not the draft **typestyle**.

You can use the following values for *n*:

0 = Roman

1 = **Sans** Serif

ESC !

Format:

ASCII code:	ESC	!	<i>n</i>
Decimal :	27	33	<i>n</i>
Hexadecimal:	1B	21	<i>n</i>

Comments:

Select any valid combination of the modes in the table below.

The variable ***n*** is determined by adding together the values of the desired modes from the table.

Mode	Dec	Hex
10 cpi	0	00
12 cpi	1	01
Proportional	2	02
Condensed	4	04
Emphasized	8	08
Double-strike	16	10
Double-wide	32	20
Italic	64	40
Underline	128	80

This command applies to both draft and **NLQ**. **10 cpi** cannot be combined with **12 cpi**, and proportional cannot be condensed. If both proportional and condensed are selected, proportional overrides condensed. If both emphasized and condensed are selected, emphasized is ignored. Double-strike is ignored in **NLQ**. For more information on selecting **typestyles** with Master Select, see Chapter 4.

Print **size** and character width

ESC P

Select **10 cpi**

Format:

ASCII code:	ESC	P
Decimal:	27	80
Hexadecimal:	1B	50

Comments:

Selects **10 cpi** (characters per inch) printing. This command is normally used to cancel **12 cpi**.

ESC M

Select **12 cpi**

Format:

ASCII code:	ESC	M
Decimal:	27	77
Hexadecimal:	1B	4D

Comments:

Select **12 cpi** (characters per inch) printing.

ESC p

Turn Proportional Mode On/Off

Format:

ASCII code:	ESC	p	n
Decimal:	27	112	n
Hexadecimal:	1B	70	n

Comments:

The following values can be used for **n**:

1: Mode is turned on.

0: Mode is **turned** off.

The width of proportional characters varies from character to character. Therefore, a narrow letter like **i** receives less space than a wide letter like **W**. The proportional widths are given in the character tables in the Appendix. This command overrides condensed.

SI **Select Condensed Mode**

Format:

ASCII code: **SI**
Decimal: **15**
Hexadecimal : **0F**

Comments:

Prints characters at about **60** percent of their normal width. For example, the condensed **10 cpi** mode has **17** characters per inch. Proportional mode cannot be Condensed, **and proportional** overrides condensed.

ESC SI **Select Condensed Mode**

Format:

ASCII code: **ESC** **SI**
Decimal : **27** **15**
Hexadecimal: **1B** **0F**

Comments:

Duplicates the **SI** command.

DC2 **Cancel Condensed Mode**

Format:

ASCII code: **DC2**
Decimal : **18**
Hexadecimal: **12**

Comments:

Cancels condensed printing set by **SI**, **ESC SI**, or DIP switch **1-1**.

SO Select Double-wide Mode (one line)

Format:

ASCII code: s o
Decimal: **14**
Hexadecimal: **0E**

Comments:

Double-wide mode doubles the wide of all characters. This mode is **cancelled** by a carriage return or **DC4**.

ESC SO Select Double-wide Mode (one line)

Format:

ASCII code: **ESC** SO
Decimal: **27** **14**
Hexadecimal: **1B** **0E**

Comments:

Duplicates the SO command.

DC4 Cancel ~~Double-wide~~ Mode (one line)

Format:

ASCII code: DC4
Decimal : **20**
Hexadecimal: **14**

Comments:

Cancels one-line double-wide printing selected by SO or **ESC SO**, but not double-wide printing selected by **ESC W** or **ESC I**.

ESC W **Turn Double-wide Mode On/Off**

Format:

ASCII code:	ESC	W	<i>n</i>
Decimal:	27	87	<i>n</i>
Hexadecimal:	1B	57	<i>n</i>

Comments:

You can use the following values for *n*:

1: Mode is turned on.

0: Mode is turned off.

Double-wide mode doubles the width of all characters.

ESC w **Turn Double-high Mode On/Off**

Format:

ASCII code:	ESC	w	<i>n</i>	
Decimal:	27	119		<i>n</i>
Hexadecimal:	1B	57	<i>n</i>	

Comments:

You can use the following values for *n*:

1: Mode is turned on.

0: Mode is turned off.

Double-high mode doubles the height of all characters. The superscript, subscript, and condensed modes do not work when double-high mode is selected.

Print enhancement

ESC E

Select Emphasized Mode

Format:

ASCII code:	ESC	E
Decimal:	27	69
Hexadecimal:	1B	45

comments:

Makes text bolder by printing each dot twice, with the second dot slightly to the right of the first.

ESC F

Cancel Emphasized Mode

Format:

ASCII code:	ESC	F
Decimal:	27	70
Hexadecimal:	1B	46

Comments:

Cancels emphasized, the mode selected by **ESC E** or **ESC I**.

ESC G

Select Double-strike Mode

Format:

ASCII code:	ESC	G	
Decimal:	27	71	
Hexadecimal:	1B	47	

Comments:

Makes text bolder by printing each line twice, with the second printing slightly below the first. Double-strike is not available in high-speed draft or **NLQ** mode.

ESC H

Cancel Double-strike Mode

Format:

ASCII code:	ESC	H	
Decimal:	27	72	
Hexadecimal:	1B	48	

Comments:

Turns off double-strike mode selected by **ESC G** or **ESC I**.

ESC S 0

Select Superscript Mode

Format:

ASCII code:	ESC	S	0
Decimal:	27	83	0
Hexadecimal:	1B	53	00

Comments:

Prints characters about two-thirds of the normal height in the upper part of the character space. Superscript is **cancelled** with **ESC T**. It cannot be combined with double-high mode.

ESC S 1

Select Subscript Mode

Format:

ASCII code:	ESC	S	1
Decimal:	27	83	1
Hexadecimal:	1B	53	01

Comments:

Prints characters about two-thirds of the normal height in the lower part of the character space. Subscript is **cancelled** with **ESC T**. It cannot be combined with double-high mode.

ESC T

Cancel Superscript/Subscript

Format:

ASCII code:	ESC	T
Decimal:	27	84
Hexadecimal:	1B	54

Comments:

Cancels either superscript or subscript.

ESC 4

Select Italic Mode

Format:

ASCII code:	ESC	4
Decimal:	27	52
Hexadecimal:	1B	34

Comments:

Causes italic characters to be printed. This command is valid even if the Epson Extended Graphics character set has been selected by **ESC t** or DIP switch 1-3, but character graphics (ASCII codes **176** to **223** and **240** to **254**) cannot be italicized.

ESC 5

Cancel Italic Mode

Format:

ASCII code:	ESC	5
Decimal :	27	53
Hexadecimal:	1B	35

Comments:

Cancels the mode selected by **ESC 4** or **ESC I**.

ESC -

Turn Underlining Mode On/Off

Format:

ASCII code:	ESC	-	n
Decimal:	27	45	n
Hexadecimal:	1B	2D	n

Comments:

The following values can be used for **n**:

1: Mode is **turned** on.

0: Mode is **turned** off.

This mode provides continuous **underlining**, including spaces.

Word processing

ESC a Select Justification

Format:

ASCII code:	ESC	a	n
Decimal:	27	97	n
Hexadecimal:	1B	61	n

Comments:

The following values can be used for **n**:

0: Selects left justification.

1: Selects centering.

2: Selects right justification.

3: **Selects** full justification.

The default setting is **n=0**. Full justification (n-3) is performed when the buffer becomes full or when a CR, VT, **LF**, or **FF** command is received. The commands DEL and **BS** are invalid in **n=3** mode. For **n=3** there must be **no carriage** returns within a **paragraph**.

ESC SP (space) Set **Intercharacter** Space

Format:

ASCII code:	ESC	SP	n
Decimal:	27	32	n
Hexadecimal:	1B	20	n

Comments:

Set the amount of space added to the right of each character in addition to the space already allowed in the design of the character. The number of units of space is equal to **n**, **which** should be from **0** to **127**. Each unit of space is **1/120th** of an inch.

Character tables

ESC t

Select Character Table

Format:

ASCII code:	ESC	t	n
Decimal:	27	116	n
Hexadecimal:	1B	74	n

Comments:

The following values can be used for **n**:

0: Selects italic character set.

1: Selects Epson Extended Graphics character set.

Selects the character table used by ASCII codes **128** through **255**.

Selecting Epson Extended Graphics **does not disable** italic printing. **Italic** printing **can** still be selected by **ESC 4**.

Duplicates and overrides the function of DIP switch 1-3. Note that the value of **n must equal 00 hex or 01 hex**. See the Appendix for the **character** tables.

ESC R

Select an **International** Character Set

Format:

ASCII code:	ESC	R	n
Decimal:	27	82	n
Hexadecimal:	1B	52	n

Comments:

The following values can be used for **n**:

0 - USA

5 = Sweden

9 = Norway

1 - France

6 = Italy

10 = Denmark II

2 = Germany

7 = Spain I

11 = Spain II

3 = UK

8 = Japan

12 = Latin America

4 = Denmark I

Overrides the DIP switch settings for **international** characters. See the section on **international** character sets in Chapter 3 for full information on **international** character sets.

ESC 6

Enable Printable Characters

Format:

ASCII code:	ESC	6
Decimal:	27	54
Hexadecimal:	1B	36

Comments:

Enables the printing of codes **128** through **159** (decimal) as characters, not control codes. This is the default when the Epson **Extended Graphics character** table is selected **by** DIP switch 1-3. See the Appendix **for** the characters that are **printed** with these codes.

ESC 7

Enable Upper Control Codes

Format:

ASCII code:	ESC	7
Decimal:	27	55
Hexadecimal:	1B	37

Comments:

This code causes codes **128** through **159** to be treated as control codes. When **the italic** character table is selected by DIP switch 1-3, this is the default.

User-defined characters

ESC & Define User-defined Characters

Format:

ASCII code:	ESC &	0	n1	n2	a1	d1	d2	dn
Decimal:	27 38	0	n1	n2	a1	d1	d2	dn
Hexadecimal:	1B 26	00	n1	n2	a1	d1	d2	dn

Comments:

This command defines characters in the currently selected mode.
This command does not work when DIP switch **2-1** is on.

ESC : Copy ROM into RAM

Format:

ASCII code:	ESC	:	0	n	0
Decimal:	27	58	0	n	0
Hexadecimal:	1B	3A	00	n	00

Comments:

This command copies the characters in the ROM into RAM so that specific characters can be redefined. This command does not work when DIP switch 2-1 is on. One of **the NLQ** fonts is copied depending on the value specified for **n**.

0: Roman

1: **Sans** Serif

ESC % Select **User-defined** Set

Format:

ASCII code:	ESC	%	<i>n</i>
Decimal:	27	37	<i>n</i>
Hexadecimal:	1B	25	<i>n</i>

Comments:

The following values can be used for ***n***:

0: Selects the normal set.

1: Selects the **user-defined** set.

ESC & is required to define the character set.

ESC I Printable Code Area Expansion

Format:

ASCII code:	ESC	I	<i>n</i>
Decimal:	27	73	<i>n</i>
Hexadecimal:	1B	49	<i>n</i>

Comments:

ASCII codes **0** to **31** and **128** to **159** are usually not printable.

These codes become printable when the **ESC I** command is received if ***n* = 1**. When these codes are printable, they can be used for **user-defined** characters. If ***n* = 0**, this command **returns** codes 0 to **31** and **128** to **159** to non-printable codes.

Graphics

See Chapter 4 for sample graphics programs. Also see the table under **ESC *** for graphics modes.

ESC K Select **Single-density Graphics** Mode

Format:

ASCII code:	ESC	K	<i>n1</i>	<i>n2</i>
Decimal:	27	75	<i>n1</i>	<i>n2</i>
Hexadecimal:	1B	4B	<i>n1</i>	<i>n2</i>

Comments:

Turns on eight-pin **single-density** graphics mode (**60** dots per **inch**). The total number of columns = $n1 + (n2 \times 256)$.

ESC L Select **Double-density** Graphics Mode

Format:

ASCII code:	ESC	L	<i>n1</i>	<i>n2</i>
Decimal:	27	76	<i>n1</i>	<i>n2</i>
Hexadecimal:	1B	4C	<i>n1</i>	<i>n2</i>

Comments:

Turns on eight-pin low-speed double-density graphics mode (**120** dots per inch). The total number of columns = $n1 + (n2 \times 256)$.

ESC Y Select High-speed **Double-density** Graphics Mode

Format:

ASCII code:	ESC	Y	<i>n1</i>	<i>n2</i>
Decimal:	27	89	<i>n1</i>	<i>n2</i>
Hexadecimal:	1B	59	<i>n1</i>	<i>n2</i>

Comments:

Turns on eight-pin high-speed double-density graphics mode (**120** dots per inch). The total number of columns = $n1 + (n2 \times 256)$.

ESC Z Select Quadruple-density Graphics Mode

Format:

ASCII code:	ESC	Z	<i>n1</i>	<i>n2</i>
Decimal:	27	90	<i>n1</i>	<i>n2</i>
Hexadecimal:	1B	5A	<i>n1</i>	<i>n2</i>

Comments:

Turns on eight-pin **quadruple-density** graphics mode (**240** dots per inch). **The** total number **of columns** = $n1 + (n2 \times 256)$.

ESC * Select Graphics Mode

Format:

ASCII code:	ESC	*	<i>m</i>	<i>n1</i>	<i>n2</i>
Decimal:	27	42	<i>m</i>	<i>n1</i>	<i>n2</i>
Hexadecimal:	1B	2A	<i>m</i>	<i>n1</i>	<i>n2</i>

Comments:

Turns on graphics mode *m*. See the table below for information on **the available modes**. **The total number of columns** = $n1 + (n2 \times 256)$.

Option	Alternate Code	<i>m</i>	Horiz. density (dots/inch)
Single-density	ESC K	0	60
Double-density	ESC L	1	120
High-speed double-density'	ESC Y	2	120
Quadruple-density*	ESC Z	3	240
CRT I	none	4	80
Plotter (1:1)	none	5	72
CRT II	none	6	90
Double-density plotter	none	17	144

- Adjacent dots cannot be printed in this mode.

ESC ? Reassign Graphics Mode

Format:

ASCII code:	ESC	?	s	n
Decimal:	27	63	s	n
Hexadecimal:	1B	3F	s	n

Comments:

Changes from one graphics mode to another. The variable **s** is a character (**K**, **L**, **Y**, or **Z**), which is reassigned to a mode **n** (0-7).

ESC ^ Select **9-Pin** Graphics Mode

Format:

ASCII code:	ESC	^	m	n1	n2
Decimal :	27	94	m	n1	n2
Hexadecimal:	1B	5E	m	n1	n2

Comments:

Turns on **9-pin** graphics mode. The variable **m** defines density of print: 0 for single (**60 dpi**) and 1 for double (**120 dpi**). The total number of columns = **n1 + (n2 × 256)**. This mode requires two data items for each column of print.

IBM Emulation Mode Commands Arranged by Topic

This section lists and describes the commands available in IBM emulation mode. Commands that are **the same** in IBM emulation and Epson **ESC/P mode are listed here and described in the Epson ESC/P** command section. Commands that have **different** functions in IBM emulation mode are fully described here.

Commands that duplicate Epson ESC/P commands

This section lists commands that are **the same** in IBM **emulation** and Epson **ESC/P** mode. See the section on Epson **ESC/P** commands for descriptions **of** the commands listed below.

Printer operation:

BEL, DC1, DC3, ESC U

Data control:

CR, CAN

Vertical motion:

LF, VT, FF, ESC 0, ESC 1, ESC 3, ESC C, ESC CO, ESC N, ESC 0

Horizontal motion:

BS, HT

Print size and character width:

SO, SI, DC4, ESC SO, ESC SI, ESC W

Print enhancement:

ESC -, ESC E, ESC F, ESC G, ESC H, ESC SO, ESC S1, ESC T

Graphics:

ESC K, ESC L, ESC Y, ESC Z

Notes:

- The **FF** command does not work at the top of form position when DIP switch 2-1 is off in IBM emulation mode.
- IBM **emulation** mode graphics are the **same** as Epson **ESC/P** mode graphics except that **ESC ***, **ESC ?**, and **ESC ^** are not **available**.

Commands that differ from Epson ESC/P commands

Printer operation:

ESC Q22

Deselect Printer

Format:

ASCII code:	ESC	Q	22
Decimal:	27	81	22
Hexadecimal:	1B	51	16

Comments:

Takes the printer off line until you turn the printer off and then back on or until the printer receives a **DC1** code.

Vertical motion:

ESC 2

Select Programmable Line Spacing

Format:

ASCII code:	ESC	2
Decimal :	27	50
Hexadecimal:	1B	32

Comments:

Executes the line spacing stored in memory by **ESC A**. If no **ESC A** command has been sent, **ESC 2** sets the line spacing to **1/6** of an inch.

ESC 4

Set Top of **Form**

Format:

ASCII code:	ESC	4
Decimal:	27	52
Hexadecimal:	1B	34

Comments:

Sets the **current** position as top of form.

ESC 5

Turn Automatic Line Feed On/Off

Format:

ASCII code:	ESC	5	<i>n</i>
Decimal:	27	53	<i>n</i>
Hexadecimal:	1B	35	<i>n</i>

Comments:

The following values can be used for *n*:

1: Mode is turned on.

0: Mode is turned off.

If the mode is on, the printer adds a line feed to each carriage return. If the mode is off, it does not. This command duplicates **the function** of DIP switch **2-4**.

ESC A

Set ***n*/72-inch** Line Spacing

Format:

ASCII code:	ESC	A	<i>n</i>
Decimal :	27	65	<i>n</i>
Hexadecimal:	1B	41	<i>n</i>

Comments:

Sets the line spacing to ***n*/72** of an inch. This value is stored in memory until the printer receives the **ESC 2** command to put it into effect. The value of *n* must be from 1 to **85**.

ESC J

Perform **n/216-inch** Line Feed

Format:

ASCII code:	ESC	J	n
Decimal:	27	74	n
Hexadecimal:	1B	4A	n

Comments:

Advances the paper by one line at a line spacing of n/216 of an inch. The value of **n** must be from 0 to **255**. This command produces an immediate line feed but does not affect subsequent line spacing. It does not produce a carriage **return** unless DIP switch **1-3 is off**.

ESC B

Set Vertical Tabs

Format:

ASCII code:	ESC	B	n1	n2	0
Decimal:	27	66	n1	n2	0
Hexadecimal:	1B	42	n1	n2	00

comments:

Sets **up** to **64** vertical tabs in the current line spacing. Tab settings are not affected by subsequent changes **in** line spacing. The tab settings are **entered** as **n1, n2**, etc., all from 1 to **255**, in ascending order. The 0 **character** indicates the end of the command.

ESC B 0 clears **the** tab settings.

*Horizontal motion:***ESC D**

Set Horizontal Tabs

Format:

ASCII code:	ESC	D	<i>n1</i>	<i>n2</i>	0
Decimal :	27	68	<i>n1</i>	<i>n2</i>	0
Hexadecimal:	1B	44	<i>n1</i>	<i>n2</i>					00

Comments:

This command allows setting of up to **28** horizontal tabs, which are entered as *n1*, *n2*, *n3*, etc. (from 1 to **137**) with the 0 character terminating the command. The tab settings must be entered in **ascending** order. **ESC D 0** clears all tabs. The tab settings on power up are **every** eight **characters**. The tab positions change if **the character size is changed**. Only **double-wide mode** does not affect the tab positions.

ESC R

Restore Default Tab Settings

Format:

ASCII code:	ESC	R
Decimal:	27	82
Hexadecimal:	1B	52

Comments:

Resets all vertical and horizontal tab settings (set by **ESC B** and **ESC D**) to their defaults.

ESC X

Set Left and Right Margins

Format:

ASCII code:	ESC	X	n1	n2
Decimal:	27	88	n1	n2
Hexadecimal:	1B	58	n1	n2

Comments:

The left margin column is set to **n1** in the current character size, ignoring double-wide. The right margin column is set to **n2**. The minimum-distance between the two margins is **1/2** inch. The first column is number **1**, not number **0**.

Overall printing style:

ESC I

Select Font

Format:

ASCII code:	ESC	I	n
Decimal:	27	73	n
Hexadecimal:	1B	49	n

Comments:

Sets the font according to the value you specify for **n**. The value of **n** can be any one of the following:

- 0:** Draft quality **10 cpi** font
- 1:** Draft quality **12 cpi** font
- 2:** Near letter quality **Sans** Serif font
- 3:** Near letter quality Roman font
- 4:** Draft quality **10 cpi** user-defined font
- 5:** Draft quality **12 cpi** user-defined font
- 6:** Near letter quality **10 cpi** user-defined font
- 7:** Near letter quality **12 cpi** user-defined font

Print size and character width:

In IBM emulation mode, four modes are incompatible with each other. These modes are **10 cpi**, **12 cpi**, condensed, and proportional. If you select any one of these, you cancel all the others.

DC2Select **10 cpi**

Format:

ASCII code: DC2

Decimal: 18

Hexadecimal: 12

Comments:

Cancels condensed, **12 cpi**, and proportional printing and selects **10 cpi** printing. This **command** does not **cancel double-wide**.

ESC :Select **12 cpi**

Format:

ASCII code: ESC :

Decimal: 27 58

Hexadecimal: 1B 3A

Comments:

Selects **12 cpi** (characters per inch) printing.

ESC PTurn Proportional Mode **On/Off**

Format:

ASCII code: ESC P *n*Decimal : 27 80 *n*Hexadecimal: 1B 50 *n*

Comments:

The following values can be used for *n*:

1: Mode is turned on.

0: Mode is turned off.

The width of proportional characters varies from character to character. **Therefore**, a narrow letter like **i** receives less space than a wide letter like **W**. The proportional widths are **given** in the character tables in the Appendix. **This command overrides** condensed, **10 cpi**, and **12 cpi**.

IBM Emulation Mode Commands Arranged by Topic

ESC [@

Set Double-high/Double-wide **Printing**

Format:

ASCII code: **ESC [@ n1 n2 m1 m2 m3 m4**
Decimal: **27 91 64 n1 n2 m1 m2 m3 m4**
Hexadecimal: **1B 5B 40 n1 n2 m1 m2 m3 m4**

Comments:

You can **use the** following values: **n1=4, n2=0, m1=0, and m2=0**. The value of **m3** affects character **height and** line feeds as shown below:

m3	Character high	Line feed
1	Standard	Unchanged
2	Double-high	Unchanged
16	Unchanged	Single
17	Standard	Single
18	Double-high	Single
32	Unchanged	Double
33	Standard	Double
34	Double-high	Double

The value of **m4** sets the character width.

- 1: Standard
- 2: Double-wide

Print enhancement:

ESC _

Turn **Overscoring** Mode **On/Off**

Format:

ASCII code: **ESC _ n**
Decimal: **27 95 n**
Hexadecimal: **1B 5F n**

Comments:

- You can use the following values for **n**:
- 1: Mode is turned on.
 - 2: Mode is turned off.

Character tables:

ESC 6 Select **International** Character Set

Format:

ASCII code:	ESC	6
Decimal:	27	54
Hexadecimal:	1B	36

Comments:

Selects the international character set (character table **2**). See the IBM emulation **mode** character tables in the **Appendix**.

ESC 7 Select Standard Character Set

Format:

ASCII code:	ESC	7
Decimal:	27	55
Hexadecimal:	1B	37

Comments:

Selects the standard character set (character table **1**). See the IBM emulation **mode** character tables in the Appendix.

ESC ** Print **Characters from Symbol Set

Format:

ASCII code:	ESC	\	n1	n2	data
Decimal:	27	92	n1	n2	data
Hexadecimal:	1B	5C	n1	n2	data

Comments:

Prints a number of characters from the symbol **set**. The number of characters = **n1 + (n2 × 256)**. See the **Appendix** for the symbol set and the codes to use for data.

IBM Emulation Mode Commands Arranged by Topic

ESC ^ Print One Character from Symbol Set

Format:

ASCII code:	ESC	^	c
Decimal:	27	94	c
Hexadecimal:	1B	5E	c

Comments:

Prints a single character (**c**) from the symbol set. See the Appendix for the symbol set and the codes to use for **c**.

User-defined characters:

ESC = Define User-defined Characters

Format:

ASCII code:	ESC	=	n1	n2	nk
Decimal:	27	61	n1	n2	nk
Hexadecimal:	1B	3D	n1	n2	nk

Comments:

If **C** is the total number of characters to be defined,

$$\mathbf{B} = (\mathbf{C} \times 13) + 2$$

$$\mathbf{n1} = \mathbf{B} \text{ MOD } 256$$

$$\mathbf{n2} = \text{INT}(\mathbf{B}/256)$$

$$\mathbf{n3} = 20 \text{ in all cases}$$

$$\mathbf{n4} = \text{the code of the first character to be defined}$$

$$\mathbf{n5} = 0 \text{ if the top 8 pins are used; } \mathbf{n5} = 128 \text{ for the bottom 8 pins}$$

$$\mathbf{n6} = 0 \text{ in all cases}$$

The values **n7** through **nk** are the data numbers that define the characters, with **11** data numbers for each character.

You determine the data numbers for each character as shown on the first grid for **Epson ESC/P mode** in the section on **user-defined characters** in **Chapter 4**. To print a user-defined character, you need to use the **ESC I** command, which is described on **page 9-46**.

Appendix

Proportional Width Table	A-2
Character Tables	A-6
Italic character table	A-7
Epson Extended Graphics character table	A-8
IBM emulation 'mode	A-9

Proportional Width Table

This table lists the widths of your printer's proportional characters. The values given are in **120ths** of an inch. (For example, a value of **12** is **12/120ths** of an inch.) You may need **to enter** these widths into a special table for your word processing program so it can calculate the number of proportional characters that will fit on a line.

The characters with no code indicated are **international characters** or graphics. See the section on selecting an **international** character set in Chapter 3 and the descriptions of the **ESC R** and **ESC t** commands in Chapter 9 for information on how to use these **characters**.

The following width table shows each character, its ASCII code (hexadecimal), and its width. If **there** are two numbers in the width column, the second one is for the italic version of the character.

code	CHR	Width	Code	CHR	Width
20		12/12	30	0	12/12
21	!	5/10	31	1	8/9
22	..	8/10	32	2	12/12
23	#	12/12	33	3	12/12
24	\$	12/11	34	4	12/12
25	%	12/12	35	5	12/12
26	&	12/12	36	6	12/11
27	'	5/5	37	7	12/12
28	(6/8	38	8	12/12
29)	6/8	39	9	12/11
2A	*	12/12	3A	:	6/8
2B	+	12/12	3B	;	6/9
2C	,	7/8	3C	<	10/10
2D	-	12/12	3D	=	12/11
2E	.	6/7	3E	>	10/9
2F	/	10/10	3F	?	12/11



































Proportional Width Table

Code	CHR	Width
40	@	12/12
41	A	12/12
42	B	12/12
43	C	12/12
44	D	12/12
45	E	12/12
46	F	12/12
47	G	12/12
48	H	12/12
49	I	8/10
4A	J	11/12
4B	K	12/12
4C	L	12/10
4D	M	12/12
4E	N	12/12
4F	O	12/12
50	P	12/12
51	Q	12/12
52	R	12/12
53	S	12/12
54	T	12/12
55	U	12/12
56	V	12/11
57	W	12/12
58	X	10/12
59	Y	12/12
5A	Z	10/12
5B	[8/11
5C	\	10/7
5D]	8/11
5E	>	12/10
5F	^	12/12
60	`	5/5
61	a	12/11
62	b	11/11
63	c	11/11

Code	CHR	Width
64	d	11/12
65	e	12/11
66	f	10/12
67	g	11/11
68	h	11/11
69	i	8/9
6A	j	9/10
6B	k	10/11
6C	l	8/9
6D	m	12/11
6E	n	11/10
6F	o	12/11
70	p	11/11
71	q	11/11
72	r	11/10
73	s	12/11
74	t	11/10
75	u	12/11
76	v	12/10
77	w	12/12
78	x	10/12
79	y	12/11
7A	z	10/12
7B	{	9/10
7C		5/9
7D	}	9/10
7E	~	12/12
	Ç	12/12
	ç	11/12
	È	12/11
	è	12/12
	É	12/11
	é	12/11
	Ê	12/11
	ê	12/11
	Ë	11/11
	ë	12/12

Proportional Width Table

Code	CHR	Width
	ë	12/11
	è	12/11
	ì	8/10
	î	10/11
	ï	8/8
	Ä	12/12
	Å	12/12
	É	12/12
	æ	12/12
	Æ	12/12
	ô	10/12
	ö	10/11
	ò	10/11
	û	11/11
	ù	11/11
	ÿ	12/11
	Ö	12/12
	Ü	12/12
	Φ	11/11
	ϕ	12/12
	Ϝ	12/12
	ϝ	12/12
	f	11/12
	á	12/11
	í	8/10
	ó	10/12
	ú	11/11
	ñ	11/12
	Ñ	12/12
	æ	12/11
	œ	12/12
	ö	12/11
	ŕ	12/12
	ŗ	12/12
	ŕ	12/12
	ŕ	12/12
	ı	5/10

Code	CHR	Width
	←	12/12
	→	12/12
B0		12
B1		12
B2		12
B3		12
B4		12
B5		12
B6		12
B7		12
B8		12
B9		12
BA		12
BB		12
BC		12
BD		12
BE		12
BF		12
co		12
CI		12
C2		12
C3		12
C4		12
C5		12
C6		12
C7		12
C8		12
C9		12
CA		12
CB		12
cc		12
CD		12
CE		12
CF		12
Do		12
D1		12
D2		12

Proportional Width Table

Code	CHR	Width
D3	ℓ	12
D4	ℓ	12
D5	ℓ	12
D6	ℓ	12
D7	ℓ	12
D8	ℓ	12
D9	ℓ	12
DA	ℓ	12
DB	ℓ	12
DC	ℓ	12
DD	ℓ	12
DE	ℓ	12
DF	ℓ	12
E0	ℓ	12/12
E1	ℓ	11/11
E2	ℓ	10/12
E3	ℓ	12/12
E4	ℓ	10/12
E5	ℓ	11/12
E6	ℓ	11/12
E7	ℓ	12/12
E8	ℓ	10/12
E9	ℓ	12/12
EA	ℓ	12/12
EB	ℓ	12/11
EC	ℓ	12/12
ED	ℓ	12/12
EE	ℓ	10/10
EF	ℓ	10/12
F0	ℓ	12
F1	ℓ	12
F2	ℓ	10
F3	ℓ	10
F4	ℓ	12
F5	ℓ	12
F6	ℓ	12
F7	ℓ	12

Code	CHR	Width
F8	◦	8
F9	◦	6
FA	◦	6
FB	√	12
FC	n	8
FD	2	8
FE	■	8
	◦	8/8
	α	12/12
	β	11/11
	∅	12/12
	0	12/11
	·	8/9
	8	10/12

Character Tables

You can select the character tables in this section by setting DIP switch 1-3 or using the ESC t software command.

In the tables, the first digit of each hex code is in the top row and the second digit is in the first column. The binary digits are in the second row and second column, and the decimal codes are in the rectangle next to the character. For example, for an uppercase A, the hex code is 41, the binary code is 01000001, and the decimal code is 65.

Note: The printer can print the characters in the shaded areas only if you send the ESC 6 command to the printer. If you do not send the ESC 6 command, the shaded areas contain the control codes in the range of 0 to 31 and 127.

	Hex. No.	0	1	2	3	4	5	6	7	8	9	A	B	C	D	E	F
Hex. No.	Binary No.	0000	0001	0010	0011	0100	0101	0110	0111	1000	1001	1010	1011	1100	1101	1110	1111
0	0000	<i>NU</i>		<i>SP</i>	0	⊙	P		P				<i>O</i>	⊙	<i>P</i>		<i>p</i>
		0	16	32	48	64	80	96	112			160	176	192	208	224	240
1	0001		<i>DC1</i>	!	1	A	Q	a	q			!	<i>I</i>	<i>A</i>	<i>Q</i>	<i>a</i>	<i>q</i>
		1	17	33	49	65	81	97	113			161	177	193	209	225	241
2	0010		<i>DC2</i>	"	2	B	R	b	r			"	<i>2</i>	<i>B</i>	<i>R</i>	<i>b</i>	<i>r</i>
		2	18	34	50	66	82	98	114			162	178	194	210	226	242
3	0011		<i>DC3</i>	#	3	C	S	c	s			#	<i>3</i>	<i>C</i>	<i>S</i>	<i>c</i>	<i>s</i>
		3	19	35	51	67	83	99	115			163	179	195	211	227	243
4	0100		<i>DC4</i>	\$	4	D	T	d	t			\$	<i>4</i>	<i>D</i>	<i>T</i>	<i>d</i>	<i>t</i>
		4	20	36	52	68	84	100	116			164	180	196	212	228	244
5	0101			%	5	E	U	e	u			%	<i>5</i>	<i>E</i>	<i>U</i>	<i>e</i>	<i>u</i>
		5	21	37	53	69	85	101	117			165	181	197	213	229	245
6	0110			&	6	F	V	f	v			&	<i>6</i>	<i>F</i>	<i>V</i>	<i>f</i>	<i>v</i>
		6	22	38	54	70	86	102	118			166	182	198	214	230	246
7	0111	<i>DEL</i>		'	7	G	W	g	w			'	<i>7</i>	<i>G</i>	<i>W</i>	<i>g</i>	<i>w</i>
		7	23	39	55	71	87	103	119			167	183	199	215	231	247
8	1000	<i>BS</i>	<i>CAN</i>	(8	H	X	h	x			(<i>B</i>	<i>H</i>	<i>X</i>	<i>h</i>	<i>x</i>
		8	24	40	56	72	88	104	120			168	184	200	216	232	248
9	1001	<i>HT</i>	<i>EM</i>)	9	I	Y	i	y)	<i>9</i>	<i>I</i>	<i>Y</i>	<i>i</i>	<i>y</i>
		9	25	41	57	73	89	105	121			169	185	201	217	233	249
A	1010	<i>LF</i>		*	10	J	Z	j	z			*	<i>10</i>	<i>J</i>	<i>Z</i>	<i>j</i>	<i>z</i>
		10	26	42	58	74	90	106	122			170	186	202	218	234	250
B	1011	<i>VT</i>	<i>ESC</i>	+	11	K	[k	{			+	<i>11</i>	<i>K</i>	<i>[</i>	<i>k</i>	<i>{</i>
		11	27	43	59	75	91	107	123			171	187	203	219	235	251
C	1100	<i>FF</i>		<	12	L	\	l				,	<i>12</i>	<i>L</i>	<i>\</i>	<i>l</i>	<i> </i>
		12	28	44	60	76	92	108	124			172	188	204	220	236	252
D	1101	<i>CS</i>		=	13	M]	m	}			-	<i>13</i>	<i>M</i>	<i>]</i>	<i>m</i>	<i>}</i>
		13	29	45	61	77	93	109	125			173	189	205	221	237	253
E	1110	<i>SO</i>		>	14	N	^	n	~			.	<i>14</i>	<i>N</i>	<i>^</i>	<i>n</i>	<i>~</i>
		14	30	46	62	78	94	110	126			174	190	206	222	238	254
F	1111	<i>SI</i>		/	15	O	_	o	DEL			/	<i>15</i>	<i>O</i>	<i>_</i>	<i>o</i>	<i>DEL</i>
		15	31	47	63	79	95	111	127			175	191	207	223	239	255

Italic character table

Epson Extended Graphics character table

	Hex. No.	0	1	2	3	4	5	6	7	8	9	A	B	C	D	E	F
Hex. No.	Binary No.	0000	0001	0010	0011	0100	0101	0110	0111	1000	1001	1010	1011	1100	1101	1110	1111
0	0000	NUL 0		SP 16	0 32	@ 48	P 64	` 80	p 96			á 160	 176	L 192	ll 208	α 224	≡ 240
1	0001		DC1 1	! 17	1 33	A 49	Q 65	a 81	q 97			í 161	 177	L 183	ƒ 209	β 225	± 241
2	0010			DC2 16	" 34	2 50	B 66	R 82	b 98			ó 162	 178	T 194	ll 210	Γ 226	≥ 242
3	0011			DC3 19	# 35	3 51	C 67	S 83	c 99			ú 163	 179	 195	ll 211	π 227	∇ 243
4	0100			DC4 20	\$ 36	4 52	D 68	T 84	d 100			ñ 164	 180	- 196	ll 212	Σ 228	f 244
5	0101		8 21	% 37	5 53	E 69	U 85	e 101	u 117			ñ 165	 181	 197	ƒ 213	σ 229	J 245
6	0110			& 38	6 54	F 70	V 86	f 102	v 118			a 166	 182	ƒ 198	ll 214	ll 230	÷ 246
7	0111	BEL 7		' 39	7 55	G 71	W 87	g 103	w 119			o 167	ll 183	 199	 215	T 231	≈ 247
8	1000	BS 8	CAN 24	(40	8 56	H 72	X 88	h 104	x 120			ò 168	 184	ll 200	† 216	Φ 232	° 248
9	1001	HT 9	EM 25) 41	9 57	I 73	Y 89	i 105	y 121			ƒ 169	 185	ll 201	J 217	Θ 233	° 249
A	1010	LF 10		* 42	: 58	J 74	Z 90	j 106	z 122			→ 170	 186	ll 202	Γ 218	Ω 234	° 250
B	1011	VT 11	ESC 27	+ 43	: 59	K 75	[91	k 107	[123			¼ 171	ll 187	ll 203	 219	δ 235	ƒ 251
C	1100	FF 12		, 44	< 60	L 76	\ 92	l 108	l 124			½ 172	ll 188	ll 204	 220	∞ 236	n 252
D	1101	CR 13		- 45	= 61	M 77] 93	m 109] 125			i 173	ll 189	= 205	 221	ø 237	° 253
E	1110	SO 14		. 46	> 62	N 78	^ 94	n 110	~ 126			← 174	J 190	ll 206	 222	€ 238	° 254
F	1111	SI 15		/ 47	? 63	O 79	- 95	o 111	DEL 127			→ 175	 191	ll 207	 223	∩ 239	

IBM emulation mode

IBM emulation mode provides compatibility with application programs written **specifically for IBM printers**. To select IBM emulation mode, turn on DIP switch 1-4.

In IBM **emulation** mode, you can select a standard character set (character table 1) or an **international** character set (character table 2). To **select** character table 1, **turn** on DIP switches 1-6, 1-7, and 1-8. To select character table 2, **turn** off any one of these switches. You can also select character table 1 using the **ESC 7** command or character table 2 using the **ESC 6** command.

Character table 2 is shown below. To form character table 1, replace the characters in the shaded column with the characters for code 00 to 1F in the column on the left.

IBM emulation mode character table 2

CODE	0	1	2	3	4	5	6	7	8	9	A	B	C	D	E	F
0	NUL		0	@	P	`	p		á		⊥	⊥	α	≡		
1	DC1	!	1	A	Q	a	q		í		⊥	⊥	β	±		
2	DC2	"	2	B	R	b	r		ó		⊥	⊥	Γ	∞		
3		#	3	C	S	c	s		ú		⊥	⊥	π	∞		
4	DC3	\$	4	D	T	d	t		ñ	⊥	⊥	⊥	Σ	⊥		
5		%	5	E	U	e	u		ñ	⊥	⊥	⊥	σ	⊥		
6		&	6	F	V	f	v		⊥		⊥	⊥	μ	+		
7	BEL	'	7	G	W	g	w		o	π			τ	≈		
8	BS CAN	(8	H	X	h	x		o	⊥	⊥	⊥	⊥	⊥	°	
9	HT)	9	I	Y	i	y		⊥		⊥	⊥	⊥	⊥	°	
A	LF	*	:	J	Z	j	z		⊥		⊥	⊥	⊥	⊥	°	
B	VT ESC	+	;	K	[k	{		⊥	⊥	⊥	⊥	⊥	⊥	°	
C	FF	,	<	L	\	l			⊥	⊥	⊥	⊥	⊥	⊥	°	
D	CR	-	=	M]	m	}		⊥	⊥	⊥	⊥	⊥	⊥	°	
E	s	o	.	>	N	^	n	~	⊥	⊥	⊥	⊥	⊥	⊥	°	
F	SI	/	?	O	_	o			⊥	⊥	⊥	⊥	⊥	⊥	°	

Character Tables

Symbol set

In IBM **emulation** mode, a **symbol set** in which all codes are printable can be used. To print symbol characters, use the ESC \ or ESC ^ command. (See pages 9-49 and 9-50.)

IBM emulation mode *symbol set*

CODE	0	1	2	3	4	5	6	7	8	9	A	B	C	D	E	F
0	Ø	▶		0	@	P	˘	p	Ç	È	á	⋮	L	ll	α	≡
1	⊙	◀	!	1	A	Q	a	q	ü	æ	í	⋮	⊥	⊟	β	±
2	⊙	‡	"	2	B	R	b	r	é	Æ	ó	⋮	⊥	⊟	Γ	≥
3	♥	!!	#	3	C	S	c	s	à	ø	ú		⊥	ll	π	≤
4	♦	π	\$	4	D	T	d	t	ä	ö	ñ	⊥	-	ll	Σ	∫
5	♣	5	%	5	E	U	e	u	à	ò	Ñ	⊥	⊥	⊟	σ	∫
6	♣	-	&	6	F	V	f	v	ä	û	ä		⊥	⊟	μ	÷
7	·	±	˘	7	G	W	g	w	ç	ù	o	π			τ	≈
6	□	↑	(8	H	X	h	x	ê	ÿ	¿	⊥	ll	⊥	Φ	°
9	o	↓)	9	I	Y	i	y	ë	Ö	⊥		⊟	⊥	θ	•
A	⊙	→	*	:	J	Z	j	z	è	Ü	⊥		ll	⊥	Ω	•
B	♂	←	+	;	K	[k	{	ï	ç	½	π	⊟	■	δ	√
C	♀	⊥	,	<	L	\	l	!	î	£	¾	ll		■	ω	∞
D	♪	⊕	-	=	M]	m	}	ï	¥	;	ll	=	■	ø	•
E	♂	▲	.	>	N	^	n	~	À	℞	<	⊥		■	ε	•
F	♂	▼	/	?	O	_	o	△	À	f	>	⊥	ll	■	∩	

Glossary

The following definitions apply specifically to printers.

application program

A **software program** that **helps you carry** out a particular task, such as word **processing** or financial planning.

ASCII

American Standard Code for Information Interchange. A standardized coding system for **assigning** numerical codes to letters and symbols.

auto line feed

When this feature is selected using a DIP switch, each carriage return code (CR) is automatically followed by a line feed (**LF**) code.

baud rate

A measure of the speed of data transmission. Usually expressed in bits per second (bps).

bidirectional printing

Printing in which the print head moves from left to right on every other line and from right to left on the others. This increases the printing speed.

binary

See number systems.

bit

A binary digit (**0** or **1**), which is the smallest unit of information used by a printer or computer. See **also** number systems.

buffer

See memory.

byte

A unit of information consisting of eight bits.

carriage return

The control code that returns the print position to the left margin. When issued together with a line feed, the print **position** moves to the left margin of the next line. (In bidirectional printing, the print head does not always move to the left margin.)

character set

A collection of letters, numbers, and symbols that provides you with the characters used in a particular language.

character **table**

A portion of the printer's standard ASCII character set that can be used for graphic symbols or italic characters. See **also** Epson Extended Graphics character table **and** italic.

characters per inch (cpi)

A measure of the size of text characters. **10 cpi** is the printer's default setting.

condensed

Printing in which each character is approximately **60%** of the width of standard characters. Condensed printing is useful when printing wide tables or spreadsheets.

continuous paper

Paper that has sprocket-feed holes on each side, is perforated between pages, and comes in a **folded** stack. Also called fanfold paper.

control code

In addition to the codes for printable characters, the ASCII coding system includes **33** codes called control codes. These control codes perform such functions **as** sounding the beeper and **performing** a carriage **return** or line feed.

copy mode

A feature that causes the printer to print clearer, darker **characters** on each page of **your** multi-part forms.

cpi

See characters per inch.

data dump

A troubleshooting feature that helps advanced users find the cause of **communication** problems **between** the **printer and** the computer. When the printer is in data dump mode, it **prints each** code it receives in hexadecimal notation and ASCII code. **Also** called **hex** dump.

decimal

See number systems.

default

A value or setting that takes effect when **the equipment** is turned on, reset, or initialized.

DIP switches

Small switches in a printer that control various printer functions and set the default status of the printer when it is **turned** on or initialized. DIP stands for dual in-line package,

dot graphics

A **graphic** design **formed** by **patterns** of dots. Also called bit image graphics.

dot matrix

A method of printing **in** which each letter or symbol is formed by a **pattern (matrix) of individual dots**.

double-high printing

Printing in which each character is twice as tall as normal.

double-strike printing

A way of producing bolder **characters**. Each character is printed twice, with the second character printed slightly below the first.

double-wide printing

Printing in which **each** character is twice its normal width.

draft (normal draft)

One of three print **qualities available on your printer**. Draft uses less dots **per character for faster** printing. See *also* high-speed draft *and* near letter quality.

emphasized printing

A way of producing darker characters. Each character is printed twice, with the second character printed slightly to the right of the first.

Epson Extended Graphics

The Epson Extended Graphics character table contains **international** accented characters, **Greek characters**, and character graphics for printing **lines**, comers, and shaded areas.

ESC (escape)

A special control code used to begin most **printer** commands.

ESC/P

Abbreviation for Epson **Standard Code for Printers**, a system of **commands** that lets you control your printer using your computer's software. **The system is standard for all Epson printers** and supported by most application software for personal computers.

font

A style of type designated by a family name, such as Epson Roman or Epson **Sans** Serif.

form

In **printer** terminology, a form **normally** refers to a page.

form feed

A control code **and** a control panel button. Each advances the paper to the top of **the next page**.

front tractor

The built-in push **tractor** that lets you load paper from the front of the **printer**. This tractor features bottom **feeding**, which is especially useful for labels and **multi-part** forms.

front tractor arrow

The arrow-shaped light on **the PAPER SELECT indicator** that lights up when the front tractor is selected. The arrow is green **when paper** is loaded in the tractor, even if the paper is in the standby position, and red when the **tractor** is out of paper.

FRONT/REAR button

A **control** panel button that lets you switch tractors automatically.

hexadecimal (hex)

See number systems.

high-speed draft

One of three **print** qualities **available** on your printer. High-speed draft uses a **minimum** number of dots per character to produce extremely high-speed printing. See **also** draft **and** near letter quality.

initialize

To establish the initial default status **of the printer by turning on** the printer or sending an **INIT** signal.

input buffet

See memory

interface

The connection between the computer and the printer. A parallel interface transmits **data one character or code at a time, and a serial interface transmits data one bit at a time.**

italics

A **typestyle** in which the characters slant. *This sentence* is italicized. Also, a character table that contains italicized characters and symbols.

line feed

A control code that advances the **paper** one line space.

LINE FEED/LOAD button

A control panel button that advances the paper one line or automatically loads paper.

loading position

The position to which the paper is automatically loaded. It can be adjusted using the micro-adjustment feature.

memory

The printer, like a computer, has a memory. When you print a file from the computer, the contents of the file are **transferred quickly** from the computer's memory to the printer's memory. The printer then prints information from its own memory. This **frees the computer** to do other work while the **printer** is printing., The printer memory is sometimes called the buffer or the input **buffer**.

micro-adjustment

A feature you can use to adjust the top of form, short tear-off, loading, and printing positions.

near letter quality (NLQ)

One of three **print qualities** available on your **printer**. Near letter quality reduces **the** print speed and increases the number of dots per character to **produce** high-resolution characters. See also draft **and** high-speed draft.

number systems

Three number systems are commonly used with printers:

Decimal is base **10** and uses the digits 0 through **9**. (This is the most familiar system.)

Hexadecimal (hex) is base **16** and uses the 'digits 0 through 9 and the letters A through **F**. **Programmers** frequently use this numbering **system**. Any decimal number between 0 and **255** can be expressed by a two-digit hex number.

Binary is base **2** and uses only the digits 0 and **1**. All **information** in computer systems is handled in binary form to represent electrical signals that are on or off. A binary digit is often called a bit; any decimal number **between** 0 and **255** can be expressed by an eight-bit binary number.

on line

When the **printer** is on line, it can communicate with the computer connected to it; The **ON LINE** button **controls** the printer's on line/off line **status**.

paper bail

The part of the printer **that** holds the paper flat.

paper cutter

An optional device that automatically cuts off printed documents.

paper memory

A feature that produces high quality printing on your multi-part forms by **using** stored paper **format** and **thickness** information to adjust the print head.

paper-out sensor

A small switch on the **tractors** that sends a **signal** when it is not in contact with paper, **causing** the **PAPER OUT** light to go on.

paper select indicator

The **printer** icon on the control panel that contains the front and rear tractor **arrows**. These **arrows** light up to show which tractor is selected. See also **front tractor arrow** *and* **rear tractor arrow**.

parallel interface

A type of connection between the computer **and** the **printer**. A parallel **interface** transmits data one character ox code at a **time**.

parity

A method for a computer and **printer** to check the reliability of data transmission.

platen

The **silver** plate behind the **paper** bail that provides a backing fox the printing.

print quality

Your printer has three types of **print** quality: draft, high-speed draft, and **near** letter quality (**NLQ**). Draft and high-speed draft axe for high-speed, **draft-quality** jobs; **NLQ** is for final, polished **documents**.

proportional printing

Printing in which the amount of space given to each character **varies**. For example, an **uppercase W** receives much more space than a **lowercase i**. The **result** looks more like a typeset book than a **typewritten** draft.

pull tractor

An optional **paper** feeder that is useful when **printing** on **preprinted** ox multi-part **forms**.

push tractor

A device that feeds continuous paper through the printer. Both the front and rear built-in tractors are push tractors; they *push* the paper through the printer to the print head.

RAM

Random Access Memory. The portion of the printer's memory that is used as a buffer and as a place for storing **user-defined** characters.

rear tractor

The built-in push tractor that feeds paper from the rear of the printer.

rear tractor arrow

The arrow-shaped light on the PAPER SELECT indicator that lights up when the rear tractor is selected. The arrow is green when paper is loaded in the tractor, even if the paper is in the standby position, and red when the tractor is out of paper.

reset

To return a printer to its defaults by sending a command or an **INIT** signal or by **turning** the printer off and then back on.

self test

A method of checking the operation of the printer. When the self test is run, the printer prints its current DIP switch settings and the characters that are stored in its ROM (Read Only Memory).

serial interface

A type of connection between the computer and the printer. A serial interface transmits data one bit at a time.

short tear-off

A feature that feeds the paper's perforation to the tear-off position and then feeds the paper back to the loading position. You can change the tear-off position using the micro-adjustment feature.

standby position

The position the paper is in after you manually load it onto the first few pins of the tractor sprockets. When the printer switches tractors, it feeds the paper on the previously selected tractor back to this position.

subscripts

Printing in which each character is printed at about two-thirds the normal height in the lower part of the character space.

superscripts

Printing in which each character is printed at about two-thirds the normal height in the upper part of the character space.

10 cpi

A character spacing with **10** characters per inch. This is **the printer's** default character spacing.

TEAR OFF button

A button that lets you use the short tear-off feature. See short tear-off.

tear-off position

The position the printer feeds the paper **to** when you press **the TEAR OFF** button. Using the micro-adjustment feature, you can adjust this position so that the paper's perforation meets the printer's tear-off edge.

top of form position

The position on the paper that the printer recognizes as the first printable line. The printer feeds **the** paper to this position when it loads the paper. You can change this position using the **micro-adjustment** feature.

tractor

The part of the printer that feeds continuous paper through the printer by gripping the holes along the paper's sides.

12 cpi

A character spacing in which each character is slightly narrower than normal, so that there are **12** characters per inch.

unidirectional printing

Printing in one direction only. Unidirectional printing is useful for printing graphics because it allows more precise vertical alignment than bidirectional printing.

user-defined characters

Characters that are defined and stored in the printer by the user. Also known as download characters.

Index

A

- Application programs, 1-36
- ASCII, 9-3
- Assembling the printer, **1-9—12**
- Auto line feed,
 - setting with DIP switch, 3-11, 3-15

B

- Bail, paper, 5-5, 5-14
- BASIC, 4-15, 9-3
- Baud rate. See Serial interface
- Beeper, 9-12
- Bidirectional printing, 8-2, 9-10
- Bit image graphics. See Graphics
- Bottom margin. See Skip over perforation
- Brackets, locking, 1-5, 6-11
- Buffer, 3-12, 3-16, 8-3
- Buttons, **3-4—6**
 - FORM FEED/COPY, 3-4
 - LINE FEED/LOAD, 3-4, 3-5
 - MICRO FEED**, 3-4, 3-5
 - ON LINE, 3-4
 - FRONT/REAR (PAPER SELECT), 3-4, 3-6
 - TEAR OFF, 3-4, 3-5
 - TOP OF FORM, 3-4, 3-5
- Buzzer. See Beeper

C

- Cable,
 - parallel interface, **1-27—30**
 - power, 1-3, **1-13—14**
 - serial interface, **1-31—35**
- Carbon paper See Multi-part forms
- Character fonts, **3-43—44**, **4-2—3**, 8-3, 9-46
- Character size, 4-4, **9-25—28**, **9-46—48**
- Character spacing, 3-45, **4-3—4**, 9-25, 9-47
- Characters per inch, 3-45, 4-3, **8-2—3**
- Character tables, **3-49—50**, A-6-10
 - setting with DIP switches, 3-11, 3-13, **3-49—50**
 - setting with software commands, 9-34, 9-49
- Choosing a place for the printer, 1-7--8
- Choosing** from a menu, 1-3 6-3 7
- Cleaning the printer, **6-2—3**
- Coax interface, 6, 5-32, 5-33
- Commands,
 - arranged by topic, **9-9—50**
 - description of command format, 9-3
 - in numerical order, **9-5—8**

- Computer, connecting to, 1-26-35
- Condensed printing, 3-46, 4-5
 - setting with DIP switch, 3-11, 3-46
 - setting with software command, 9-26
- Connecting to computer, 1-26-35
- Continuous paper. See Paper
- Control panel, **3-2—6**
- Copy capacity, 8-9
- Copying ROM to RAM, **4-27—28**,
- Copy mode, 2-29
- Country. See International character sets
- Cover,
 - front, 1-15
 - paper separator, 1-22
 - rear, 1-27
 - top, 1-4
- Cpi. See characters per inch

- D
- Data dump mode, **3-51—53**
- Default settings, 8-17--8
- Dimensions of printer, 8-9
- DIP switches, **3-7—16**
- Double-high printing, 4-4, 9-28, 9-48
- Double-strike printing, 4-5--6, 9-30
- Double-wide printing, 4-4, **9-27—28**, 9-48

- Download. See User-defined characters
- Draft mode,
 - self test, 1-20, 1-23
- Draft printing speed, 1-23, 3-11, 3-14

- E
- Electrical specifications, 8-10
- Elite. See Character spacing
- Emphasized printing, **4-5—6**, 9-29
- Enhancing your printing, **4-2—9**
- Environmental specifications, 8-10
- Epson Extended Graphics character table, 3-11, **3-49—50**, 9-34, A-8
 - setting with DIP switch, 3-11, **3-49—50**
 - setting with software command, 9-34
- Escape (ESC) codes, See commands

- F
- Fonts, **3-43—44**, **4-2—3**, 9-23, 9-46
- Foreign language characters. See International characters
- FORM FEED button, 3-4
- FRONT/REAR button, 3-4, 3-6
- Front tractor, loading paper on, **2-4—10**

G

Graphics, command, **4-10—21, 9-38—40**

Graphics character table. See Epson Extended Graphics character table

Guide, ribbon, 1-10, 6-6

H

Hexadecimal (hex) dump. See Data dump mode

Hexadecimal, 9-8, 9-3

High-speed draft, 1-23, 3-43

I

IBM emulation mode,
DIP switches, 3-11, 3-13,
3-14, A-9
software commands, **9-41—50**

IEEE-488 interfaces, 5-32, 5-33

Indicator lights, **3-2—3**

Initialization, **8-17—18**

Input buffer, 3-12, 3-16, 8-3

Interface,

optional, **5-32—40**

parallel, **1-27—30, 8-11—14**

serial, **1-31—35, 8-15—16**

specifications, **8-11—16**

timing, 8-14

Interface boards, **5-32—40**

choosing, 5-32

installing, **5-33—39**

New Serial interface board
(# 8143), **5-39—40**

optional, **5-32—40**

International character sets,
setting with DIP switches,
3-12, **3-47—48**

setting with software
commands, 3-48, 9-34, 9-49

Italic character table, 3-11,
3-49—50, 9-34, A-7

setting with DIP switch, 3-11,
3-49—50

setting with software
command, 9-34

Italic printing, 4-6, **9-31—32**

J

Justification, 9-33

L

Labels, **2-32—33, 8-5—7**

Lights, **3-2—3**

LINE FEED/LOAD button, 3-4, 3-5

Line spacing, **9-15—17,**
9-42—44

Loading paper

continuous paper, **2-4—19**

labels, **2-32—33**

pull tractor, **5-5—15**

switching between front and
rear tractor, **2-20—23,**
5-26—27

Loading position,
adjusting, 3-36

Location for printer, 1-7-8

Locking brackets, 1-5, 6-11

M

- Maintaining the printer, **6-2—12**
- Margins, **9-19—20**, 9-46
- Master Select, **4-8—9**, 9-24
- Maximum paper widths, 8-5
- Mechanical specifications, 8-9
- MICRO FEED** button, 3-4, 3-5
- Moving the printer, 1-2,
6-9—12
- Multi-part forms, **2-30—31**,
3-20—32, 8-8-9
 - overlapping, **2-31**, **3-20—23**,
8-7
 - with labels, 2-31, **3-24—29**,
8-8

N

- Near letter quality (NLQ), 1-20,
1-24, **3-43—44**, **4-2—3**
- Normal draft, 1-24, 3-44, 4-2

O

- ON LINE**,
 - button, **3-4**
 - light, **3-2—3**
- Options,
 - interface boards, **5-32—40**
 - paper cutter, **5-19—31**
 - pull tractor, **5-2—18**

P

- Page length, 3-17
 - setting with DIP switch, 3-12,
3-17
 - setting with software
commands, **9-13—14**
- Panel, control, **3-2—5**
- Paper,
 - loading continuous paper,
2-4—19
 - positioning, **2-2—3**
 - specifications, **8-3—9**
 - switching between front and
rear tractor, **2-20—23**,
5-26—27, 9-12
 - thickness, 8-6
- Paper bail, 5-5, 5-14
- Paper cutter, **5-19—31**
 - installing, **5-19—22**
 - paper handling, **5-23—28**
 - removing, **5-28—31**
- Paper handling,
 - continuous paper, **2-2—28**
 - labels, **2-32—33**
 - multi-part forms, **2-30—31**
 - paper cutter, **5-23—28**
 - pull tractor, **5-5—15**
- Paper memory, **3-20—32**
- PAPER OUT** light, 3-2, 3-3
- PAPER SELECT** panel, 3-2, 3-3
- Paper separator, 5-3, 5-17, 5-18
 - with pull tractor, 5-3, 5-17,
5-18

- Papertickness, 8-6
 - Paper weight, 8-6
 - Paper width, 8-5
 - Parallel interface,
 - connecting, **1-27—30**
 - DIP switch settings, 3-13
 - pin assignments, **8-11—14**
 - specifications, **8-11—14**
 - timing, 8-14
 - Parity, 3-13, 3-15
 - Parts, printer, see the inside of
 - the back cover of this 'manual
 - Pica. See Character spacing
 - Pin assignments, **8-11—14**, 8-16
 - Pitch. See character spacing
 - Place, choosing, 1-7-8
 - Plugging in printer, **1-13—14**
 - Positioning paper supply,
 - 2-2—3**
 - Power cable, 1-3, **1-13—14**
 - POWER light, 3-2
 - Power supply, connecting to,
 - 1-13—14**
 - Print direction, 8-2, 9-10
 - Print head,
 - life, 8-9
 - operation when printing
 - graphics, **4-11—14**
 - protector, 1-5, 6-12
 - Printquality, **4-2—3**
 - Printer,
 - cleaning, **6-2—3**
 - options, **5-2—40**
 - parts, see the inside of the
 - back cover of this manual
 - plugging in, **1-13—14**
 - selection menu, 1-36-37
 - setting up, 1-2-37
 - specifications, **8-2—10**
 - stand, 1-8
 - testing **1-13—25**
 - transporting **6-9—12**
 - troubleshooting, **7-2—23**
 - unpacking, 1-2-6
 - weight, 8-9
 - Printer selection menus,
 - 1-36-37
 - Printer stand, 1-8
 - Printing position,
 - adjusting, **3-37—39**
 - Printing speed, 8-2
 - Problems and solutions,
 - 1-24-25, **7-2—23**
 - Proportional,
 - spacing, 3-45, **4-3—4**, 9-25,
 - 9-47
 - width tables, **A-2—5**
 - Protective materials, 1-4-6,
 - 6-11—12**
 - Pull tractor, **5-2—18**
 - installing **5-2—7**
 - paper handling, **5-7—15**
 - removing, **5-15—18**
- ## R
- READY light, 3-2
 - Rear tractor, loading paper on,
 - 2-11—19**
 - Ribbon,
 - guide, 1-10, 6-6
 - installing **1-9—12**

life, 8-9
replacing, **6-4-8**
Roman, **3-43-44**, 4-2, 9-23,
9-46
RS-232C-compatible serial
i n t e r f a c e , 5-32

S

Sans Serif, 3-43--44, 4-2, 9-23,
9-46
Self test,
running, **1-15-24**
solving any problems,
1-24-25

Sending commands to the
printer, **9-3-4**

Serial interface(s),
connecting, 1-31-35
DIP switch settings, 3-13
pin assignments, 8-16
specifications, **8-15-16**

Setting up the printer, 1-2-37

Short tear-off,
adjusting, **3-35-37**

Size, character, 4-4, **9-25-28**,
9-46-48

Skip over perforation, **3-18-19**
setting with DIP switch, 3-3,
3-18

setting with software
command, **9-14-15**

Slashed zero, 3-11, 3-14

Software. See Application
program

Software commands, **9-2-50**

Solutions, 1-24-25, 7-2-23
Special effects and emphasis,
4-5-7

Special paper,
printing on, **2-29-33**

Specifications,
interface, **8-11-16**
printer, **8-2-10**

Stand, printer, 1-8

Subscript, 4-7, **9-30-31**

Superscript, 4-7, **9-30-31**

Switches, DIP, **3-6-14**

T

TEAR OFF,
button, 3-4, 3-5
light, 3-2, 3-3

Tear-off mode, 3-5, **3-35-37**

Tear-off position, 3-5, **3-35-37**

Technical specifications, **8-2-18**

Testing,
self test, **1-15-25**
using data dump mode,
3-51-53

Timing, parallel interface, 8-14

TOP OF FORM,
button, 3-4, 3-5
light, 3-2, 3-3

Top of form position, **3-29-32**

Tractor,
arrow lights, 3-2, 3-3
front, **2-4-10**
pull, **5-2-18**
rear, **2-11-19**

switching between front and rear, **2-20—23**, **5-26—27**, 9-12

Transporting the printer, **6-9—12**

Troubleshooting, 7-2-23

Twinax interface, 6, 5-32, 5-33

Typstyles,
character fonts, **3-43—44**, 4-2--3, 8-3, 9-46
character spacing, 3-45, **4-3—4**, 9-25, 9-47
selecting with Master Select, **4-8—9**, 9-24
special effects and emphasis, **4-5—7**

U

Underlining, 4-7, 9-32

Unidirectional printing, 8-2, 9-10

Unpacking, 1-2-6

User-defined characters, **4-22—28**, **9-36—37**, 9-50

V

Voltage, 8-10
power supply, **1-13—14**

W

Weight, printer, 8-9

Width detection, 2-2

Word processing, 9-33

Z

Zero, slashed, 3-11, 3-14

EPSON[®]

DFX-8000

Quick Reference

Commands Arranged by Topic

This section lists all the DFX commands. The numbers in the columns on the right are the page numbers in Chapter 9 where you can find a complete description of the command. If the Epson ESC/P and IBM emulation mode page numbers are the same, the command is the same in both **modes** and is described only in the Epson ESC/P mode section. Variables are not included in this quick reference. For those codes that contain variables, such as ESC Q n for setting the right margin, see Chapter 9.

Printer operation

ASCII	Dec	Hex	Description	ESC/P page	IBM page
ESC @	64	40	Initialize Printer	9-9	
DC1	17	11	Select Printer	9-9	9-9
DC3	19	13	Deselect Printer	9-10	9-10
ESC Q22	81	51	Deselect Printer		9-42
ESC <	60	3C	Select Unidirectional Mode (one line)	9-10	
ESC U	85	55	Turn Unidirectional Mode On/Off	9-10	9-10
ESC =	61	3D	Set MSB to 0	9-11	
ESC >	62	3E	Set MSB to 1	9-11	
ESC #	35	23	Cancel MSB Control	9-11	
ESC EM	25	19	Select Paper Path	9-12	
BEL	7	07	Beeper	9-12	9-12

Data control

ASCII	Dec	Hex	Description	ESC/P page	IBM page
CR	13	0D	Carriage Return	9-12	9-12
CAN	24	18	Cancel Line	9-13	9-13
DEL	127	7F	Delete Character	9-13	

Vertical motion

ASCII	Dec	Hex	Description	ESC/P page	IBM page
FF	12	0C	Form Feed	9-14	9-14
ESC C	67	43	Set Page Length in Lines	9-13	9-13
ESC C 0	67	43	Set Page Length in Inches	9-14	9-14
ESC N	78	4E	Set Skip Over Perforation	9-14	9-14
ESC 0	79	4F	Cancel Skip Over Perforation	9-15	9-15
ESC 4	52	34	Set Top of Form		9-43
LF	10	0A	Line Feed	9-15	9-15
ESC 0	48	30	Select 1/8-inch Line Spacing	9-15	9-15
ESC 1	49	31	Select 7/72-inch Line Spacing	9-16	9-16
ESC 2	50	32	Select 1/6-inch Line Spacing	9-16	
ESC 2	50	32	Select Programmable Line Spacing		9-42
ESC 3	51	33	Set n/216-inch Line Spacing	9-16	9-16
ESC A	65	41	Set n/72-inch Line Spacing	9-17	
ESC A	65	41	Set n/72-inch Line Spacing		9-43
ESC J	74	4A	Perform n/216-inch Line Feed	9-17	9-44
ESC 5	53	35	Turn Automatic Line Feed On/Off		9-43
VT	11	0B	Tab Vertically	9-17	9-17
ESC B	66	42	Set Vertical Tabs	9-18	9-18
ESC b	98	62	Set Vertical Tabs in Channels	9-18	
ESC I	47	2F	Select Vertical Tab Channel	9-19	

Horizontal motion

ASCII	Dec	Hex	Description	ESC/P page	IBM page
ESC I	108	6C	Set Left Margin	9-19	
ESC Q	81	51	Set Right Margin	9-20	
ESC X	88	58	Set Left and Right Margins		9-46
BS	8	08	Backspace	9-20	9-20
ESC \$	36	24	Set Absolute Print Position	9-21	
ESC \	92	5C	Set Relative Print Position	9-21	
HT	9	09	Tab Horizontally	9-22	9-22
ESC D	68	44	Set Horizontal Tabs	9-22	9-45
ESC R	82	52	Restore Default Tab Settings		9-45

Overall printing style

ASCII	Dec	Hex	Description	ESC/P Page	IBM page
ESC x	120	78	Select Letter Quality or Draft	9-23	
ESC k	107	6B	Select Typestyle Family	9-23	
ESC I	33	21	Master Select	9-24	
ESC I	73	49	Select Font		9-46

Print size and character width

ASCII	Dec	Hex	Description	ESC/P page	IBM page
ESC P	80	50	Select 10 cpi	9-25	
ESC M	77	4D	Select 12 cpi	9-25	
DC 2	18	12	Select 10 cpi		9-47
ESC :	58	3A	Select 12 cpi		9-47
ESC p	112	70	Turn Proportional Mode On/Off	9-25	
ESC P	80	50	Turn Proportional Mode On/Off		9-47
SI	15	0F	Select Condensed Mode	9-26	9-26
ESC SI	15	0F	Select Condensed Mode	9-26	9-26
DC2	18	12	Cancel Condensed Mode	9-26	
SO	14	0E	Select Double-wide Mode (one line)	9-27	9-27
ESC SO	14	0E	Select Double-wide Mode (one line)	9-27	9-27
DC4	20	14	Cancel Double-wide Mode (one line)	9-27	9-27
ESC W	87	57	Turn Double-wide Mode On/Off	9-28	9-28
ESC w	119	77	Turn Double-high Mode On/Off	9-28	
ESC [@	91	5B	Set Double-high/Double-wide Printing		9-48

Print enhancement

ASCII	Dec	Hex	Description	ESC/P page	IBM page
ESC E	69	45	Select Emphasized Mode	9-29	9-29
ESC F	70	46	Cancel Emphasized Mode	9-29	9-29
ESC G	71	47	Select Double-strike Mode	9-30	9-30
ESC H	72	48	Cancel Double-strike Mode	9-30	9-30
ESC S0	83	53	Select Superscript Mode	9-30	9-30
ESC S1	83	53	Select Subscript Mode	9-31	9-31
ESC T	84	54	Cancel Superscript/Subscript Mode	9-31	9-31
ESC 4	52	34	Select Italic Mode	9-31	
ESC 5	53	35	Cancel Italic Mode	9-32	
ESC -	45	2D	Turn Underline Mode On/Off	9-32	9-32
ESC _	95	5F	Turn Overscoring Mode On/Off		9-48

Word processing

ASCII	Dec	Hex	Description	ESC/P page	IBM page
ESC a	97	61	Select Justification	9-33	
ESC SP	32	20	Set Intercharacter Space	9-33	

Character tables

ASCII	Dec	Hex	Description	ESC/P page	IBM page
ESC t	116	74	Select Character Tables	9-34	
ESC R	82	52	Select an International Character Set	9-34	
ESC 6	54	36	Enable Printable Characters	9-35	
ESC 7	55	37	Enable Upper Control Codes	9-35	
ESC 6	54	36	Select International Character Set		9-49
ESC 7	55	37	Select Standard Character Set		9-49
ESC \	92	5C	Print Character from Symbol Set		9-49
ESC ^	94	5E	Print One Character from Symbol Set		9-50

User-defined characters

ASCII	Dec	Hex	Description	ESC/P page	IBM page
ESC &	38	26	Define User-defined Characters	9-36	
ESC :	58	3A	Copy ROM to RAM	9-36	
ESC %	37	25	Select User-defined Set	9-37	
ESC I	73	49	Printable Code Area Expansion	9-37	
ESC =	61	3D	Define User-defined Character		9-50

Graphics

ASCII	Dec	Hex	Description	ESC/P page	IBM page
ESC K	75	4B	Select Single-density Graphics Mode	9-38	9-38
ESC L	76	4C	Select Double-density Graphics Mode	9-38	9-38
ESC Y	89	59	Select High-speed Double-density	9-38	9-38
ESC Z	90	5A	Select Quadruple-density Graphics Mode	9-39	9-39
ESC *	42	2A	Select Graphics Mode	9-39	
ESC ?	63	3F	Reassign Graphics Mode	9-40	
ESC ^	94	5E	Select 9-pin Graphics Mode	9-40	

DIP Switch Settings

DIP switch 1

SW	Description	ON	OFF
1-1	Condensed mode on/off	Condensed	Normal
1-2	Slashed zero on/off	Slashed	Not slashed
1-3	Character table (in Epson ESC/P mode)	Graphics	Italics
1-4	Printer mode	IBM emulation	Epson ESC/P
1-5	NLQ or draft mode	NLQ	Draft
1-6	International character set (available only in Epson ESC/P mode)	See table to the right.	
1-7			
1-8			

DIP switch 2

SW	Description	ON	OFF
2-1	Default character set (in Epson ESC/P mode)	User-defined	ROM
2-2	Draft printing speed	Normal	High
2-3	Bit length for serial interface	7 bits	8 bits
2-4	Auto line feed	ON	OFF
2-5	Interface type/parity	See table to the right.	
2-6			
2-7	Baud rate	See table to the right.	
2-8			

DIP switch 3

SW	Description	ON	OFF
3-1	Input buffer	Invalid	Valid
3-2	Page length	12 inches	11 inches
3-3	1-inch skip over perforation	ON	OFF
3-4	Paper memory	Memory 2	Memory 1
3-5	Overlapping multi-part forms	Valid	Invalid
3-6	Multi-part forms with labels	Valid	Invalid
3-7	Skip over binding	ON	OFF
3-8	Handshaking protocol	X-on/X-off	DTR

International character set

Country	SW 1-6	SW 1-7	SW 1-8
USA	ON	ON	ON
France	ON	ON	OFF
Germany	ON	OFF	ON
United Kingdom	ON	OFF	OFF
Denmark	OFF	ON	ON
Sweden	OFF	ON	OFF
Italy	OFF	OFF	ON
Spain	OFF	OFF	OFF

Interface/Parity selection

Interface/Parity	SW 2-5	SW 2-6
Parallel	OFF	OFF
Serial/odd	OFF	ON
Serial/even	ON	OFF
Serial/none	ON	ON

Baud rate selection

Baud rate	SW 2-7	SW 2-8
19200 bps	OFF	OFF
9600 bps	OFF	ON
1200 bps	ON	OFF
300 bps	ON	ON

DIP switch functions in IBM emulation mode (DIP switch 1-4 on)

SW	Description	ON	OFF
1-3	Automatic carriage return	ON	OFF
1-6	Default character table	See table below.	
1-7			
1-8			
2-1	FF command at the top of form position	Invalid	V a l i d

IBM emulation mode character tables

Default character table	SW 1-6	SW 1-7	SW 1-8
Table 1 (standard)	ON	ON	ON
Table 2 (international)	Table 2 is selected when any one of these switches is turned off.		

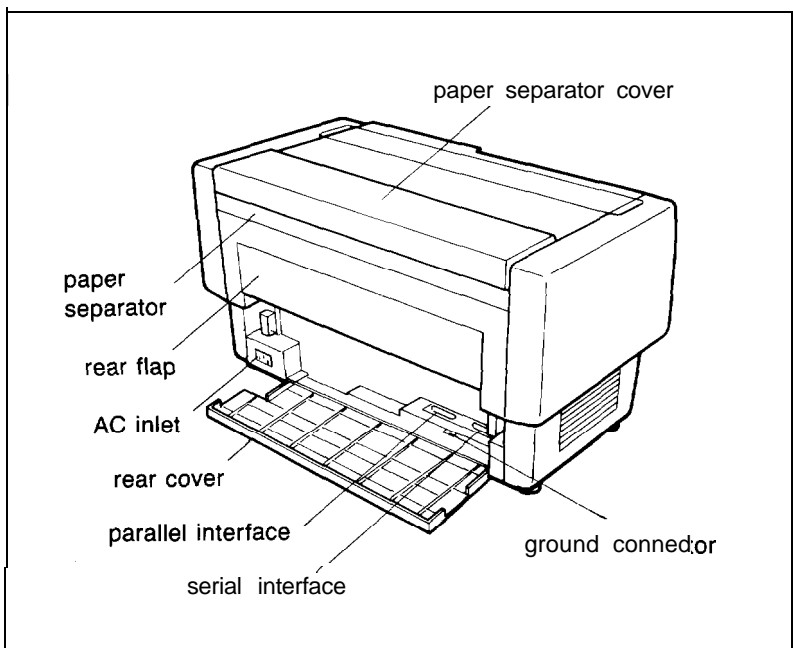
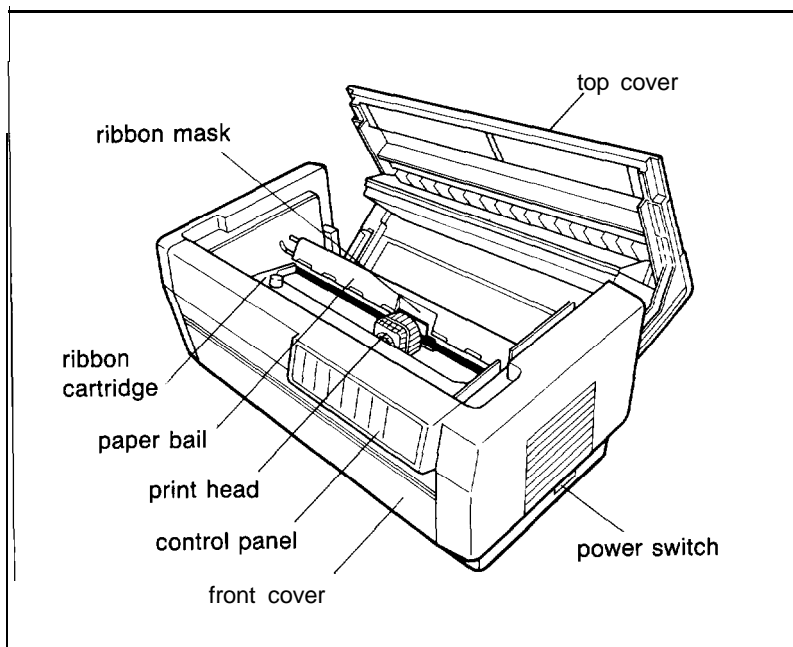

User's Manual

DFX-8000

EPSON®

DFX-8000

EPSON AMERICA, INC. 2780 Lomita Boulevard, Torrance, California 90505

EPSON®

Printed in Japan 91.04-1.1