

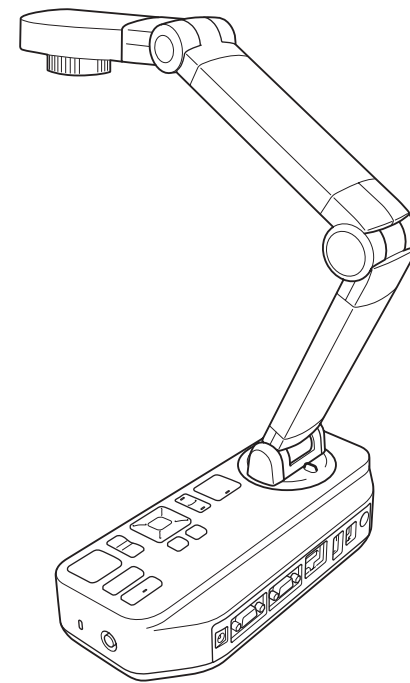

EPSON
EXCEED YOUR VISION

ELPDC12
Document Camera
User's Guide



Important Safety Instructions

Read this *User's Guide* and follow all safety instructions for your document camera. Keep this guide at hand for future reference.

 Warning	This symbol indicates information that, if ignored, could possibly result in personal injury or even death due to incorrect handling.
 Caution	This symbol indicates information that, if ignored, could possibly result in personal injury or physical damage due to incorrect handling.

Environmental Precautions

Warning

Do not leave the document camera or the remote control with batteries inside a vehicle with the windows closed, in places where they will be exposed to direct sunlight, or in other places that may become extremely hot. Thermal damage, fire, or malfunction may occur.

Do not use or store the document camera outdoors for an extended length of time, or where it may be exposed to rain, water, or excessive humidity. Fire or electric shock may result.

Do not use the document camera in places where smoke from cigarettes may be present, where it will be exposed to greasy smoke, humidity, or steam (such as cooking areas or near humidifiers), or where there is a lot of heat or dust. This can adversely affect the quality of the projected images.

Caution

Do not set up the document camera near high-voltage electrical wires or sources of magnetic fields. This may interfere with correct operation.

Operate in the proper environmental conditions.  [p.80](#)

Do not place or store the unit where it is accessible to small children. The unit may drop or tip over, causing personal injury.

Do not place the document camera where it will be subject to a lot of vibration or shock.

Electrical Precautions

Warning

Never open any covers on the document camera except as specifically explained in this *User's Guide*. Never attempt to disassemble or modify the document camera. Refer all repairs to qualified service technicians.

Unplug the document camera from the outlet and refer all repairs to qualified service technicians under the following conditions:

- If smoke, strange odors, or strange noises come from the device
- If liquid or foreign objects get inside the device
- If the device has been dropped or the housing has been damaged

Continuing to use under these conditions may result in fire or electric shock.

Do not attempt to use any adapter other than the AC adapter and power cord included with the device. Using an improper adapter may cause damage, overheating, fire, or electric shock.

Be sure to use the AC adapter with the proper voltage indicated in this guide. Use of a different power source may result in fire or electric shock.

If the AC adapter, power cord, or document camera is damaged, turn the power off, unplug the AC adapter from the electrical outlet, and contact your local distributor. Using the damaged device may cause fire or electric shock.

Do not touch the device, the AC adapter, or the plug with wet hands. This may cause electric shock.

Do not use the power cable that is damaged. Fire or electric shock may result.

- Do not modify the power cable.
- Do not place heavy objects on top of the power cable.
- Do not bend, twist or pull the power cable excessively.
- Keep the power cable away from hot electrical appliances.

Take the following precautions when handling the plug. Failure to comply with these precautions could result in fire or electric shock.

- Do not overload wall outlets, extension cables, or power strips.
- Do not insert the plug into a dusty outlet.
- Insert the plug firmly into the outlet.
- Do not pull the power cable when disconnecting the plug; always be sure to hold the plug when disconnecting it.

Do not touch the plug during an electrical storm. Otherwise, you may receive an electric shock.

Caution

Turn off the document camera and unplug it after use.

Make sure the power is turned off, the plug is disconnected from the outlet, and all cables are disconnected before moving the document camera.

Installation Precautions

Warning

If you apply adhesives to prevent the screws from loosening, or if you use lubricants or oils on the document camera, the document camera housing may crack. This could cause serious injury. Do not use adhesives to prevent the screws from loosening and do not use oils or lubricants.

Caution

Do not place the document camera in an unstable location, such as on a shaky table or slanted surface. The document camera may drop or tip over, causing personal injury. If you use a table, cart, or stand, make sure it is stable and will not fall over.

When using the mounting points under the document camera to secure it to a table, cart, or stand, fasten the bolts securely but do not overtighten them. Do not use adhesives.

Do not place the document camera in a poorly ventilated place where heat can accumulate.

Do not place the document camera on a carpet, blanket, etc. or cover it during use.

Cleaning Precautions

Warning

Use a dry cloth (or, for stubborn stains, a moist cloth that has been wrung dry) for cleaning. Do not use liquid, aerosol cleaners, or solvents such as alcohol, thinner or benzene.

Do not place any containers of liquid on top of or near the unit.

Do not spill liquid or spray fine mist into the document camera. Liquids entering the document camera may cause malfunction, fire, or electric shock. If you spilled liquid, turn the power off, unplug the AC adapter from the electrical outlet, and contact your local distributor. Using the damaged device may cause fire or electric shock.

Do not insert or drop metal, flammable, or foreign objects into the document camera's vents or openings nor leave them nearby. Doing so may result in fire, electric shock, or burns.

Caution

Unplug the AC adapter from the outlet before cleaning to prevent electric shock.

Usage Precautions

Caution

Do not look into the lens when the LED illumination lamp is on. The bright light can damage your eyes.

Do not use excessive force when adjusting the document camera. The document camera may be broken, resulting in personal injury.

Do not place heavy objects on document camera, or it may be damaged.

Do not try to press the arm flat or fold it backwards, or it may get damaged.

Battery Precautions

Warning

Incorrect battery usage may cause batteries to rupture and leak battery fluid, which could result in fire, injury, or corrosion of the remote control.

If liquid from a battery gets in your eyes, do not rub your eyes. Wash them well with clean water and contact a doctor immediately. If liquid enters your mouth, rinse immediately with plenty of water and consult a doctor. If liquid from the battery comes in contact with your skin or clothes, wash with water to prevent possible skin damage.

Keep batteries out of the reach of children. Batteries are a choking hazard and are very dangerous if swallowed.

Prepare two replacement manganese or alkaline AA batteries. Do not use any other kinds of batteries.

Insert batteries so that the polarities (+ and -) are correct. Not doing so may cause leakage, overheating, or explosion.

Do not use a new battery and an old battery, or different types of batteries at the same time. Doing so may cause leakage, overheating, or explosion.

Remove the batteries if you will not be using the remote control for a long period of time. When a battery runs down, take it out of the remote control immediately. If a discharged battery is left inside for a long time, gas emitted from the battery may cause leakage, overheating, explosion, or damage to the remote control.

Do not heat batteries or put them into fire or water.

When you throw away the batteries, follow your area's regulations regarding disposal or recycling.



Memory Card Precautions



Caution

We recommend backing up data on the document camera's internal memory, your USB drive, or SD card to another media. Data may be lost or damaged under the following conditions.

- If the power cable is disconnected from the document camera while recording or exporting data
- If the SD card or USB drive is removed from the document camera while recording or exporting data
- If it is subjected to static electricity or electrical noise
- If it is used incorrectly
- If a malfunction occurs or if the device needs to be repaired
- If damage occurs due to a natural disaster

In addition to the situations mentioned above, Epson shall not be responsible for the loss of any data or damage to data even during a warranty period.



Important Safety Instructions 2

Introduction

Product Features 10

Included Items 10

Document Camera Parts 11

Top/Side/Rear 11

Camera Head 12

Control Panel 12

Interface 13

Base 14

Remote Control Buttons 15

Remote Control 15

Projector operations 15

Document camera operation 15

Storing the Document Camera 17

Securing the Document Camera 18

Connecting

Connecting to a Projector 20

Connecting to a Computer 22

Connect for Use with the Document Camera Software 22

Connect for Use Without the Document Camera Software 23

Projecting

Plugging In and Turning On 25

Displaying a Document or Other Materials 26

Positioning the Document Camera 26

Projecting 27

Freezing an Image 29

Displaying Small Objects Up Close 29

Displaying Live Action or Whiteboard Images 30

Projecting Through a Microscope 31

Adding Annotations 33

Switching Between Your Computer and the Live Camera Image

..... 35

Displaying a Split Screen 36

Saving Images and Displaying a Slideshow

Saving Images 39

Recording Movies 40

Connecting an External Microphone 40

Exporting and Importing Images 42

Viewing and Managing Files from Your Computer 44

Displaying a Slideshow 45



Image Adjustments and Effects

Using the On-screen Menu	48
On-screen Menu List	49
Image Menu	49
Function Menu	50
Memory Menu	52
Info Menu	53

Using the Included Software

Installing the Software	55
Uninstalling the Software	55
Windows 8	55
Windows 7/Windows Vista/Windows XP	55
Mac OS X	55
Starting the Software	56
Annotating Images	57
Capturing Still Images	58
Making Time-lapse Movies	59
Recording Videos	60
Compatible File Format	60
Editing Saved Files	62
Managing Saved Files	63
Uploading and Sharing Your Videos	64

Solving Problems

Problems and Solutions	66
Operation Problems	66
Image Quality Problems	66
Problems Using an SD Card	67
Problems Using a USB Drive	67
Problems Connecting a Laptop	67
Problems Using the Document Camera Software	67
Where to Get Help	69
Europe, Middle East & Africa	69
North and Central America	75
South America	75
Asia and Oceania	76

Notices

Specifications	80
General Specifications	80
System Requirements	82
FCC Compliance Statement	83
For United States Users	83
WARNING	83
For Canadian Users	83
Declaration of Conformity	84
Copyrights and Trademarks	85
Responsible Use of Copyrighted Materials	85
Trademarks	85



Introduction

You can use the Epson ELPDC12 document camera to capture and project pages from books or other documents, and even three-dimensional objects. With the included software, you can create time-lapse photos and annotate images produced by the document camera.

Included Items

- Remote control with 2 AA batteries
- Power cord and adapter
- VGA cable
- USB cable
- Software CD
- User's manual CD
- *Quick Start*
- Microscope adapter

Top/Side/Rear

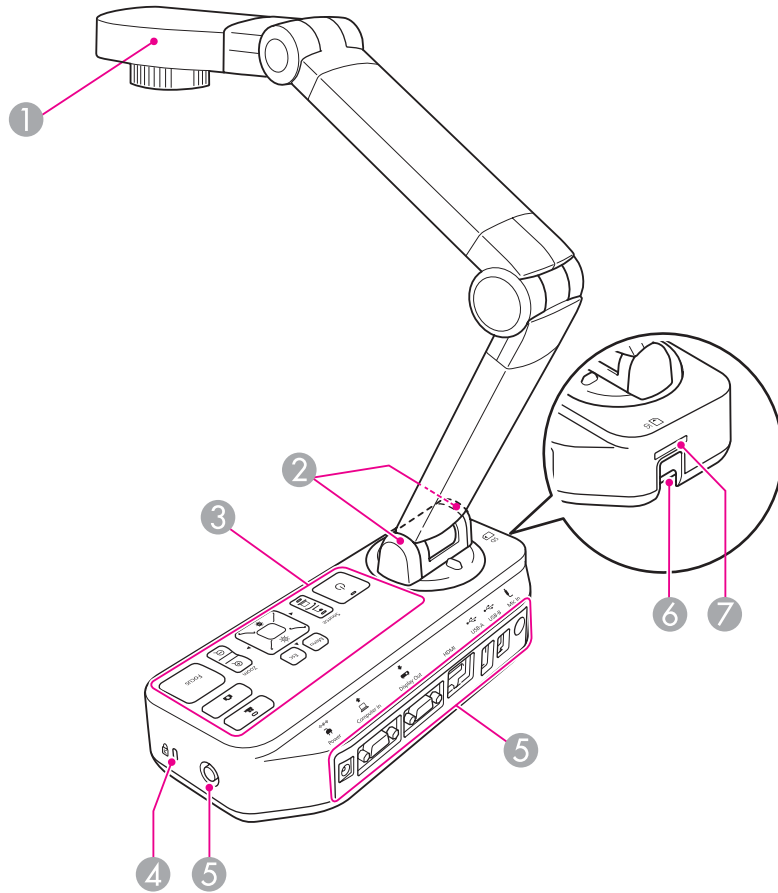

Name	Function
① Camera head	☛ "Camera Head" p.12
② Remote receiver	Receives signals from the remote control.
③ Control panel	☛ "Control Panel" p.12

Name	Function
④ Security slot	The security slot is compatible with the Microsaver security system manufactured by Kensington. ☛ p.18
⑤ Interface	☛ "Interface" p.13
⑥ Security bar	Lets you attach a commercially available security cable to lock the document camera in place. ☛ p.18
⑦ SD card slot	Lets you save and display images on an SD card. ☛ p.38

Camera Head

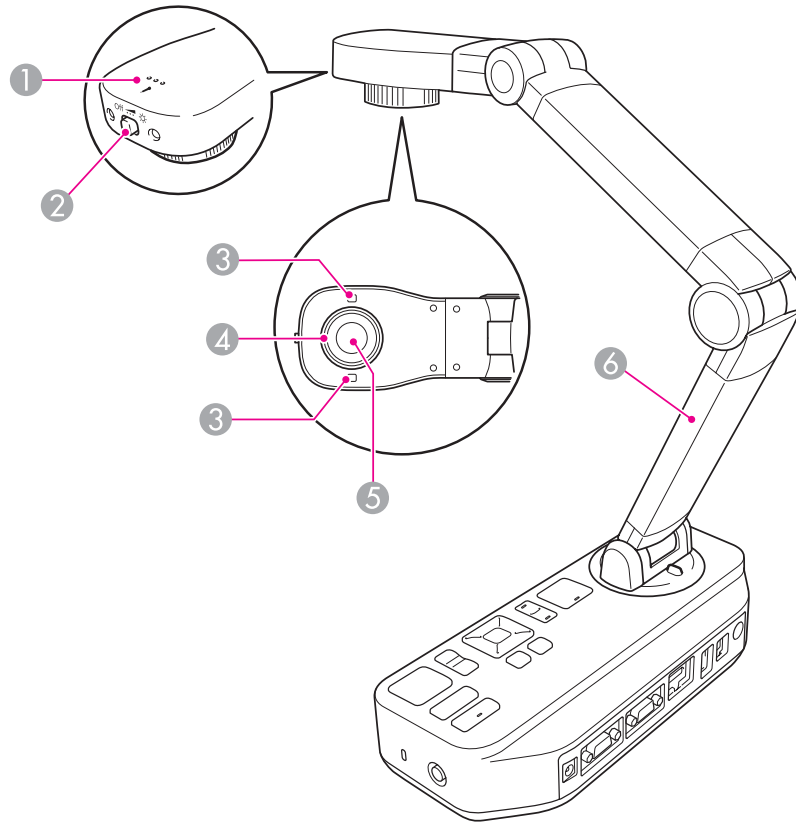

Name	Function
① Microphone	Captures sound when you record a video.
② [-☀-] Lamp switch	Changes the LED lamp status in three steps: bright, dim, and off.
③ LED lamp	Turn on this lamp when there is not enough light on your document.
④ Image rotation dial	Turns the displayed image $\pm 90^\circ$.
⑤ Camera lens	Captures the image.

Name	Function
⑥ Camera arm	Extends or retracts the camera arm to adjust the height of the camera head.

Attention

Do not rub the lens with harsh materials or subject it to shock, as it can be easily damaged. Use a soft cloth to gently wipe the lens.

Control Panel

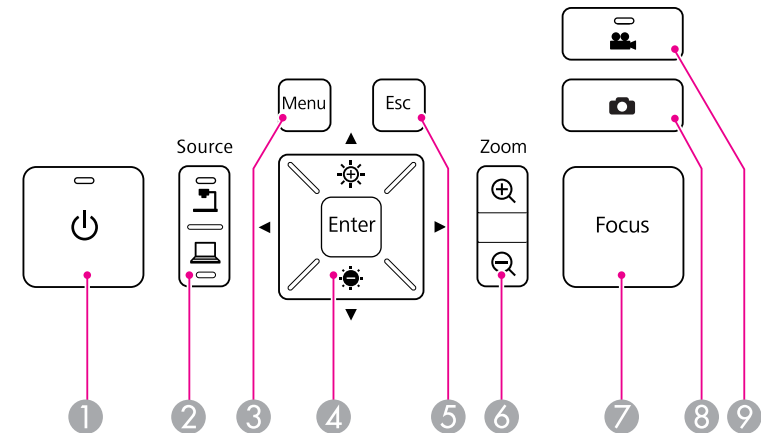

Name	Function
① [⏻] button	Turns the document camera power on or off.
② [Source] button [📷] [💻]	[📷] Projects images from the document camera. [💻] Projects images from a computer.
③ [Menu] button	Opens and closes the menu.

Name	Function
4	[▲][▼][◀][▶] button When the menu screen is displayed, pressing these buttons selects menu items and setting values.
	[☀️][🌑] button Adjusts the image Brightness.
	[Enter] button When the menu is displayed, pressing this button confirms the current item.
5	[Esc] button Stops the current function. When the menu is displayed, pressing this button moves to the previous menu level.
6	[Zoom] button [⊕][⊖] Enlarges or reduces the image without changing the projection size. p.27
7	[Focus] button Press the [Focus] button to automatically focus the image. The unit cannot focus on objects that are approximately 10 cm (4 inches) or less from the surface of the camera lens.
8	[📷] button If you press and release the button, the image is frozen. If you press and hold the button, the still image is saved. p.39
9	[👤] button Starts and stops video recording.

Interface

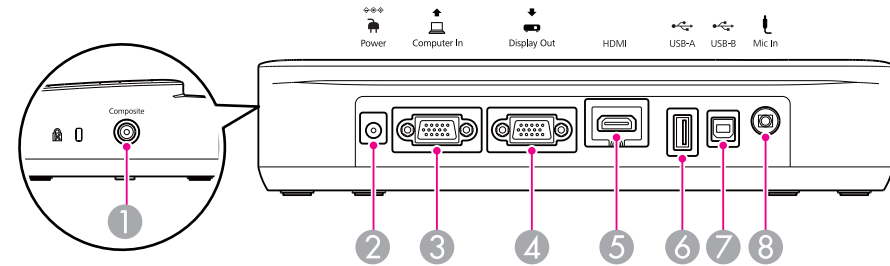

Name	Function
1 Composite port	Outputs composite video signals to a projector or external monitor.
2 Power (AC adapter) port	Connects the supplied power cord and adapter.
3 Computer In port	Inputs image signals from a computer.
4 Display Out port	Outputs image signals to a projector.
5 HDMI port	Outputs image signals to a video device or computer that is compatible with HDMI signal.
6 USB-A (TypeA) port	Lets you annotate live images by connecting a commercially available USB mouse. p.33 Lets you save and display images on a USB drive.
7 USB-B (TypeB) port	Connects the document camera to a computer via the supplied USB cable when using the included software.
8 Mic In port	Connects a commercially available microphone when recording audio and video.

Base

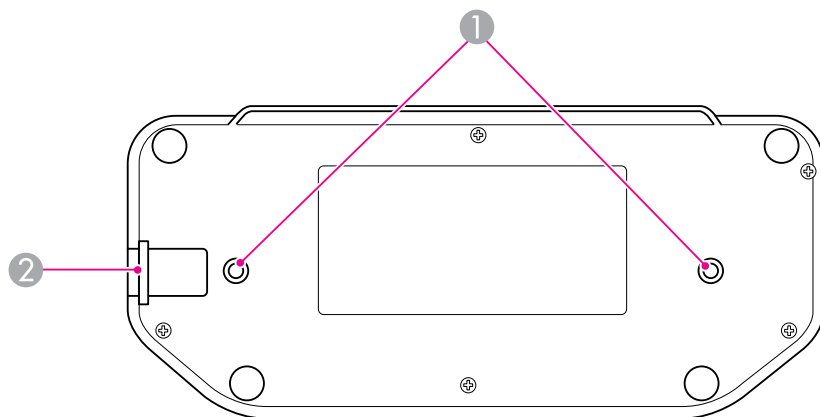

	Name	Function
①	Mounting points	You can attach the document camera to a table, cart, or stand with commercially available M4 bolts. 👉 p.18
②	Security bar	Lets you attach a commercially available security cable to lock the document camera in place. 👉 p.18

Remote Control

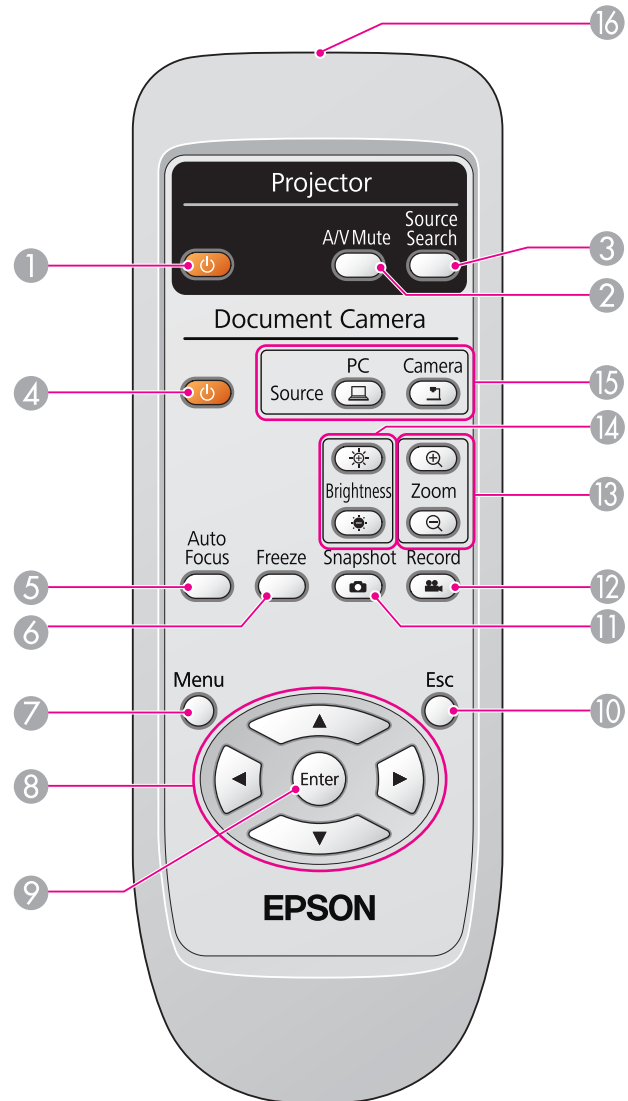

Projector operations







	Name	Function
①	[⏻] button	When used with an Epson projector, turns the projector on or off.* You cannot operate the document camera with this button.
②	[A/V Mute] button	Turns the video and audio of an Epson projector on or off.*
③	[Source Search] button	Changes the input source connected to an Epson projector.*

* This is not supported by some projectors. For more details, contact your local dealer or the nearest service center provided in this guide.

☞ "Where to Get Help" p.69

Document camera operation

	Name	Function
④	[⏻] button	Turns the document camera on or off. You cannot operate a projector with this button.
⑤	[Auto Focus] button	Press the [Auto Focus] button to automatically focus the image. The unit cannot focus on objects that are approximately 10 cm (4 inches) or less from the surface of the camera lens.
⑥	[Freeze] button	Freezes the current image; press the button again to continue.
⑦	[Menu] button	Displays and closes the menu.
⑧	[▲] [▼] [◀] [▶] buttons	When the menu or Help screen is displayed, pressing these buttons selects menu items and setting values.
⑨	[Enter] button	When the menu is displayed, pressing this button confirms the current item.

	Name	Function
⑩	[Esc] button	Stops the current function. When the menu is displayed, pressing this button moves to the previous menu level.
⑪	[Snapshot] button 	Captures still images.
⑫	[Record] button 	Starts and stops video recording.
⑬	[Zoom] button [+] [-]	Enlarges or reduces the image without changing the projection size.  p.27
⑭	[Brightness] button [-] [+]	Adjusts the image brightness.
⑮	[Source] button  	 Projects images from a computer.  Projects images from the document camera.
⑯	Remote control light emitting area	Outputs remote control signals.

When you're not using the document camera, simply fold its arm down as shown.

 **Caution**

Do not try to press the arm flat or fold it backwards, or it may get damaged.

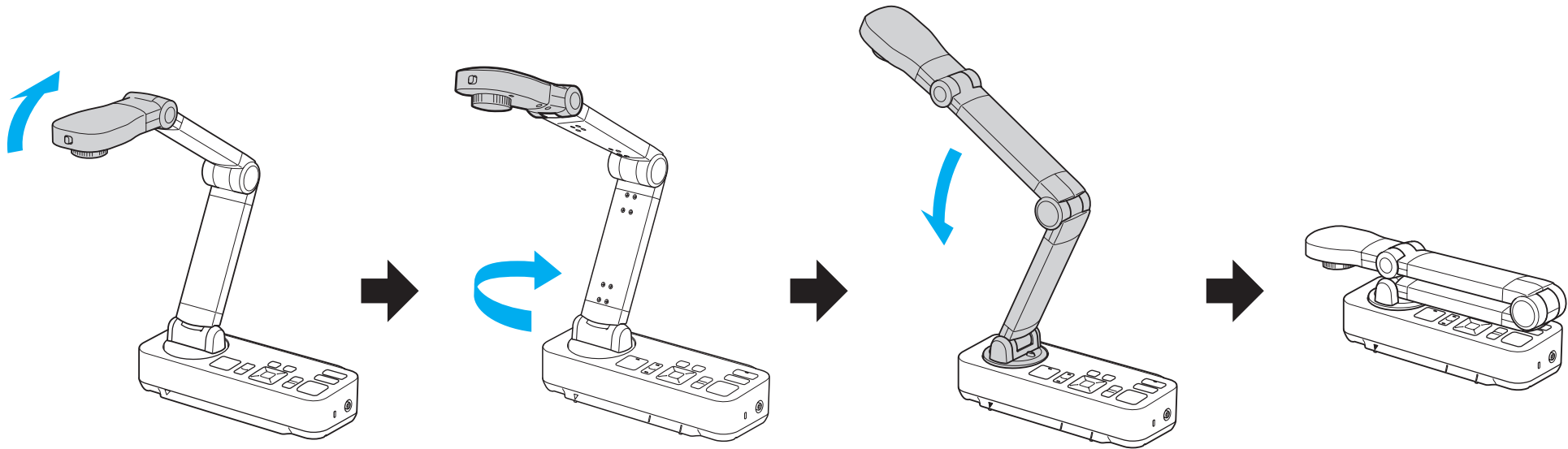

You can secure the document camera by fastening a cable to the security bar, shown below, or by inserting a Kensington anti-theft cable into the Kensington security port.

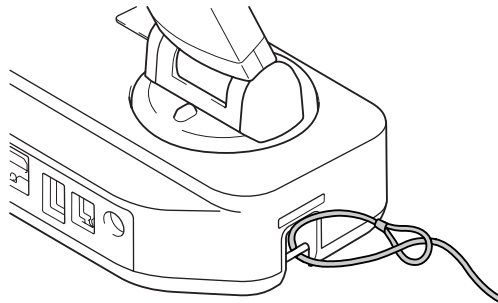

In addition, you can attach the document camera to a table, cart, or stand at the mounting points indicated below. Use M4 bolts; you can thread them into the document camera case to a maximum depth of 9 mm (0.35 inch).

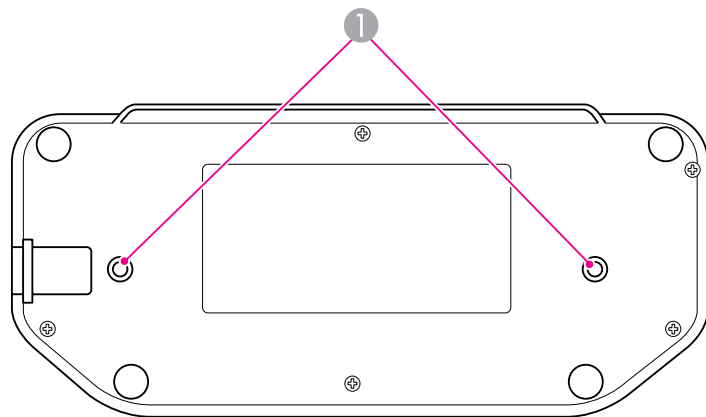

1 Mounting points

Attention

Fasten the bolts securely but do not overtighten them. Do not use adhesives.



Connecting

Follow the instructions in this section to set up the document camera and give a presentation.

You can connect the document camera to a projector using a standard VGA cable, composite video cable, or HDMI cable, or to other video equipment such as an external monitor.

 You can also use the document camera with a computer. [p.22](#)

1 Choose the type of cable you will use, based on the type of port that's available on your projector or other video equipment:

VGA port
(computer monitor style)

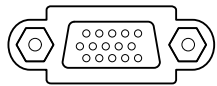

VGA cable (included)

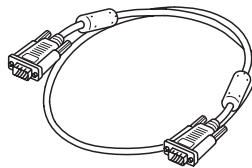

Composite video port
(yellow "RCA" style)



Composite video cable

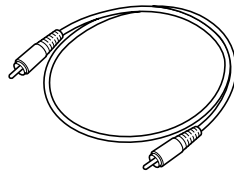

HDMI port

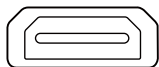

HDMI cable

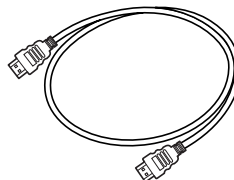

2 Connect the document camera by one of the following methods:
VGA connection

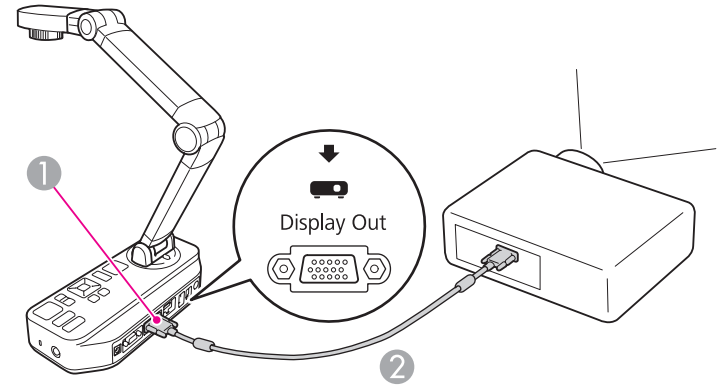

- 1 Display Out port
- 2 VGA cable

Composite video connection

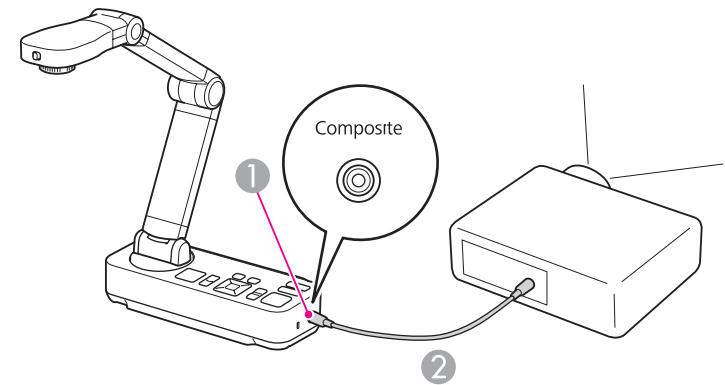

- 1 Composite port

② Composite video cable

HDMI connection

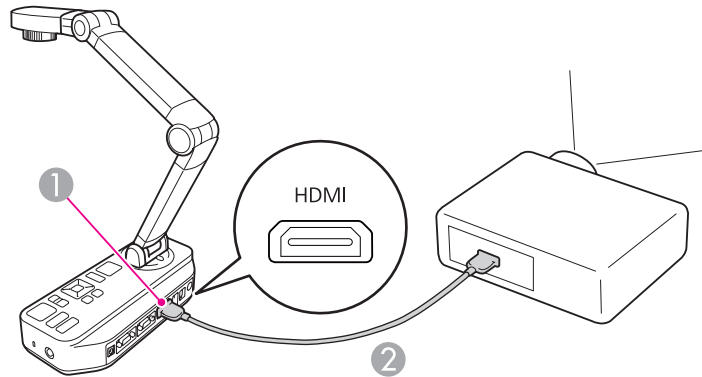

① HDMI port

② HDMI cable



- When connecting with a USB cable, video from other output ports is not displayed.
- When two or more cables are connected, the priority of video output is **HDMI > Display Out > Composite**.

When you connect the document camera to your computer, you can use the included software to capture, edit, and play back still images and videos.

☛ p.54

Connecting to a computer also lets you display PowerPoint slides or other applications. You can easily switch back to the live camera image at any time.

How you connect to your computer depends on the software you plan to use:

- To use the included software, see "Connect for Use with the Document Camera Software" p.22 below.
- If you don't plan to use the software or it's not installed on your computer, see "Connect for Use Without the Document Camera Software" p.23.

Connect for Use with the Document Camera Software

This connection method lets you use the included software, as well as display PowerPoint slides or images from another application on your computer. Make sure you've already installed the software. ☛ p.55

- 1** Connect the document camera to your computer with a USB cable, as shown.

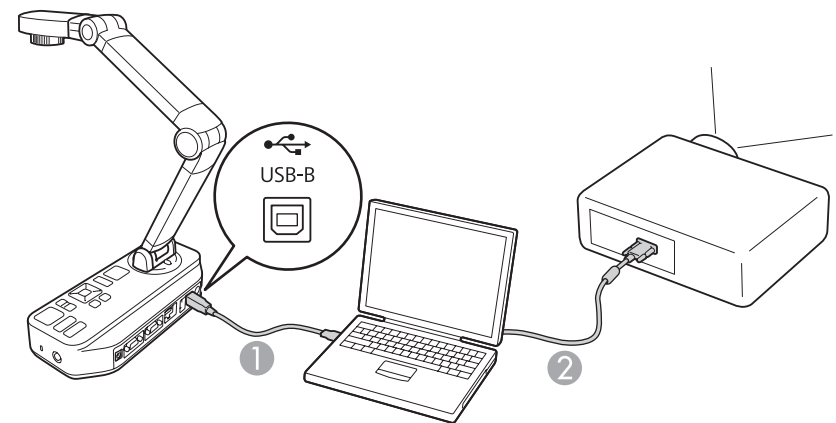

- 1** USB cable
- 2** VGA cable



- When connecting with a USB cable, video from other output ports is not displayed.
- You cannot display images by directly connecting the document camera to a projector with a USB cable.
- Connect the document camera to a USB 2.0 port of a computer. If you connect it to a USB 3.0 port, it may not function normally.

2

Connect your computer to your projector using a VGA cable.



- It's also possible to connect with composite video, but most computers lack this type of port.

3

Follow the instructions on p.56 to use the document camera software.



If an image doesn't appear on the screen, the document camera's **USB Mode** may be set to **Mass Storage**; see [p.67](#) to change the setting. If you connected a laptop, see [p.67](#) to check your laptop settings.

Connect for Use Without the Document Camera Software

This connection method lets you display PowerPoint slides or images from another application on your computer, but you can't use the included software.

- 1** If you're using a desktop computer, disconnect the monitor from your computer.
- 2** Connect a VGA cable from your computer's monitor-out port to the document camera's **Computer In** port.

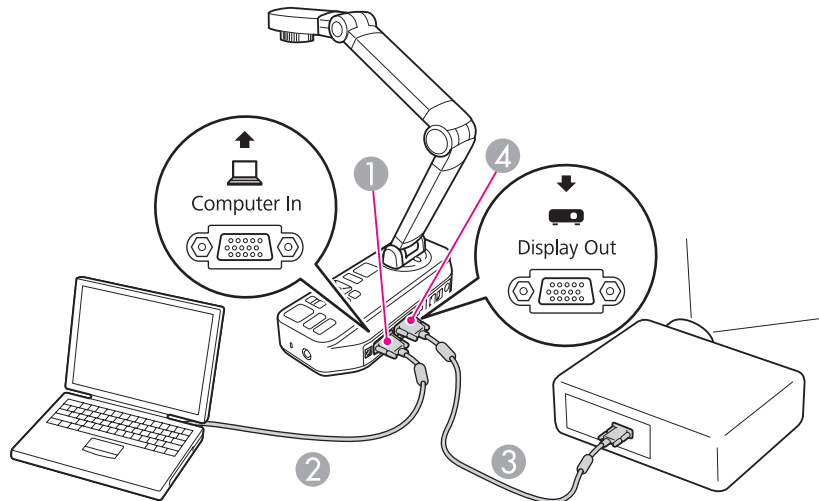

1 Computer In port

- 2** VGA cable
- 3** VGA cable
- 4** Display Out port

- 3** Connect a second VGA cable from the document camera's **Display Out** port to your projector.



- If you connected a laptop but the image doesn't appear on the screen, check your laptop settings. [p.67](#)
- A video signal from the **Computer In** port can only be output from a **Display Out** port.



Projecting

- 1 Connect the power adapter as shown and plug the adapter into a wall outlet.

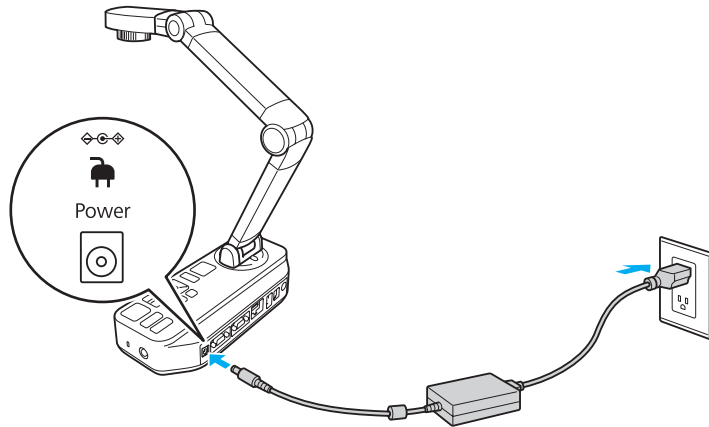

- 2 Press the [⏻] power button to turn on the document camera. It takes about 20 seconds for the document camera to output an image.
- 3 Turn on your projector.
- 4 Select the appropriate "source" on the projector depending on the port to which you connected.



When you're done using the document camera, press the [⏻] power button twice to turn it off, disconnect any cables, and fold down the camera arm. [p.17](#)

Positioning the Document Camera

- 1** Raise the camera arm while holding the body with your other hand.

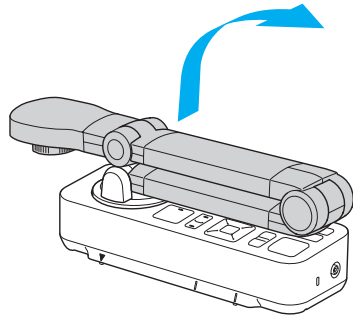

- 2** Rotate the camera arm as shown below.

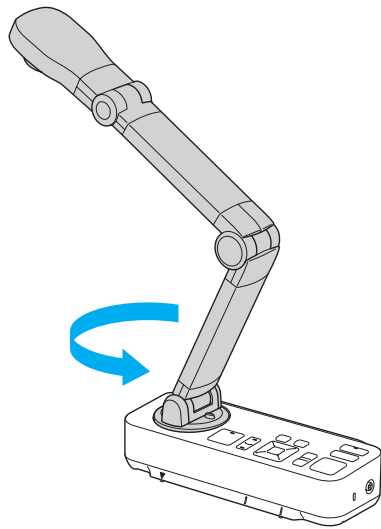

- 3** Position the camera head above the display area.

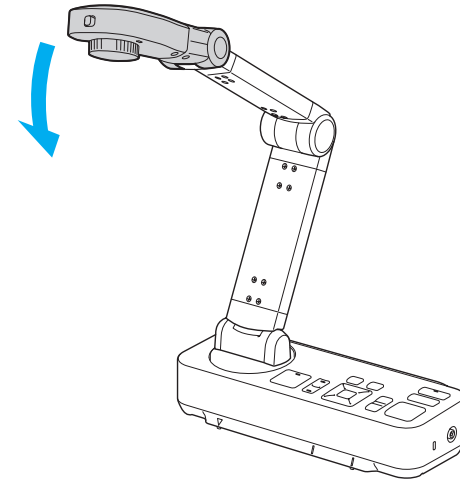

Attention

Do not try to press the arm flat or fold it backwards, or it may get damaged.

The camera arm can only rotate within the range shown below.

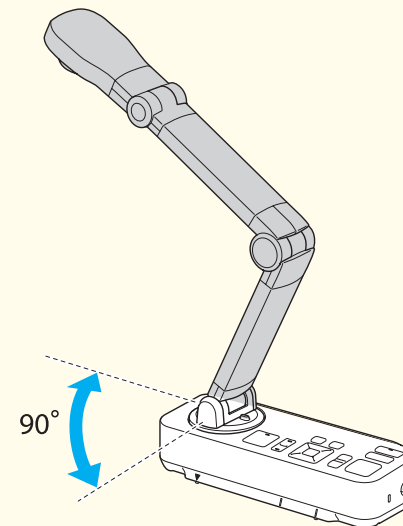

Projecting

- 1 Place your document on the table under the camera head. Align the center of your document with the ▽ mark on the side of the document camera.



- You can quickly align letter- or A4-size paper with the guides on the side of the document camera.
- The maximum paper size that can be projected is A3 landscape.

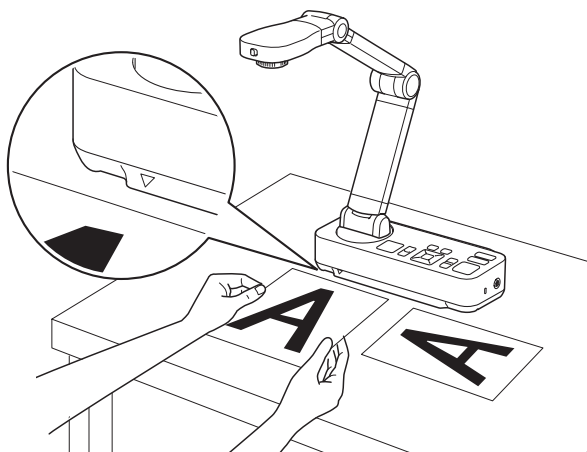

- 2 Slide the lamp switch to illuminate the document.



If necessary, you can adjust the brightness of the image using the [☀] or [☿] on the document camera or remote control.

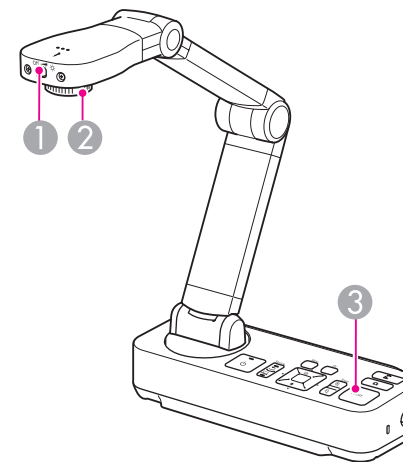

- 1 Lamp switch
- 2 Image rotation dial
- 3 [Focus] button

- 3 Turn the dial on the camera head to rotate the image on the screen.



If desired, you can rotate an upside-down image by pressing the [Menu] button and select **Image > Image Rotation > 180 degrees**.

- 4 Press the [Focus] button on the document camera or the [Auto Focus] button on the remote control. Your document is automatically focused.



To sharpen hard-to-focus objects, press the [Menu] button and select **Image > Focus**. Use the [◀] and [▶] arrow buttons to adjust the focus.

- 5** To zoom in on part of the image, press the [Zoom] - [⊕] button on the document camera or remote control. Press the [Zoom] - [⊖] button to zoom out.



- You can zoom up to 16x. When using the digital zoom, you can scroll the enlarged image by pressing the [▲], [▼], [◀], and [▶] arrow buttons.
- When the **Zoom Area Window** function is **On**, the entire image is displayed at the bottom-right of the screen with a box that indicates the enlarged part when you increase the zoom ratio more than twice. When it is **Off**, a box is displayed that indicates the enlargement ratio. To enable the Zoom Area Window function, press the [Menu] button and select **Image > Zoom Area Window**.

When Zoom Area Window is On:



When Zoom Area Window is Off:



- Depending on the output resolution of the projector or external monitor, part of the area shown in the box at the bottom-right of the screen may not be enlarged.
- Image quality may decrease when the image is enlarged.

Freezing an Image

Press and release the [📷] button to freeze the image. (If you press and hold the button, it saves the image. 🖱️ p.39)

After freezing the image, you can remove your document while leaving its image displayed on the screen. Place your next document under the camera lens and press the button again; your presentation continues without interruption.



You cannot enlarge the image while the image is frozen.

Displaying Small Objects Up Close

To display a small object, lower the camera arm. You can place the lens within approximately 10 cm (4 inches) of the object.

To further enlarge an object, press the [Zoom] - [⊕] button on the document camera or remote control. Press the [Zoom] - [⊖] button to zoom out.

You can use the document camera to display a lecture or presentation at the front of a room, or to capture images of a whiteboard or chalkboard.



Press the [Menu] button and select **Image > Image Rotation to 180 degrees** to display the image upside-down.

- 1** Raise and rotate the camera head to face the front of the room.

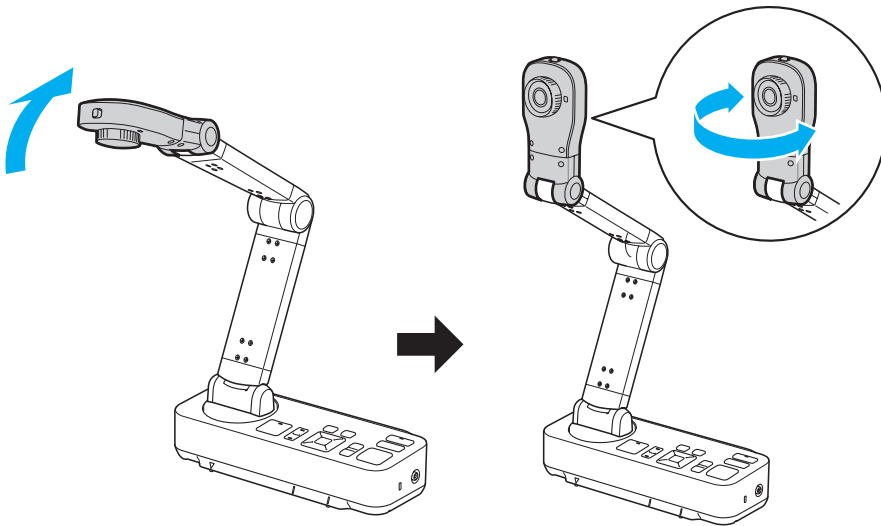

- 2** Press the [Focus] button on the document camera or the [Auto Focus] button on the remote control. The image is automatically focused.



You can make an audio/video recording of the live presentation in the document camera's 1GB internal memory, on an inserted SD card, or with a connected USB drive or computer.

 [p.40](#), [p.60](#)

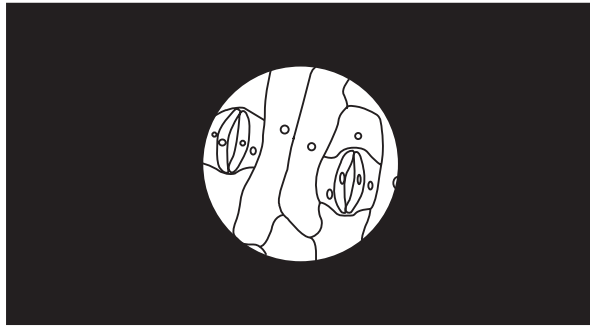

To display objects as seen through a microscope, use the included microscope adapter.



- Adjust the focus and zoom of a microscope before attaching to the document camera.
- Images may not be displayed correctly depending on the optical properties of your microscope.

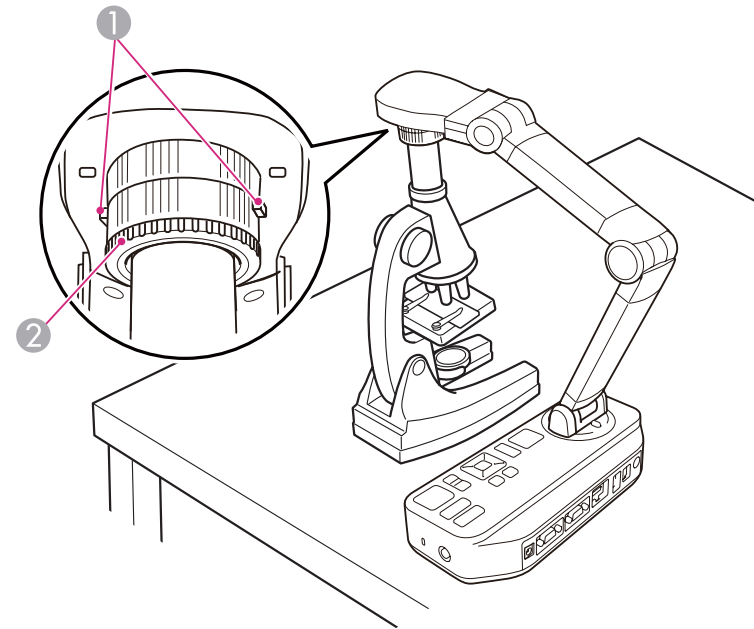

- ① Buttons
- ② Adapter ring

- 1** Attach the microscope adapter to the image rotation dial. Press the buttons and push the adapter in.
- 2** Place the camera head with the adapter directly over the microscope lens. Fit the adapter to the diameter of the eyepiece by pulling out the adapter ring. It extends up to about 5 mm (1/4 inch).
- 3** Press the [Menu] button and select **Image > Microscope > On**. This optimizes the image settings for use with a microscope.



If you manually adjust the brightness or zoom after setting **Microscope** to **On** in step 3, **Microscope** is automatically set to **Off**.

When a USB mouse is connected to the document camera, the annotation tools are displayed on the live camera image and you can add handwritten or graphic annotations with the USB mouse.

-  • You can only use the annotation function when the live camera image is displayed.
- USB mouse devices that require installation of a driver cannot be used. Also, some USB mouse models may not be compatible.

1 Connect a USB mouse to the document camera.

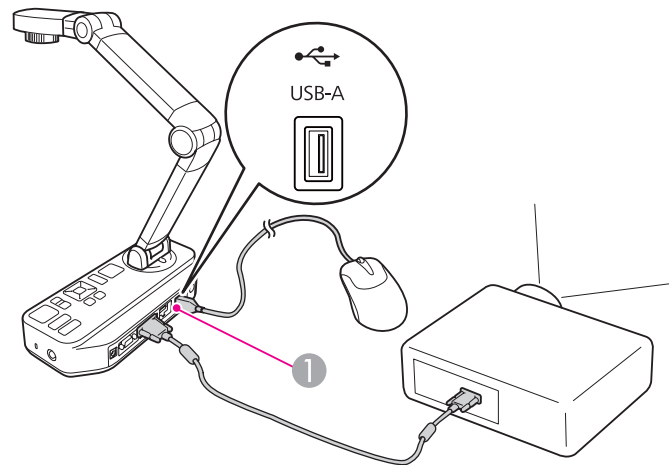

① USB-A port

2 The annotation tool bar is displayed on the bottom of the screen.

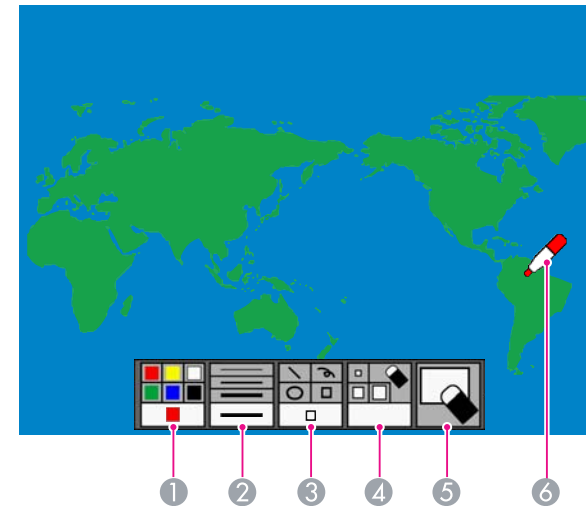

	Tool	Function
①	Colors	Selects a color for the annotation.
②	Line width	Selects a line width for the annotation.
③	Graphics	Changes a graphic (straight, freehand, circle, or square).
④	Eraser	Clears an annotation with the selected eraser size.
⑤	Clear all	Clears all annotations.
⑥	Pointer	Selects a tool and adds annotations. The shape of the pointer varies depending on the button or tool that you select.

3 Select a tool. Click the icon with the left mouse button on the annotation tool bar.

For example, when you draw a square:

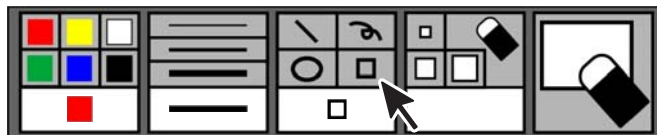

Use the left mouse button to draw lines or graphics or erase with an eraser.

4 Disconnect the USB mouse to end the annotation.



- You cannot use the on-screen menu while annotating.
- Images with your annotations cannot be saved.

If you've connected a computer (👉 p.22), you can show PowerPoint slides or images from any other application on your computer. You can easily switch back-and-forth between your computer application and the live camera image.

- If you've connected your computer with a USB cable (👉 p.22), you can use the document camera software to display captured images and videos, or use another application of your choice. To display the live camera image, make sure you've selected  **Capture** mode in the document camera software. 👉 p.56
- If you've connected your computer with a VGA cable (👉 p.23), use the document camera's [Source] buttons to switch between your computer and the live camera image:

To display your computer image (such as a PowerPoint presentation), press the [Source] - [] button on the document camera or remote control.

To switch back to the live camera image, press the [Source] - [] button.

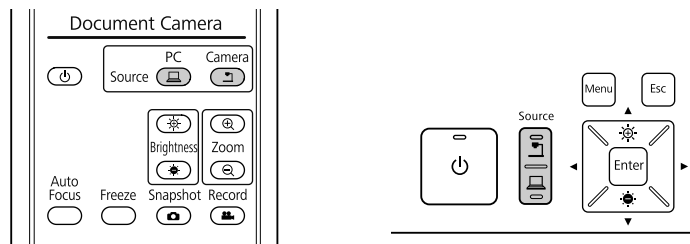

If you have images saved in the document camera's internal memory or on an SD card or USB drive (☛ p.38), you can display two images at the same time.



When connecting to a computer with a USB cable, you cannot use this function.

1 Press the [Menu] button and select **Memory > Split Screen**.

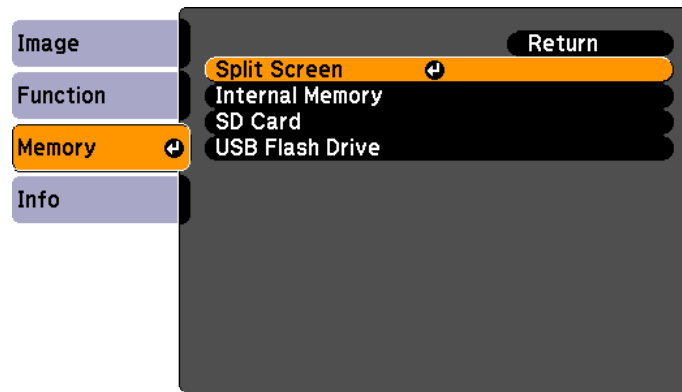

You see this setup screen, with the left image highlighted:

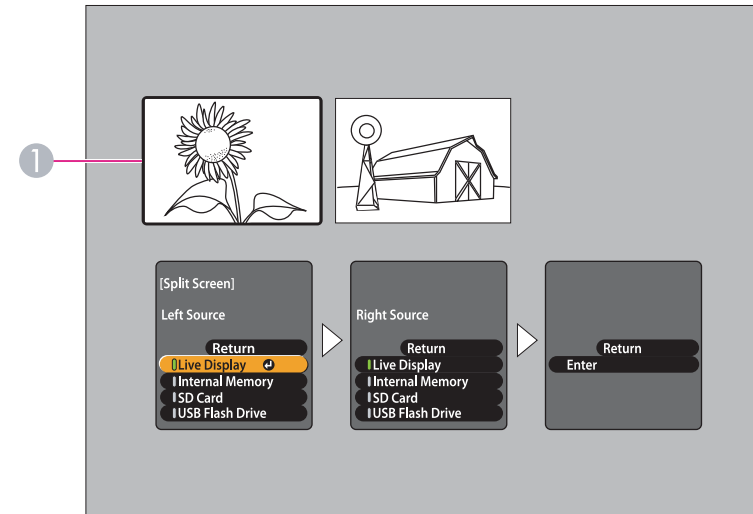

1 Highlighted image

2 Use the [▲] and [▼] arrow buttons to select the source for the highlighted image. You can select from these sources:

- **Live Display** to display the camera image
- **Internal Memory** to display an image stored in internal memory
- **SD Card** to display an image stored on an SD card, if one is inserted
- **USB Flash Drive** to display an image stored on a USB drive, if one is connected



- Images on the SD card or USB drive must be stored in the proper format to be readable. ☛ p.67
- When **USB Flash Drive** is not displayed, even if one is connected, set **USB Mode** to **Application**.

3 Press the [Enter] button to confirm the selection.

- 4** If you select **Internal Memory**, **SD Card**, or **USB Flash Drive** as the source, you see a screen that lets you select which image to use:

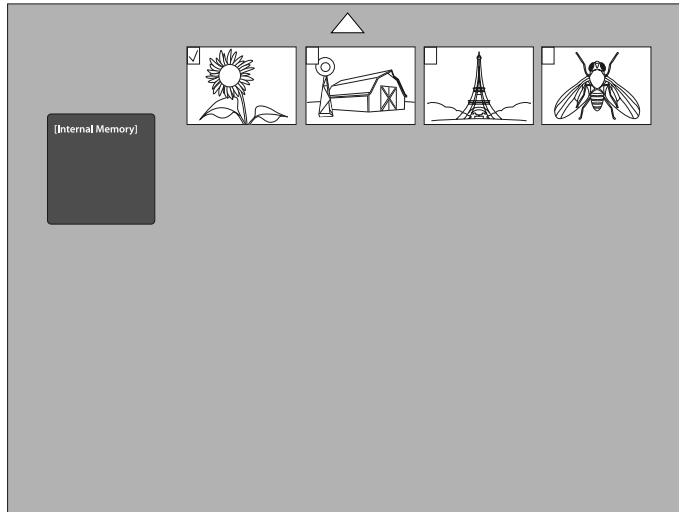

Use the [▲] [▼] [◀] [▶] arrow buttons to highlight the image you want to display, and press [Enter] to select it. Select **Return** to finish setting up the split screen.

- 5** Repeat steps 2 through 4 to select the source for the right side.



You cannot display the live camera image or video on both sides of the screen.

- 6** Once you're done setting up both sides of the screen, press [▶] then press [Enter]. The selected images appear side-by-side on the screen.



When connecting to a projector with an HDMI cable, the movie's audio is also played.

- 7** To exit split screen mode, press [Menu] or [Esc].

Saving Images and Displaying a Slideshow

Images captured by the document camera can be saved not only in the internal memory but also on an SD card or USB drive. Also, stored images can be imported or exported between the document camera and an SD card or USB drive. You can view them as a slideshow or on a connected computer.



- SD and SDHC cards are supported.
- When you save images on the SD card, make sure that it is not set to LOCK (write-protected).
- USB drives with a security function cannot be used.
- When connecting to a computer with a USB cable, you cannot use the functions described in this chapter except for  "Viewing and Managing Files from Your Computer" [p.44](#).

Captured still images are stored in the internal memory, an SD card, or a USB drive. If there is more than one save destination, the priority is as follows: USB drive > SD card > the internal memory. If the save destination only has a small capacity remaining, the image is saved in the next destination.



Images are saved in JPEG format.

- 1 Insert an SD card face-up or connect a USB drive, if needed.

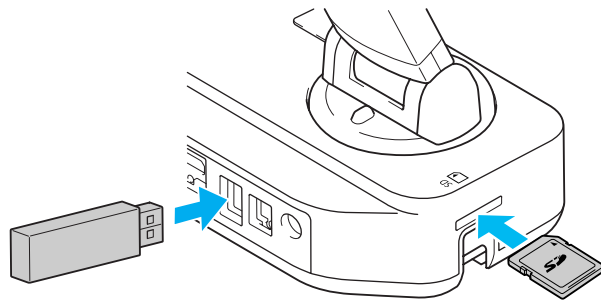

When you store images on a USB drive, make sure you set **Function > USB Mode to Application**.

- 2 Display the live camera image you want to save. Adjust any settings, as needed.
- 3 Press the  button to capture the image. Press and release when you use the remote control, press and hold when you use the control panel.

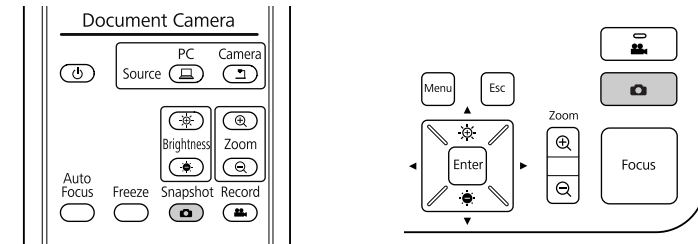

You see the  displayed in the upper right of the screen, and the image is saved.



Using the control panel, if you press and release the button without holding it, the image is frozen on the screen instead of being saved in memory.

- 4 Repeat steps 2 and 3 for any additional images you want to save.



- If all of the save destinations only have a small capacity remaining, "The memory is full." is displayed and the image is not saved.
- Do not disconnect the power cable from the document camera or remove an SD card or USB drive from the document camera while exporting data. Otherwise, the data may not be saved properly.

The document camera's live image is recorded in the internal memory, an SD card, or a USB drive. If there is more than one save destination, the priority is as follows: USB drive > SD card > the internal memory. If the save destination only has a small capacity remaining, the image is saved in the next destination.

- Movies are saved in AVI format. (Motion JPEG+PCM)
- You can record up to 2GB for each file.

1 Insert an SD card face-up or connect a USB drive, if needed.

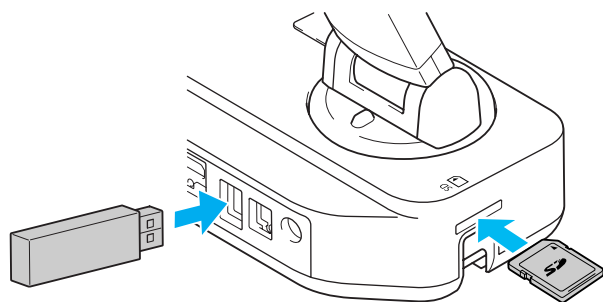

- When you store images on a USB drive, make sure you set **Function > USB Mode to Application.**

2 Display the live camera image you want to save. Adjust any settings, as needed.

- Motor noises by zoom or focus may be picked up by the internal microphone. Make sure you adjust the zoom or focus settings before starting a recording, or use an external microphone to record the audio. [p.40](#)

3 Press the [👤] button to start recording.

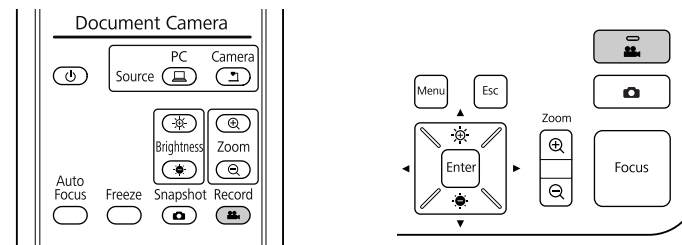

- The elapsed time displayed while recording is not displayed on the saved image.

4 To stop recording, press the [👤] button again.

- If all of the save destinations only have a small capacity remaining, "The memory is full." is displayed and the image is not saved.
- If the memory becomes full during recording, the image recorded up to that point is saved and recording stops.
- Do not disconnect the power cable from the document camera or remove an SD card or USB drive from the document camera while recording. Otherwise, the data may not be saved properly.

Connecting an External Microphone

If you connect an condenser microphone to the document camera, the audio from the microphone is also recorded along with a movie.



- Press the [Menu] button and select **Function > Ext. Mic. Volume** to adjust the recording volume of the external microphone.
- When an external microphone is connected, the internal microphone is disabled.
- Plug-in power is not supported.
- Live audio from a microphone cannot be output.

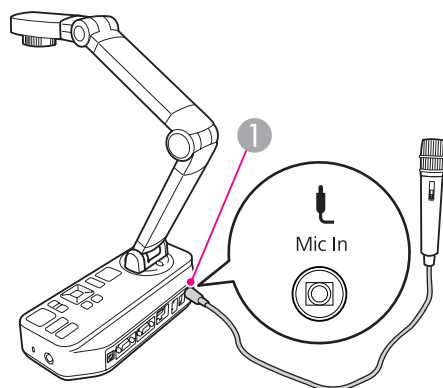

① Mic In port

The stored images in the internal memory can be exported to an SD card or USB drive. Also, the stored images on an SD card or USB drive can be imported to the internal memory. The steps below explain how to export images in the internal memory.

- 1 Insert an SD card face-up or connect a USB drive, if needed.

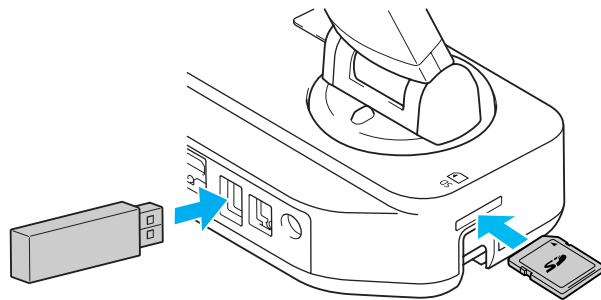

- 2 Press the [Menu] button and select **Memory > Internal Memory**.

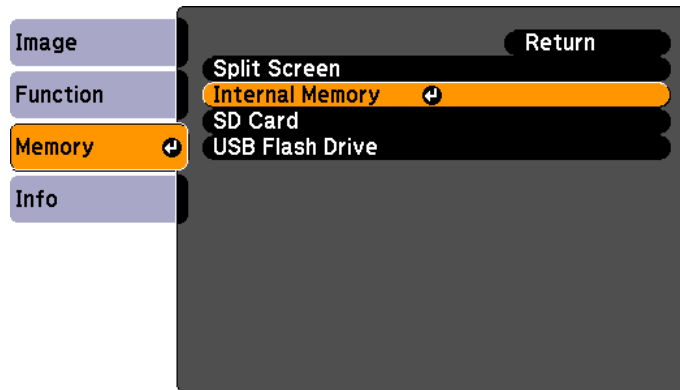

When importing images from an SD card or USB drive to the internal memory, select **SD Card** or **USB Flash Drive**.

You see this screen, showing the images stored in internal memory:

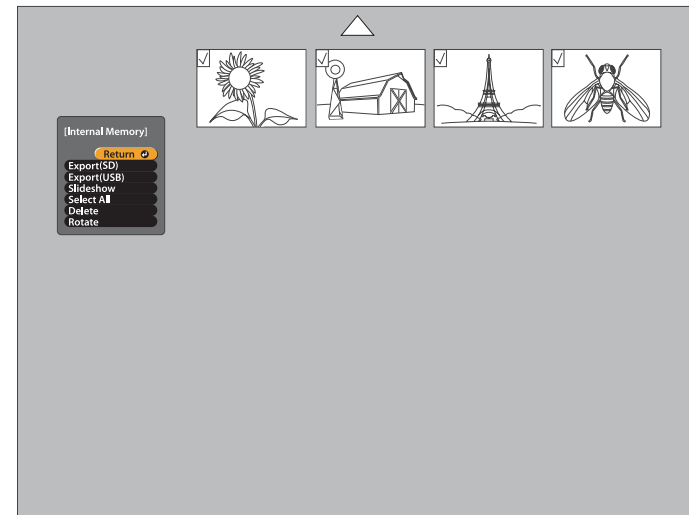

- 3 Use the [**▲**] [**▼**] [**◀**] [**▶**] arrow buttons to highlight each image you want to export, and press [Enter] to select it. (Press [Enter] again to deselect it.) A checkmark is added to each selected image.



To add checkmarks to all images, choose **Select All**. To remove all checkmarks, choose **Select All** again.

- 4 Select **Export(SD)** or **Export(USB)** and press [Enter].



When importing images from an SD card or USB drive to the internal memory, select **Import**.

- 5 Do one of the following:

- Disconnect the SD card or USB drive
- If you want to leave the SD card or USB drive in the document camera, press [Menu] or [Esc] to close the screen.



- If you want to remove the SD card, press in on the card and then pull it straight out of the slot. The SD Card screen automatically closes.
- When **USB Flash Drive** is not displayed even if one is connected, set **USB Mode** to **Application**.

You can use your computer with a USB cable to access files stored in the camera's internal memory. Before using the document camera like this, you have to change the function of its **USB** port as described below.

- 1** Connect the document camera to your projector with a VGA cable, composite video cable, or HDMI cable.  [p.20](#)
- 2** Turn on the document camera and projector.
- 3** Press the [Menu] button and select **Function > USB Mode**. Change the setting to **Mass Storage**.
- 4** Disconnect the projector from the document camera.
- 5** Now connect the document camera to your computer with a USB cable.

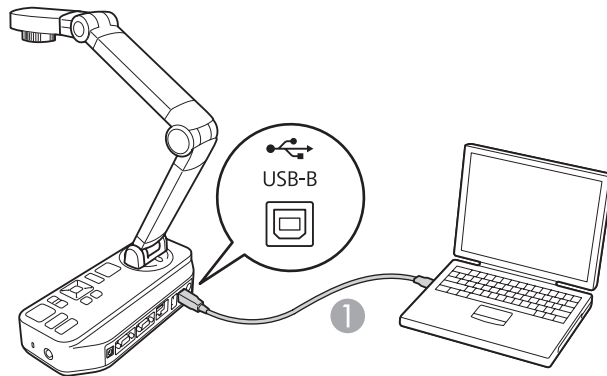

- 1** USB cable

The document camera's internal memory appears as an external drive on your computer.



- The document camera does not have a built-in clock. Therefore, when you view files from your computer, they won't show the actual time they were created.
- Connect the document camera to a USB 2.0 port of a computer. If you connect it to a USB 3.0 port, it may not function normally.

6

Use your computer to view the files, or to copy, move, or delete them.



- If you copy images from your computer to the document camera, they must be in the proper format to be readable.  [p.67](#)

7

When you're done, disconnect the computer.



Caution

Before disconnecting the USB cable, make sure your files have finished copying. Otherwise, they may be damaged.

8

Reconnect the projector.

9

Press the [Menu] button and select **Function > USB Mode**. Change the setting back to **Application**.



- If you don't change the setting back, you won't be able to see a live camera image when you use the document camera software. If you don't plan to use the software, you don't need to change the setting back.

Once you have stored images on the document camera's internal memory or on an SD card or USB drive, you can display a slideshow.

Attention

When you rotate an image, we recommend backing up data on the document camera's internal memory, USB drive, or SD card to another media.



In addition to images captured with the document camera, you can display images stored in the inserted SD card or connected USB drive. You can also display images copied to the document camera from your computer (see p.44), but they must be in the proper format.

see p.67

- 1 Press the [Menu] button and select **Memory**.
- 2 Select **Internal Memory** (to view images in internal memory), **SD Card** (to view images on your SD card, if inserted), or **USB Flash Drive** (to view images on your USB drive, if connected).

You see a screen like this:

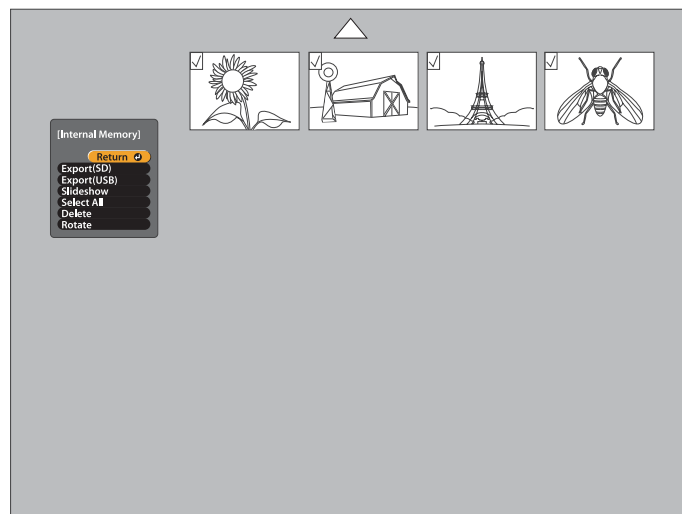

- 3 To rotate an image, use the [▲] [▼] [◀] [▶] arrow buttons to highlight it and press [Enter] to select it. (Press [Enter] again to deselect it.) A checkmark is added to the image. In the same way, select any additional images you want to rotate, and then select **Rotate**.

All checkmarked images are rotated 90 degrees clockwise.

Attention

When using this device to rotate and display images on the document camera's internal memory, a USB drive, or an SD card, the original image may be changed and then saved. You can only rotate up to 12 images at once.



Image quality may decrease slightly after rotating an image. Also, if your photo is time-stamped, the date will be changed to a default value.

- 4 Use the [▲] [▼] [◀] [▶] arrow buttons to highlight each image to be displayed in the slideshow, and press [Enter] to select it. (Press [Enter] again to deselect it.) A checkmark is added to the selected images.



To add checkmarks to all images, choose **Select All**. To remove all checkmarks, choose **Select All** again.

- 5 Select **Play/Slideshow** to display the first image in the slideshow. To start or stop the movie, press [Enter].



When connecting to a projector with an HDMI cable, the movie's audio is also played.

- 6** Press [▶] to advance to the next image.
Press [◀] to return to the previous image.

- 7** End the slideshow by pressing [▶] while the last image is displayed. Or press [Menu] or [Esc] to end the slideshow at any time.



Image Adjustments and Effects

The document camera provides a full range of image adjustments and effects, including freeze image, black-and-white, and the ability to display negative film in true color.

Press the [Menu] button on the document camera or remote control to view the on-screen menu. For details of each item in the screen menu, see [p.49](#).

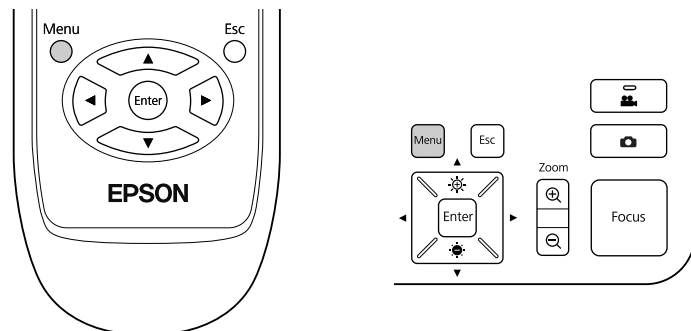

You see this screen:

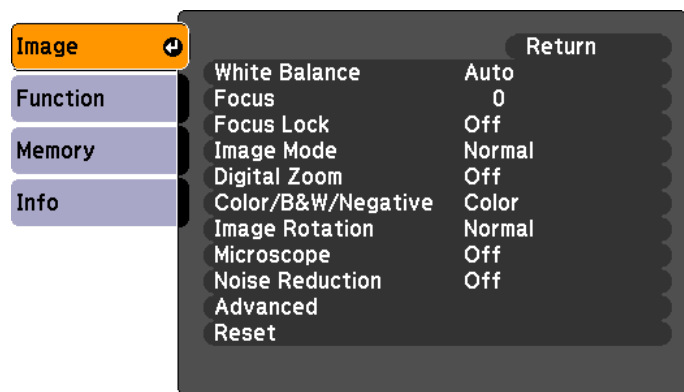

Use the [▲] [▼] [◀] [▶] arrow buttons to navigate the menu and adjust the settings. Press [Enter] to select a setting. When you're done adjusting the settings, press the [Menu] or [Esc] button to close the menu and save your settings.

Image Menu

Basic image adjustments such as focus, zoom, and brightness are discussed in "Displaying a Document or Other Materials" [p.26](#). You can make these further adjustments by pressing the [Menu] button to open the **Image** menu.



When projecting a live image, you can adjust the **Image** menu settings.

Setup Item	Explanation/Select
White Balance	Adjusts the image color based on the lighting in the room where you're presenting. Auto: Automatically adjusts the image color according to the display environment. Cloudy: Suitable for use in cloudy weather. Daylight: Suitable for use in fair weather. Fluorescent: Suitable for use in a room with fluorescent lighting. Incandescent: Suitable for use in a room with incandescent lamps.
Focus	Lets you manually adjust the focus if auto-focus doesn't produce a sharp enough image. Near: Adjusts the focus in. Far: Adjusts the focus out.
Image Mode	Selects the setting to adjust for the image type you are displaying from the camera. Normal: Default setting. Text: Suitable for projecting black-and-white text. Display: Suitable for directly projecting the display of a tablet PC etc.
Color/B&W/Negative	Displays the image in color or black-and-white. Color: Displays the image in color. Black&White: Displays the image in black-and-white. Negative: Displays the image as a negative.
Image Rotation	Lets you rotate an upside-down image. Normal: Displays the image as it actually is. 180 degrees: Displays the image upside-down.

Setup Item	Explanation/Select
Zoom Area Window	<p>Displays the entire image at the bottom-right of the screen with a box that indicates the section that is currently being enlarged by the zoom function.</p> <p>On: Enables Zoom Area Window.</p> <p>Off: Disables Zoom Area Window.</p>
Microscope	<p>Optimizes the image settings if using with a microscope.</p> <p> "Projecting Through a Microscope" p.31</p> <p>On: Sets the optimal image settings for use with a microscope.</p> <p>Off: Returns to the normal settings.</p>
Noise Reduction	<p>Settings related to Noise Reduction.</p> <p>On: Activates Noise Reduction. Use this setting if noise occurs.</p> <p>Off: Deactivates Noise Reduction. If the delay in projected images bothers you, select Off.</p>
Advanced	<p>Makes advanced settings of live image.</p> <p>Exposure: Adjusts the light volume of projected images. If the projected image is too dark or too bright to reproduce the original colors, you can adjust the light volume. Set it to a positive value if the overall image is dark and to a negative value if it is bright.</p> <p>Contrast: Adjusts the difference between bright and dark areas of images. Set it to a positive value to project vivid images and to a negative value to project monotone images.</p> <p>Color Adjustment: Adjusts the reddish and bluish colors of the whole image.</p> <p>Edge Enhancement: Adjusts the emphasis on the contours of the image. Set it to a positive value for sharp images and to a negative value for soft images.</p> <p>Gamma: Adjusts the coloring that occurs while displaying the image. When a smaller value is selected, the dark areas of images become brighter, but the lighter areas may become over-saturated. When a larger value is selected, you can reduce the overall brightness of the image to make the image sharper.</p>
Reset	<p>Resets the Image menu settings to the default value.</p>

Function Menu

Setup Item	Explanation/Select
USB Mode	<p>Changes how the document camera functions when connected with a USB cable.</p> <p>Application: Enables use of a USB drive and the included software. This is the default setting when turned on.</p> <p>Mass Storage: Lets you use a computer to view images stored in the internal memory.</p>
Ext. Mic. Volume	<p>Adjusts the recording volume from an external microphone.</p>

Setup Item	Explanation/Select
HDMI Output	Sets the output resolution when connecting with an HDMI cable. Auto: Automatically set according to the resolution of the output device. SDTV (480p) HDTV (720p) HDTV (1080p)
Output Resolution	Sets the output resolution when connecting with a VGA cable. Auto: Automatically set according to the resolution of the output device. XGA 1024x768 WXGA 1280x800 WXGA 1360x768 SXGA 1280x1024 Full HD 1920x1080
Video Format	Selects the video output signal. NTSC PAL
Flickerless	Eliminates flicker when giving presentations in regions with different electrical systems. 50Hz 60Hz
Language	Changes the on-screen menu language.
Sleep Mode	Operation settings when the document camera is inactive. On: The power automatically turns off if the document camera is inactive for a certain amount of time. Off: The power remains on even if the document camera is not being used.
Sleep Mode Timer	Sets the time from when the document camera is last operated until when the power automatically turns off. 1 to 6 hour(s)

Memory Menu

Setup Item	Explanation/Select
Split Screen	<p>Simultaneously displays two images from the internal memory, an SD card, a USB drive, or the live image.</p> <p>Left Source: Selects the image to be projected on the left side.</p> <p>Right Source: Selects the image to be projected on the right side.</p>
Internal Memory	<p>Operations related to the internal memory.</p> <p>Export(SD): Exports the selected images to an SD card.</p> <p>Export(USB): Exports the selected images to a USB drive.</p> <p>Play/Slideshow: Displays the selected images in a slideshow.</p> <p>Select All: Selects all images in the internal memory.</p> <p>Delete: Deletes selected images.</p> <p>Rotate: Rotates selected images 90 degrees clockwise and saves them.</p>
SD Card	<p>Operations related to an SD card.</p> <p>Import: Imports selected images to the document camera's internal memory.</p> <p>Play/Slideshow: Displays the selected images in a slideshow.</p> <p>Select All: Selects all images on an SD card.</p> <p>Delete: Deletes selected images.</p> <p>Rotate: Rotates selected images 90 degrees clockwise and saves them.</p>
USB Flash Drive	<p>Operations related to a USB drive.</p> <p>Import: Imports selected images to the document camera's internal memory.</p> <p>Play/Slideshow: Displays the selected images in a slideshow.</p> <p>Select All: Selects all images on a USB drive.</p> <p>Delete: Deletes selected images.</p> <p>Rotate: Rotates selected images 90 degrees clockwise and saves them.</p>

Info Menu

Setup Item	Explanation
Memory Capacity	Free Space: Displays the remaining capacity of the document camera's internal memory. Total Size: Displays the total capacity of the document camera's internal memory.
Number of Files	Displays the number of files saved in the document camera's internal memory.
Version	Displays the firmware version of the document camera.



Using the Included Software

The included software lets you use the document camera to capture still images, make time-lapse movies, record live videos with audio, and edit and play back captured files. The software also lets you annotate images from the document camera with text and graphics, and upload your videos to popular websites.

Before starting, follow the instructions in this section to install the software.



For detailed help when using the software, do one of the following:
Windows: Press **F1** or select **Application Help** from the **Extras** menu.
Mac OS X: Select **Help** from the menu bar.

You can install the software on a Windows or Mac OS X computer. See [p.82](#) for system requirements.

- 1** Press the [⏻] power button to turn on the document camera.
- 2** Connect the document camera to your computer with a USB cable.  [p.22](#)
- 3** Insert the CD labeled "**EPSON Document Camera Software**" into your computer.
- 4** When you see the license agreement, click **Yes**.
- 5** Follow the instructions on the screen to install all the software.



When you see a screen asking if you want to install the **Button Manager** and **TWAIN Driver for Epson Document camera** (Windows only), be sure to allow the software to install.

Uninstalling the Software

Follow these steps if you need to uninstall the software.

Windows 8

- 1** Select **Search** on the Charms, and then right-click (press and hold) **ArcSoft Application Software for Epson Document Camera**.
- 2** Select **Uninstall** from the app bar.
- 3** Select **ArcSoft Application Software for Epson Document Camera**, and then select **Uninstall**.

Windows 7/Windows Vista/Windows XP

- 1** Windows 7/Windows Vista: Select **Control Panel > Programs and Features**. In Classic View, select **Programs > Uninstall a program** instead.
Windows XP: Select **Control Panel > Add or Remove Programs**.
- 2** Select **ArcSoft Application Software for Epson Document Camera**.
- 3** Windows 7/Windows Vista: Click **Uninstall/Change**.
Windows XP: Click **Change/Remove**.

Mac OS X

- 1** Open the **Applications** folder.
- 2** Drag the **ArcSoft Application Software for Epson Document Camera** to the **Trash**.

- 1** Connect the document camera to a computer with a USB cable.
☞ p.22
- 2** Start the software:
 - Windows 8: Select **Search** on Charms, and then select **ArcSoft Application Software for Epson Document Camera**.
 - Windows 7/Windows Vista/Windows XP: From **Programs** or **All Programs**, select **ArcSoft Application Software for Epson Document Camera**. If the software does not start, install the **Windows Media Player**.
 - Mac OS X: Open the **Applications** folder, then double-click **ArcSoft Application Software for Epson Document Camera**.You see the screen shown below.



If you see a message that the document camera is not found, make sure it is connected and turned on. Then click the **Connect** button in the upper-right corner of the screen.

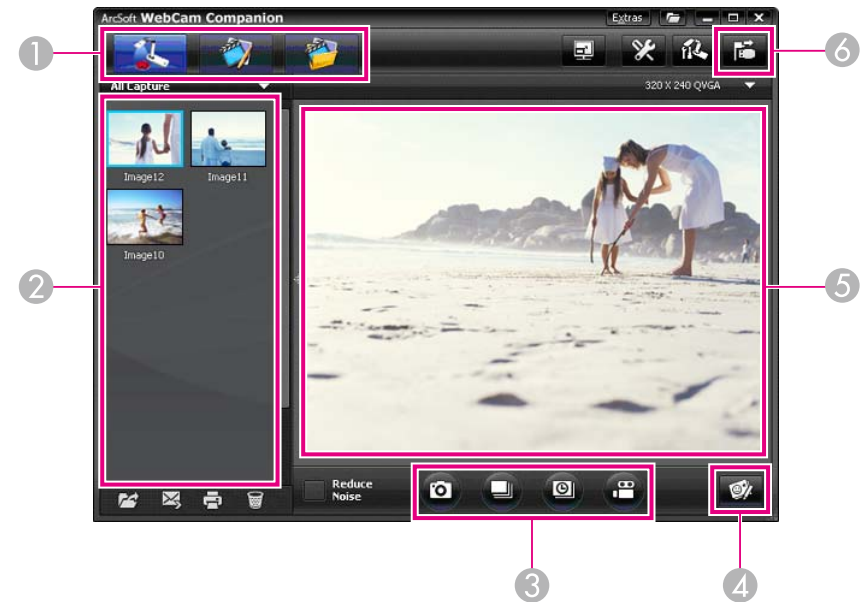

- 1** Main modes (capture, edit, and file management)
- 2** Capture album (previously captured images)
- 3** **Capture** buttons (still image, burst, time-lapse, and video)
- 4** **Live Annotation** button
- 5** Preview area (live camera image)
- 6** **Connect** button

You can annotate live images from the document camera with text and graphics while giving a presentation. When you capture an image, your annotations will be included with the image; if you record your presentation as a video, the recording will show your annotations as they're being added.



You can also annotate still images after they've been captured using the Edit screen. [p.62](#)

1 If necessary, click the  **Capture** button to enter Capture mode. Your live camera image appears in the preview area.

2 Click the **Live Annotation** button.



3 Select a drawing tool, such as **Pen**, **Line**, or **Text**.

4 Change the properties of the selected tool.

5 Use the selected tool to add text and graphics.

6 To clear an annotation, use the **Eraser** tool or click the **Undo** button to clear the last change you made. To clear all annotations, select the **Eraser** tool and then click the **Clear all** button that appears above the preview area.

To save an annotated image, click the **Take Picture** button at the bottom of the screen. [p.58](#)

To record a video that shows annotations as they're being made, see [p.60](#).

You can capture a still image or a quick series of images (called a burst).

- 1** If necessary, select the settings you want to use. Click the **Settings** button and select the **Image** tab.
 - Select the default image format, quality level, and other properties.
 - Choose the number of photos, up to 10, that will be captured with each burst (5 is the default).
- 2** To capture a still image, click the **Take Picture** button.
- 3** To capture a quick series of images, click the **Burst** button.



Your captured image(s) appear in the Capture album on the left side of the screen. To display a captured image through your projector, double-click the image or right-click it and select **Preview**.

You can record a time-lapse movie to show gradual changes that occur over several hours.

- 1 Click the **Settings** button and select the **Time Lapse** tab.
 - Set the time interval between each frame (5 seconds minimum).
 - Set the total capture duration (up to 72 hours).Click **OK** to close the Settings screen.

- 2 Click the **Start Time Lapse** button to begin capturing images.



When the process is done, the time-lapse movie or image appears as an icon in the Capture album on the left side of the screen. To display the movie through your projector, double-click the icon or right-click it and select **Preview**.

You can make an audio/video recording of your presentation. Set the resolution under Full HD (1920×1080).

1 If necessary, select the settings you want to use. Click the **Settings** button and select the **Video** tab.

- Select the default video format, quality level, and other properties.
- Set the maximum duration of each video (up to 8 hours) and see how much hard disk space it will use.

2 To capture sound, click the **Settings** button, select the **Audio** tab, and select **ELPDC12** from **Audio Device**.

3 Click the **Record Video** button to start recording. Click **Record Video** again to stop.

You can also use the [👤] button on the control panel to start and stop recording.



To start recording using the [👤] button, Button Manager needs to be installed and running on your computer.



Your movie appears as an icon in the Capture album on the left side of the screen. To display the movie through your projector, double-click the icon or right-click it and select **Preview**.

When you connect with the computer, you cannot use two document cameras at the same time.

Compatible File Format

Type	Extension
Still images	.jpg/.bmp

Type	Extension
Videos	Windows: .wmv (WMV2+WMA) .avi (YUV+PCM) .mpg (MPEG Video+ MPEG Audio) Mac OS X: .mov (Motion JPEG+PCM)

You can use the Edit screen to improve the quality (such as brightness and contrast) of captured pictures and videos. With still images, you can zoom in on part of the image, rotate the image, or flip it to create a mirror image. You can also annotate still images. While viewing a video, you can pause it and capture a still image from the current frame.

- 1 Click the  **Edit** button to enter Edit mode.

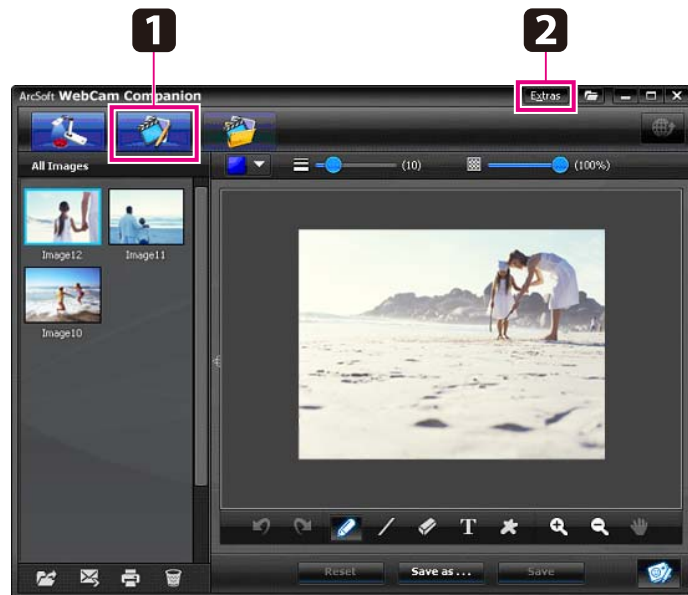

- 2 For detailed help when using the software, do one of the following:
Windows: Press **F1** or select **Application Help** from the **Extras** menu.
Mac OS X: Select **Help** from the menu bar.

You can use the File Management screen to sort and locate captured images and videos. By rating them and applying "tags" or descriptive text, you can make it easier to find them later on.

- 1 Click the  **File Management** button to enter **File Management** mode.

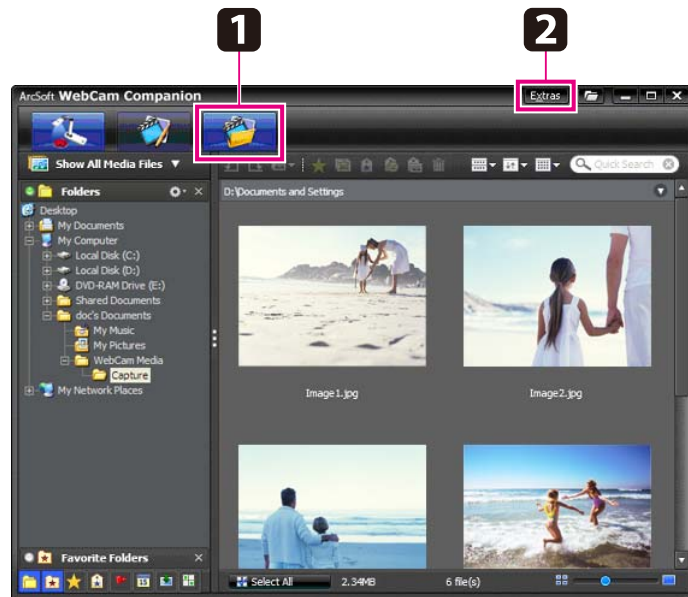

- 2 For detailed help when using the software, do one of the following:
Windows: Press **F1** or select **Application Help** from the **Extras** menu.
Macintosh: Select **Help** from the menu bar.

You can easily upload your videos to popular video-sharing websites, such as YouTube and SchoolTube.



This feature is not available for Apple Macintosh systems.

- 1 Click the  **Edit** button.

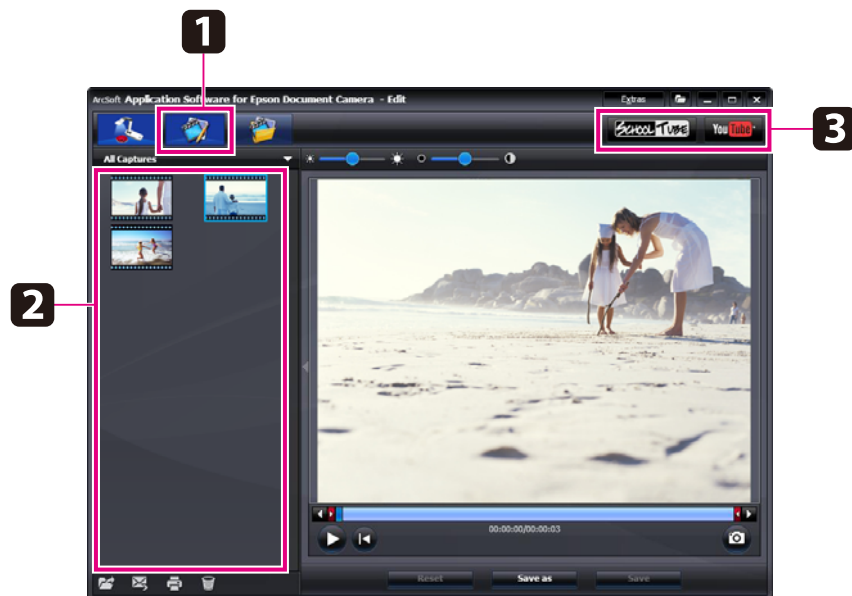

- 2 Select a video.
- 3 Select a website.
- 4 Follow the instructions on the screen to log in, provide a title for your video and other descriptive information, and upload the file.



Solving Problems

Operation Problems

No image appears on the screen

- After you press the [⏻] Power button, wait a few moments for the image to appear. It takes about 20 seconds for the document camera to output an image.
- Make sure your projector is connected. 🖱️ [p.20](#)
If you're connecting it through a computer, see [p.22](#).
- If you've connected a laptop, see "Problems Connecting a Laptop" [p.67](#).
- The document camera may be set to display an image from your computer. Press the [Source] - [🖥️] button on the document camera or remote control to display the live camera image.
- Select the correct source on your projector. The source refers to the port on the projector to which you've connected the video cable. If you're using a VGA cable, the source may be called something like "Computer" or "PC".
- Make sure your projector is turned on and not in sleep mode. Make sure its picture has not been "muted" or turned off.
- If you made a USB connection, the document camera's **USB Mode** setting may be set to **Mass Storage**.
You need to change this setting to **Application**. First disconnect the USB cable, then reconnect to the projector using a VGA cable, composite video cable, or HDMI cable. Press the [Menu] button and select **Function** > **USB Mode**, then change the setting to **Application**.
Now you can use the USB cable to display the image.

Image Quality Problems

The image is fuzzy or out of focus

- The document camera needs hard edges or sharp lines in the image to be able to focus properly. If the image has only soft edges, try placing a different document under the camera lens while adjusting the focus. Or focus the image manually with the **Focus** adjustment in the **Image** menu. 🖱️ [p.49](#)
- Make sure the lens is at least 10 cm (4 inches) away from the object you're viewing.
- If you're using a projector to display the image, check its focus.

The image brightness or color isn't correct

- To illuminate your document, slide the lamp switch on the side of the camera head.
- Press the [-☀️] or [☀️+] button to increase or decrease image brightness.
- Set the **White Balance** setting to **Auto** to adjust the color automatically. 🖱️ [p.49](#)
If the color is still not correct, choose the setting for the type of lighting you're presenting under (**Cloudy**, **Daylight**, **Fluorescent**, or **Incandescent**).
- If the document camera was used with a microscope, be sure to turn the **Microscope** setting off when you return to displaying ordinary documents. 🖱️ [p.49](#)

Other image problems

- If the image is stretched or has black bars, you may need to change the **Output Resolution** in the **Function** menu.



If you think some settings may have been changed, you can use the **Reset** option to return all the image settings back to their standard values except the **Output Resolution** setting. 🖱️ [p.50](#)

Problems Using an SD Card

Certain images don't appear

If you use your computer to copy images to the document camera's internal memory or an SD card, you need to make sure their format is correct:

- Images must be DCF-compliant JPEG files to be displayed, such as from a digital camera. Avoid editing your images, as this may change their format and prevent them from being displayed.
- Images must be named using the format ABCD1234.JPG, where ABCD is any combination of upper- or lowercase letters and 1234 is any combination of numbers. For example: Pict0001, Pict0002, etc.
- Images must be placed in a folder named DCIM\123ABCDE, where 123 is any combination of numbers and ABCDE is any combination of upper- or lowercase letters. If this folder structure doesn't exist, first create a folder named DCIM, then create a folder within it with the desired name (for example, 100EPSON).

Image files don't have the correct time stamp

The document camera does not have a built-in clock. Therefore, when you view captured image files from your computer, they won't show the actual time they were created.

Problems Using a USB Drive

Images stored on a USB drive are not displayed

The document camera's **USB Mode** setting may be set to **Mass Storage**. Press the [Menu] button and select **Function > USB Mode**, then change the setting to **Application**.

There are no images stored on the USB drive

The document camera's **USB Mode** setting may be set to **Mass Storage**. Press the [Menu] button and select **Function > USB Mode**, then change the setting to **Application**.

Image files don't have the correct time stamp

The document camera does not have a built-in clock. Therefore, when you view captured image files from your computer, they won't show the actual time they were created.

Problems Connecting a Laptop

If you've connected a laptop computer ([p.22](#)) but the image doesn't appear on the screen, check the following:

• Windows:

Hold down the **Fn** key and press the function key (such as **⌘/□** or **CRT/LCD**) that lets you display on an external monitor. On most systems, the **⌘/□** or **CRT/LCD** key lets you toggle between the LCD screen and the projector, or display on both at the same time. Check your monitor settings to make sure both the LCD screen and the external monitor port are enabled. From the **Control Panel**, open the **Display** utility. Click the **Settings** tab, then click **Advanced**. The method for adjusting the settings varies by brand; you may need to click a **Monitor** tab, then make sure the external monitor port is set as your primary display and/or enabled. See your computer's documentation or online help for details.

• Mac OS X:

From the **Apple** menu, select **System Preferences**, then click **Display** or **Displays**. Select **VGA Display** or **Color LCD**, click **Arrangement** or **Arrange**, and make sure **Mirror Displays** is checked.

Problems Using the Document Camera Software

The buttons on the document camera don't work with the software

When you installed the software, the **Button Manager** and **TWAIN Driver for Epson Document camera** (Windows only) weren't installed. Reinstall all



the software, being sure to allow the **Button Manager** and **TWAIN Driver for Epson Document camera** to install.

You don't see the live camera image on your computer

The document camera's **USB Mode** setting may be set to **Mass Storage**. You need to change this setting to **Application**. First disconnect the USB cable, then reconnect to the projector using a VGA cable, composite video cable, or HDMI cable. Press the [Menu] button and select **Function > USB Mode**, then change the setting to **Application**. Now you can use the USB cable to display the image.

Addresses and phone numbers are subject to change. For the most current information, check the website of your regional sales office listed below. If you don't find one in your area, visit Epson's main website at www.epson.com.

Europe, Middle East & Africa

ALBANIA

ITD Sh.p.k.

Gjergji Center
Rr Murat Toptani
04000 Tirana
Albania
Tel: 00355 4 2256031
Fax: 00355 4 2256013
<http://www.itd-al.com>

AUSTRIA

Epson Deutschland GmbH

Buopark Donau Inkustrasse 1-
7 / Stg. 6 / 2. OG
A-3400 Klosterneuburg
Austria
Tel: +43 (0) 2243 - 40 181 - 0
Fax: +43 (0) 2243 - 40 181 - 30
<http://www.epson.at>

BELGIUM

EPSON Europe B.V. Branch office Belgium

Belgicastraat 4 - Keiberg
B-1930 Zaventem
Belgium
Tel: +32 2/ 7 12 30 10
Fax: +32 2/ 7 12 30 20
Hotline: 070 350120
<http://www.epson.be>

BOSNIA AND HERZEGOVINA

NET d.o.o. Computer Engineering

Vukovarska 24
88000 Mostar
Bosnia and Herzegovina
Tel: 00387 36449660
Fax: 00387 36449669
E-mail: info@net.com.ba
<http://www.net.com.ba>

BULGARIA

EPSON Service Center, Bulgaria

c/o ProSoft Central Service
Akad. G. Bonchev SRT. bl.6
1113 Sofia, Bulgaria
Tel: 00359 2 979 30 75
Fax: 00359 2 971 31 79
Email: info@prosoft.bg
<http://www.prosoft.bg>

CROATIA

MR servis d.o.o.

Dugoselska cesta 5
10370 Rugvica, Croatia
Tel: 00385 16401111
Fax: 00385 13654982
E-mail: info@mrservis.hr
<http://www.mrservis.hr>

CYPRUS

Mechatronic Ltd.

88 Digenis Akritas Avenue
"Loizides Centre 2" - 2nd Floor
CY-1061 Nicosia, Cyprus
Tel: 00357 22582258
Fax: 00357 22582222
<http://www.mechatronic.com.cy>

CZECH REPUBLIC

Epson Europe B.V. Branch Office Czech Republic

Slavickova 1a 63800 Brno
Czech Republic
Hotline: 800 142 052
E-mail: infoline@epson.cz
<http://www.epson.cz>

DENMARK

EPSON Denmark

Transformervej 6 2730 Herlev, Denmark
Tel: 44508585
Fax: 44508586
Hotline: 80808047
Email: danmark@epson.dk
<http://www.epson.dk>

ESTONIA

EPSON Service Center, Estonia

c/o Kulbert Ltd. Sirge 4, 10618
Tallinn, Estonia
Tel: 00372 671 8160
Fax: 00372 671 8161
<http://www.epson.ee>

FINLAND

Epson Finland

Rajatorpantie 41 C FI-01640
Vantaa, Finland
Hotline: 0201 552090
<http://www.epson.fi>

FRANCE and DOM-TOM TERRITORIES

EPSON France S.A.

150 rue Victor Hugo BP 320
92305 LEVALLOIS PERRET
Cedex, France
Hotline: 0821017017
<http://www.epson.fr>

GERMANY

EPSON Deutschland GmbH

Otto-Hahn-Strasse 4 D-40670
Meerbusch, F.R. Germany
Tel: +49-(0)2159-538 0
Fax: +49-(0)2159-538 3000
Hotline: 01805 2341 10
<http://www.epson.de>

GREECE

Oktabit S.A.

Gounari 26,
15343 Agia Paraskevi
Greece
Tel: 0030 210 6067181
Fax: 0030 210 6067180
<http://www.oktabitgr.com>

HUNGARY

Epson Europe B.V. Branch Office Hungary

Infopark setany 1.
H-1117 Budapest, Hungary
Hotline: 06 800 14 783
E-mail: infoline@epson.hu
<http://www.epson.hu>

IRELAND

Epson (UK) Ltd.

Westside, London Road
Hemel Hempstead, Herts HP3 9TD, U.K.
Hotline: 01 679 9015
<http://www.epson.ie>

ISRAEL

Epson Israel

2 Habonim st.
Ramat Gan, Israel
Tel: +972-3-5751833
Fax: +972-3-575161
<http://www.epson.co.il>

ITALY

EPSON Italia s.p.a.

Via M. Vigano de Vizzi, 93/95
20092 Cinisello Balsamo
Mirano, Italy
Tel: +39 06. 660321
Fax: +39 06. 6123622
Hotline: +39 06.60521503
<http://www.epson.it>

KAZAKHSTAN

EPSON Kazakhstan Rep Office

97, Samal-2, bldg A1, 5th floor
Business Center "Samal Towers"
Almaty 050051, Kazakhstan
Phone +7 727 3560260
Fax +7 727 3560260
<http://www.epson.kz>

LATVIA

EPSON Service Center, Latvia

c/o ServiceNet LV
Jelgavas 36
1004 Riga, Latvia
Tel.: 00 371 746 0399
Fax: 00 371 746 0299
<http://www.epson.lv>

LITHUANIA

EPSON Service Center, Lithuania

c/o ServiceNet
Gaiziunu 3
50128 Kaunas, Lithuania
Tel.: 00 370 37 400 160
Fax: 00 370 37 400 161
<http://www.epson.lt>

LUXEMBURG

EPSON Europe B.V. Branch office Belgium

Belgicastraat 4-Keiberg
B-1930 Zaventem
Belgium
Tel: +32 2/ 7 12 30 10
Fax: +32 2/ 7 12 30 20
Hotline: 0900 43010
<http://www.epson.be>

MACEDONIA

Digit Computer Engineering

Bul. Partizanski Odredi 62 Vlez
II mezanin
1000 Skopje, Macedonia
Tel: 00389 2 3093393
Fax: 00389 2 3093393
E-mail: digit@digit.com.mk
<http://www.digit.com.mk>

NETHERLANDS

Epson Europe B.V. Benelux sales office

Entrada 701
NL-1096 EJ Amsterdam
Netherlands
Tel: +31 20 592 65 55
Fax: +31 20 592 65 66
Hotline: 0900 5050808
<http://www.epson.nl>

NORWAY

Epson Norway

Fjordveien 3
1363 Høvik, Norway
Tel: 4780030030
E-mail: ksbl@telenor.com
<http://www.epson.no>

POLAND

Epson Europe B.V. Branch Office Poland

Ul. Bokserska 66 PL-02-690
Warszawa, Poland
Hotline: (0) 801-646453
<http://www.epson.pl>

PORTUGAL

Epson Iberica S.A.U.Branch Office Portugal

Rua Gregorio Lopes, Lote 1514,
Restelo, 1400 Lisboa, Portugal
Tel: 213035400
Fax: 213035490
Hotline: 707 222 000
<http://www.epson.pt>

ROMANIA

Epson Europe B.V.Branch Office Romania

Strada Ion Urdareanu nr. 34
Sector 5, 050688 Bucuresti
Romania
Tel: 00 40 21 4025024
Fax: 00 40 21 4025020
<http://www.epson.ro>

RUSSIA

Epson CIS

Schepkina street, 42, Bldg 2A,
3rd floor
129110, Moscow, Russia
Tel: +7 (495) 777-03-55
Fax: +7 (495) 777-03-57
<http://www.epson.ru>

UKRAINE

Epson Kiev Rep. Office

Pimonenko street, 13, Bldg 7B,
Office 15
04050, Kiev, Ukraine
Phone +38 (044) 492 9705
Fax +38 (044) 492 9706
<http://www.epson.ru>

SERBIA

AVG d.o.o. Beograd

Prve pruge 31c11080 Zemun, Beograd Republic of Serbia
Tel: 00381 11 3191868
E-mail: office@a-v-g.rs
<http://www.a-v-g.rs>

SLOVAKIA

Epson Europe B.V. Branch Office Czech Republic

Slavickova 1a 638 00 Brno
Hotline: 0850 111 429 (national costs)
Email: infoline@epson.sk
<http://www.epson.sk>

SLOVENIA

Birotehnna d.o.o

Litijska Cesta 259
1261 Ljubljana - Dobrunje
Slovenia
Tel: 00 386 1 5853 410
Fax: 00386 1 5400130
E-mail: info@birotehna.si
<http://www.birotehna.si>

SPAIN

Epson Ibérica, S.A.U.

Av. de Roma, 18-26
08290 Cerdanyola del Vallès
Barcelona, Spain
Tel: 93 582 15 00
Fax: 93 582 15 55
Hotline: 902 28 27 26
<http://www.epson.es>

SWEDEN

Epson Sweden

Box 329 192 30 Sollentuna
Sweden
Tel: 0771-400134
<http://www.epson.se>

SWITZERLAND

Epson Deutschland GmbH Branch office Switzerland

Zweigniederlassung Kloten
Steinackerstrasse 34
CH-8302 Kloten
Switzerland
Tel: +41 (0) 43 255 70 20
Fax: +41 (0) 43 255 70 21
Hotline: 0848448820
<http://www.epson.ch>

TURKEY

Tecpro Bilgi Teknolojileri Tic. ve San. Ltd. Sti.

Sti. Telsizler mah. Zincirli dere
Cad. No: 10 Kat 1-2
Kagithane 34410 Istanbul
Turkey
Tel: 0090 212 2684000
Fax: 0090212 2684001
E-mail: epson@tecpro.com.tr
<http://www.epson.com.tr>

UNITED KINGDOM

Epson (UK) Ltd.

Westside, London Road
Hemel Hempstead Herts HP3 9TD, U.K.
Tel: (01442) 261144
Fax: (01442) 227227
Hotline: 08704437766
<http://www.epson.co.uk>

Africa

Contact your dealer

Email: support@epson.co.za

<http://www.epson.co.za>

or

<http://www.epson.fr>

SOUTH AFRICA

Epson South Africa

Grnd. Floor. Durham Hse, Block 6
Fourways Office Park
Cnr. Fourways Blvd. & Roos Str.
Fourways, Gauteng. South Africa
Tel: +27 11 465 9621
Fax: +27 11 465 1542
Helpdesk: 0860 337766
or +27 11 201 7741
Helpdesk: 0860 337766
or +27 11 201 7741
Email: support@epson.co.za
<http://www.epson.co.za>

Middle East

Epson (Middle East)

P.O. Box: 17383 Jebel Ali Free
Zone Dubai
UAE (United Arab Emirates)
Tel: +971 4 88 72 1 72
Fax: +971 4 88 18 9 45
Email: supportme@epson.eu
<http://www.epson.ae>

North and Central America

CANADA

Epson Canada, Ltd.

185 Renfrew Drive
Markham, Ontario
L3R 6G3
Canada
Tel: 905-709-9475
or 905-709-3839
<http://www.epson.ca>

COSTA RICA

Epson Costa Rica, S.A.

De la Embajada Americana,
200 Sur y 200 Oeste
Pavas, San Jose
Costa Rica
Tel: 800-EPSONCR
(800-3776627)
<http://www.epson.co.cr>

MEXICO

EPSON Mexico, S.A. de C.V.

Boulevard Manuel Avila
Camacho 389
Edificio 1, Conjunto Legaria
Col Irrigación, C.P. 11500
México, DF
Tel: (52 55) 1323-2052
/ (52 55) 1323-2096
/ (52 55) 1323-2127
<http://www.epson.com.mx>

ECUADOR

Epson Ecuador

Tel: 604-4220 (Guayaquil)
Tel: 04-604-4220 (otras ciudades)
<http://www.epson.com.ec>

UNITED STATES

Epson America, Inc.

3840 Kilroy Airport Way
Long Beach, CA 90806
Tel: 562-276-4394
<http://www.epson.com>

South America

ARGENTINA

EPSON Argentina SRL.

Ave. Belgrano 970
(1092) Buenos Aires, Argentina
Tel: (54 11) 5167-0300
<http://www.epson.com.ar>

BRAZIL

EPSON do Brasil

Av. Tucunaré
720 Tamboré Barueri,
Sao Paulo, SP 06460-020
Brazil
Tel: (55 11) 3956-6868
<http://www.epson.com.br>

CHILE

Epson Chile S.A.

La Concepción 322 Piso 3
Providencia, Santiago, Chile
Tel: (562) 484-3400
<http://www.epson.cl>

COLOMBIA

Epson Colombia Ltd.

Calle 100 No 19-54 Piso 7
Bogota, Colombia
Tel: (57 1) 523-5000
<http://www.epson.com.co>

PERU

Epson Peru S.A.

Av. Canaval y Moreyra 590
San Isidro, Lima, 27, Perú
Tel: (51 1) 418 0210
<http://www.epson.com.pe>

VENEZUELA

Epson Venezuela S.A.

Calle 4 con Calle 11-1
La Urbina Sur.
Caracas, Venezuela
Tel: (58 212) 240-1111
<http://www.epson.com.ve>

3, Talavera Road
North Ryde, NSW 2113,
Australia
Tel: 1300 361 054
<http://www.epson.com.au>

CHINA

Epson (China) Co., Ltd.

7F, Jinbao Building,
No.89 Jinbao Street,
Dongcheng District,
Beijing,
China, 100005
Tel: (86-10) 85221199
FAX: (86-10) 85221123
Hotline: 400-810-9977
<http://www.epson.com.cn>

HONG KONG

Epson Hong Kong Ltd.

Unit 715-723, Trade Square,
681 Cheung Sha Wan Road,
Cheung Sha Wan, Kowloon,
HONG KONG
Support Hotline: (852) 2827 8911
Fax: (852) 2827 4383
<http://www.epson.com.hk>

INDIA

Epson India Pvt., Ltd.

12th Floor, The Millenia
Tower A, No. 1, Murphy Road, Ulsoor, Bangalore 560 008
India
Tel: 1800 425 0011
/1860 3000 1600
<http://www.epson.co.in>

Asia and Oceania

AUSTRALIA

Epson Australia Pty.Ltd

INDONESIA

PT. Epson Indonesia

Wisma Kyoei Prince, 16th Floor,
Jalan Jenderal Sudirman Kav. 3,
Jakarta 10220, Indonesia
Tel: 021-5723161
<http://www.epson.co.id>

JAPAN

SEIKO EPSON CORPORATION TOYOSHINA OFFICE

VP CS / Quality Assurance Dept.
6295 Tazawa, Toyoshina, Azumino-shi,
Nagano-ken, 390-8285
Tel: 0263-87-5814
Fax: 0263-87-5813
<http://www.epson.jp>

KOREA

EPpson Korea Co., Ltd.

11F Milim Tower, 825-22
Yeoksam-dong, Gangnam-gu,
Seoul, 135-934 Korea
Tel: 82-2-558-4270
Fax: 82-2-558-4272
<http://www.epson.co.kr>

MALAYSIA

Epson Malaysia Sdn. Bhd.

3rd Floor, East Tower, Wisma Consplant 1
No.2, Jalan SS 16/4,
47500 Subang Jaya,
Malaysia.
Tel: 03 56 288 288
Fax: 03 56 212 088
<http://www.epson.com.my>

NEW ZEALAND

Epson New Zealand

Level 2,
7-9 Fanshawe Street,
Auckland Central, 1010
New Zealand
Tel: 09 366 6855
Fax 09 366 6865
<http://www.epson.co.nz>

PHILIPPINES

Epson Philippines Co.

8th Floor, Anson's Centre,
#23 ADB Avenue,
Pasig City 1605,
Philippines
Tel: 632-7062609
Fax: 632-7062663
<http://www.epson.com.ph>

SINGAPORE

Epson Singapore Pte. Ltd.

1 HarbourFront Place,
#03-02 HarbourFront Tower 1,
Singapore 098633.
Tel: 6586 3111:
<http://www.epson.com.sg>

TAIWAN

Epson Taiwan Technology & Trading Ltd.

14F, No. 7, Song Ren Road,
Taipei, Taiwan.
Tel: (02) 8786-6688
Fax: (02) 8786-6633
<http://www.epson.com.tw>



THAILAND

Epson (Thailand) Co., Ltd.

195 Empire Tower, 42nd Floor,
South Sathorn Road,
Yannawa, Sathorn, Bangkok 10120,
Thailand

Tel: 02 685 9899

Fax: 02 685 9889

<http://www.epson.co.th>



Notices

General Specifications

Product name	ELPDC12	
Dimensions	Open (W × D × H): 270 × 331 × 476 mm (10.6 × 13.0 × 18.7 inches) Folded (W × D × H): 340 × 124 × 125 mm (13.4 × 4.9 × 4.9 inches)	
Type of sensor	1/2.7 inch CMOS sensor	
Lens	F=2	
Effective pixels	2 megapixel (1920 × 1080)	
Imaging area	1080p: 29.7 × 52.6 cm (11.7 × 20.7 inches)	
Focus adjustment	Automatic/manual	
Zoom adjustment	16x digital	
Frame rate	Up to 30 fps	
Internal memory	1GB	
Internal microphone	1 (monaural input)	
Power supply	AC adapter	100-240VAC ±10%, 50/60Hz
	ELPDC12	12VDC
Power consumption	Operating: 13 W Standby: 0.43W	
Operating temperature	+5 to +35°C (41 to 95°F), non-condensing	
Storage temperature	-10 to +60°C (14 to 140°F), non-condensing	
Operating humidity	20 to 80% RH, non-condensing	
Storage humidity	10 to 90% RH, non-condensing	
Weight	Approx. 2.8 kg (6.2 lb)	

Input port	Computer In port	1	Mini D-Sub15-pin (female)
	Mic In port	1	Stereo mini pin jack (monaural input)

Output port	Display Out port	1	Mini D-Sub15-pin (female) Output: SXGA/WXGA(1280x800)/WXGA(1360x768)/XGA/Full HD
	Composite port	1	RCA pin jack Output: NTSC/PAL
	HDMI port	1	HDMI Output: SDTV(480p)/HDTV(720p, 1080p)
Connector port	USB-A port*	1	USB connector (TypeA)
	USB-B port*	1	USB connector (TypeB) Output: QVGA/VGA/SVGA/SXGA/XGA
	SD card slot	1	SD/SDHC card compatible

* USB 2.0 is supported. However, the operation of all USB compatible devices is not guaranteed.

System Requirements

These system requirements are for using the included software:

Windows: Microsoft Windows 8 32/64-bit, Windows 7 32/64-bit, Windows Vista 32-bit, Windows XP (Service Pack 3 or later)

Mac OS X: Mac OS X 10.5 to 10.8

CPU: Pentium 4 1.4 GHz or higher (Windows XP)/Pentium 4 2.4 GHz or higher (Windows Vista/Windows 7)/PowerPC G5 1.8 GHz processor or Intel Core processor

Memory: 512 MB or more

Available hard disk space: 300 MB or more of available hard disk space is required before installation

Monitor: SVGA (800 x 600) or higher resolution

This product is also designed for IT power distribution system with phase-to-phase voltage 230V.

For United States Users

This equipment has been tested and found to comply with the limits for a Class B digital device, pursuant to Part 15 of the FCC Rules. These limits are designed to provide reasonable protection against harmful interference in a residential installation. This equipment generates, uses, and can radiate radio frequency energy and, if not installed and used in accordance with the instructions, may cause harmful interference to radio communications.

However, there is no guarantee that interference will not occur in a particular installation. If this equipment does cause interference to radio and television reception, which can be determined by turning the equipment off and on, the user is encouraged to try to correct the interference by one or more of the following measures:

- Reorient or relocate the receiving antenna.
- Increase the separation between the equipment and receiver.
- Connect the equipment into an outlet on a circuit different from that to which the receiver is connected.
- Consult the dealer or an experienced radio/TV technician for help.

WARNING

The connection of a non-shielded equipment interface cable to this equipment will invalidate the FCC Certification or Declaration of this device and may cause interference levels which exceed the limits established by the FCC for this equipment. It is the responsibility of the user to obtain and use a shielded equipment interface cable with this device. If this equipment has more than one interface connector, do not leave cables connected to unused interfaces. Changes or modifications not expressly approved by the manufacturer could void the user's authority to operate the equipment.

For Canadian Users

CAN ICES-3 (B) / NMB-3 (B)

According to 47CFR, Part 2 and 15 Class B Personal Computers and Peripherals; and/or CPU Boards and Power Supplies used with Class B Personal Computers

We: Epson America, Inc.
Located at: 3840 Kilroy Airport Way
MS: 3-13
Long Beach, CA 90806
Telephone: (562) 981-3840

Declare under sole responsibility that the product identified herein, complies with 47CFR Part 2 and 15 of the FCC rules as a Class B digital device. Each product marketed, is identical to the representative unit tested and found to be compliant with the standards. Records maintained continue to reflect the equipment being produced can be expected to be within the variation accepted, due to quantity production and testing on a statistical basis as required by 47CFR 2.909. Operation is subject to the following two conditions: (1) this device may not cause harmful interference, and (2) this device must accept any interference received, including interference that may cause undesired operation.

Trade Name: EPSON
Type of Product: Document camera
Model: ELPDC12

All rights reserved. No part of this publication may be reproduced, stored in a retrieval system, or transmitted in any form or by any means, electronic, mechanical, photocopying, recording, or otherwise, without the prior written permission of Seiko Epson Corporation. No patent liability is assumed with respect to the use of the information contained herein. Neither is any liability assumed for damages resulting from the use of the information contained herein.

Neither Seiko Epson Corporation nor its affiliates shall be liable to the purchaser of this product or third parties for damages, losses, costs, or expenses incurred by the purchaser or third parties as a result of: accident, misuse, or abuse of this product or unauthorized modifications, repairs, or alterations to this product, or (excluding the U.S.) failure to strictly comply with Seiko Epson Corporation's operating and maintenance instructions.

Seiko Epson Corporation shall not be liable against any damages or problems arising from the use of any options or any consumable products other than those designated as Original Epson Products or Epson Approved Products by Seiko Epson Corporation.

The contents of this guide may be changed or updated without further notice.

Illustrations in this guide and the actual projector may differ.

Microsoft, Windows, Windows NT, Windows Vista, PowerPoint, and Windows logo are trademarks or registered trademarks of Microsoft Corporation in the United States and/or other countries.

ArcSoft is a registered trademark of ArcSoft Company.

ArcSoft Application Software for Epson Document Camera © 2013 ArcSoft, Inc. All rights reserved.

YouTube is a trademark of Google Inc.



SDHC Logo is a trademark of SD-3C, LLC.

HDMI and High-Definition Multimedia Interface are the trademarks or registered trademarks of HDMI Licensing LLC. The HDMI logo, consisting of the letters "HDMI" in a bold, sans-serif font, with "HIGH DEFINITION MULTIMEDIA INTERFACE" written in smaller text below it.

General Notice: Other product names used herein are for identification purposes only and may be trademarks of their respective owners. Epson disclaims any and all rights in those marks.

This information is subject to change without notice.

© SEIKO EPSON CORPORATION 2013. All rights reserved.

Responsible Use of Copyrighted Materials

Epson encourages each user to be responsible and respectful of the copyright laws when using any Epson product. While some countries' laws permit limited copying or reuse of copyrighted material in certain circumstances, those circumstances may not be as broad as some people assume. Contact your legal advisor for any questions regarding copyright law.

Trademarks

Apple, Macintosh, and Mac OS are registered trademarks of Apple Inc.